

WHITNEY TOWERS AND GROPEs IN 4-MANIFOLDS

ROB SCHNEIDERMAN

ABSTRACT. Many open problems and important theorems in low-dimensional topology have been formulated as statements about certain 2-complexes called *grope*s. This paper describes a precise correspondence between embedded grope s in 4-manifolds and the failure of the Whitney move in terms of iterated ‘towers’ of Whitney disks. The ‘flexibility’ of these *Whitney towers* is used to demonstrate some geometric consequences for knot and link concordance connected to n -solvability, k -cobordism and grope concordance. The key observation is that the essential structure of grope s and Whitney towers can be described by embedded univalent trees which can be controlled during surgeries and Whitney moves. It is shown that a Whitney move in a Whitney tower induces an IHX (Jacobi) relation on the embedded trees.

1. INTRODUCTION

Many open problems and important theorems in low-dimensional topology, including the classification theory of topological 4-dimensional manifolds and the study of knots and links in 3-manifolds, have been formulated in terms of statements about smooth maps of certain 2-complexes called *grope*s. As suggested by its name, a grope is built inductively from layers of surfaces which “reach into” a 4-manifold in an attempt to approximate an embedded 2-disk (see [24]). The existence of generically embedded 2-disks in dimensions greater than 4 allows for use of the Whitney move, a vital part of the surgery programs which yield classification theorems for higher-dimensional manifolds and knotted submanifolds. The failure in general of the Whitney move in dimension 4 is a defining characteristic of low-dimensional topology, and this paper describes a precise correspondence between grope s and an approximation to the Whitney move via certain “towers” of iterated Whitney disks.

A Whitney move eliminates a pair of singularities between immersed surfaces in a 4-manifold but will also create new intersections if the guiding Whitney disk contains singularities in its interior. A *Whitney tower* is constructed by pairing such singularities in the interiors of Whitney disks with “higher order” Whitney disks in an attempt to find embedded Whitney disks via “higher order” Whitney moves (Figure 1 and Section 3).

Received by the editors March 7, 2004 and, in revised form, May 25, 2004.

2000 *Mathematics Subject Classification*. Primary 57M99; Secondary 57M25.

Key words and phrases. Whitney tower, grope, 4-manifold, Whitney move, n -solvability, k -cobordism, grope concordance, IHX relation.

The author is an NSF VIGRE postdoctoral fellow at the Courant Institute of Mathematical Sciences.

©2005 American Mathematical Society
Reverts to public domain 28 years from publication

The *order* of a Whitney tower (Definition 3.1) is determined by the number of layers of Whitney disks added to the immersed surfaces and the *class* of a grope (Figure 2 and Definition 2.1) measures its complexity in terms of the number of its layers or *stages* of surfaces.

In the case of gropes, all singularities are usually contained in *caps* which are 2–disks that are mapped in after all stages of embedded surfaces have been attached. The caps are attached along essential curves called *tips* (details in Section 2).

The correspondence between class and order is described by the following basic version of our main result:

Theorem 1. *For any collection of embedded closed curves γ_i in the boundary of a 4–manifold X , the following are equivalent:*

- (i) *The γ_i bound disjoint properly embedded class n gropes g_i with null-homotopic tips in X .*
- (ii) *The γ_i bound properly immersed 2–disks D_i admitting an order $(n - 1)$ Whitney tower \mathcal{W} in X .*

The proof of Theorem 1 is given by a local construction, meaning that, given caps for the g_i , the D_i and \mathcal{W} are constructed in a neighborhood of the capped gropes g_i^c and, given the D_i contained in \mathcal{W} , the gropes g_i (and caps) are constructed in a neighborhood of \mathcal{W} . (This construction also applies to *closed* (boundaryless) gropes and Whitney towers.)

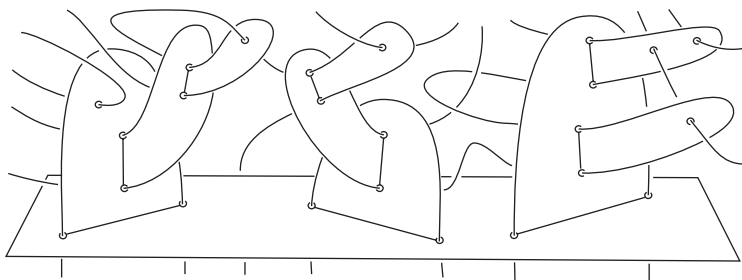

FIGURE 1. Part of a Whitney tower.

Univalent trees. In fact, a much more precise and more general correspondence between gropes and Whitney towers can be described in terms of univalent trees (Sections 2.3, 3.5) which capture the essential structure of both gropes and Whitney towers. This correspondence is given in Theorem 5 and Theorem 6, which are stated and proved in Section 5 (and directly imply Theorem 1). The key element used in the proofs of these theorems and their corollaries is that the associated trees, embedded as subsets of the gropes and Whitney towers, can be preserved and controlled during modifications such as ambient surgery or Whitney moves.

Remark 1.1. Besides providing an interpretation of gropes in terms of Whitney disks, the notion of Whitney towers comes equipped with an obstruction theory that generalizes the usual intersection theory for surfaces in 4–manifolds. The associated invariants τ_n take values in graded groups of trees which generalize the well-known target groups of finite type concordance invariants of links. These higher

order intersection trees are enhancements of the trees discussed in this paper and are used in [21] to give a geometric description of Milnor's μ -invariants and the (reduced) Kontsevich integral for links, and are also used in [22] to obtain results on separating homotopy classes of surfaces in 4-manifolds.

Symmetric gropes and n -solvability. It should be noted that the Whitney towers described here differ from the towers that appear in the theory of Casson handles ([9], [18]) in that the latter always involve killing the so-called "accessory circles" that run through the singularities. The gropes that arise in the context of Casson handles are certain capped *symmetric* gropes whose singularities are restricted to intersections among the caps ([10]).

The notion of Whitney tower described here *is* related to general symmetric gropes (without restrictions on caps) and the recently discovered filtration of the classical knot concordance group in terms of *n -solvability* by Cochran, Orr and Teichner [5]: A Whitney tower of *height n* (resp. *$n.5$*) as defined in [5] is a Whitney tower of order $2^n - 2$ (resp. $2^n + 2^{(n-1)} - 2$) with certain additional restrictions on the type of allowable intersections (see Section 6). This definition of height is in rough correspondence with the usual definition of height for a symmetric (uncapped) grope, and in [5] it is shown that a knot in the 3-sphere $S^3 = \partial B^4$ is n -solvable if it bounds an embedded symmetric grope of height $n + 2$ or a Whitney tower of height $n + 2$ in B^4 . It is not known if these geometric conditions are equivalent to each other (or to being n -solvable) but we do have:

Corollary 2. *If a knot in S^3 bounds a properly embedded grope of height n (resp. $n.5$) in B^4 , then the knot bounds a Whitney tower of height n (resp. $n.5$) in B^4 .*

The proof of Corollary 2 suggests that bounding a grope of height n is probably a stronger condition than bounding a Whitney tower of height n (see Section 6).

Half-gropes, k -cobordism and geometric IHX. In the general study of knot and link concordance (cobordism) the translation between gropes and Whitney towers can be helpful in understanding connections between algebraically and geometrically defined filtrations. This is the case in the next two corollaries which are proved by applying a geometric "IHX" Jacobi relation to manipulate the trees associated to a Whitney tower (Lemma 7.2).

In analogy with the fact that the n th term of the lower central series of a group is generated by *simple* (right- or left-normed) commutators ([16]), we have the following geometric result which implies in particular that class n *grope concordance* is generated by class n (annulus-like) *half-gropes* (details in Section 7):

Corollary 3. *If γ_i bound disjoint properly embedded A_i -like class n gropes g_i with null-homotopic tips in a 4-manifold X , then the γ_i bound disjoint properly embedded A_i -like class n half-gropes h_i with null-homotopic tips in X , with the h_i^c contained in a neighborhood of g_i^c for any choice of caps on the g_i .*

Since a symmetric grope of height n has class 2^n , Corollary 3 also gives a geometric (embedded) analogue of the fact that the n th derived subgroup is contained in the 2^n th lower central subgroup of a group.

In the case of knots in S^3 , it was shown constructively in [19] (see also [8]) that the Arf invariant is the only obstruction to the existence of a (half)-grope concordance

of arbitrarily high class. Thus, the Von Neumann signatures of [5] which obstruct n -solvability are obstructions to “inverting” the geometric manipulations of gropes and Whitney towers via geometric IHX constructions (as used, for instance, in the proof of Corollary 3 above) to convert class into height.

The filtration of link concordance classes by the notion of k -cobordism was introduced and studied in [2], [3], [4] and [17]. In particular, a link L in S^3 is k -slice (k -null-cobordant) if the link components bound disjoint surfaces in B^4 which “look (algebraically) like” slice disks modulo the k th term of the lower central series of the link group $\pi_1(S^3 - L)$. This was shown in [12] to be equivalent to L having vanishing Milnor $\bar{\mu}$ -invariants up through length $2k$. The precise relation between grope concordance and Milnor’s invariants is not known, however class n grope concordance implies length n Milnor–equivalence ([15]). Evidence that class n grope concordance is *stronger* than length n Milnor–equivalence is provided by the easy proof of the following corollary, in contrast to the difficulties encountered in the just mentioned result in [12].

Corollary 4. *If the components of a link L in S^3 bound disjoint properly embedded class $2k$ gropes in the B^4 , then L is k -slice.*

The proof of Corollary 4 uses the flexibility of Whitney towers to “evenly distribute” the gropes’ higher surface stages over symplectic sets of circles on the bottom surfaces. In fact, the proof yields a stronger conclusion as described in Section 8. (The same proof also shows more generally that class $2k$ grope concordance implies k -cobordism.)

Further applications. Although closely related, Whitney towers are slightly more general objects than gropes as is suggested by the association of *rooted* trees to gropes and *unrooted* trees to Whitney towers. This generality is conducive to defining geometric invariants associated to an obstruction theory (as mentioned in Remark 1.1) as well as manipulating the shape of gropes (as in Corollaries 3 and 4 above). However, in certain constructions it is useful to convert Whitney towers into gropes, for instance to take advantage of nice properties of embedded grope complements. This interplay is exploited in [23] which describes the geometry of Milnor’s μ -invariants in terms of Whitney towers and grope concordance. Recent work of Conant and Teichner ([7], [8]) suggests that the study of both 3- and 4-dimensional grope cobordism of restricted graph type can play an important role in the general theory of knots and links. The relevant graphs in 4-dimensions are the univalent trees which occur here naturally in the context of Whitney towers. Perhaps an analogous notion of a Whitney tower projected into 3 dimensions with associated univalent graphs could be useful in understanding 3-dimensional grope cobordism.

Outline. Gropes are discussed in Section 2. Section 3 covers Whitney towers, including two lemmas (3.5 and 3.6) which are used in subsequent constructions. Section 4 introduces the hybrid (*split*) *grope subtowers* which are used to interpolate between gropes and Whitney towers. Theorem 1 is then proved via the more detailed Theorem 5 and Theorem 6 which are stated and proved in Section 5. A proof of Corollary 2 is given in Section 6. A proof of Corollary 3 is given in Section 7, which also contains a geometric (IHX) construction (Lemma 7.2) which is used in [21]. A proof of Corollary 4 is given in Section 8.

Conventions. All maps and manifolds are assumed smooth and oriented. Surfaces in 4-manifolds are illustrated in figures showing a 3-dimensional slice of local 4-dimensional coordinates with the understanding that sheets of surfaces that appear as 1-dimensional arcs in the “present” 3-dimensional slice extend as a product into the “past and future” coordinate. Sheets of surfaces which are contained in the 3-dimensional slice may appear either translucent or opaque.

2. GROPEs

This section contains mostly standard grope terminology for the purpose of fixing notation since there are subtle differences in definitions and approaches throughout the literature. See any of [10], [11] or [15] for detailed discussions of grope in 4-manifolds.

There will be, however, a few mildly non-standard wrinkles which are worth pointing out: It will be convenient to consider the punctured *starting surface* A^0 of an A -like grope g as a 0 th stage of g , and it will be helpful think of g as formed from A^0 by attaching many genus one grope rather than a single higher genus grope. In light of these notational conventions, it turns out to be convenient to associate to each grope a disjoint union of univalent trees (as in [6], [7] and [8]) rather than the customary (single) multivalent tree (e.g. in [15]). This point of view is in line with Krushkal’s grope-splitting technique [13] which simplifies the combinatorics of grope. Note also that what we will refer to as a *dyadic* grope is called a “grope with dyadic branches” in [14].

2.1. Grope terminology.

Definition 2.1 ([11]). A *grope* is a special pair (2-complex, circle). A grope has a *class* $n \in \{1, 2, \dots, \infty\}$. A class 1 grope is defined to be the pair (circle, circle). A class 2 grope $(S, \partial S)$ is a compact oriented connected surface S with a single boundary component. For $n > 2$, a grope of class n is defined inductively as follows: Let $\{\alpha_j, \beta_j, j = 1, \dots, \text{genus}\}$ be a chosen standard symplectic basis of circles for a class 2 grope S . For any positive integers a_j, b_j , with $a_i + b_j \geq n$ and $a_{j_0} + b_{j_0} = n$ for at least one index j_0 , a grope of class n is formed by attaching a class a_j grope to each α_j and a class b_j grope to each β_j (see Figure 2).

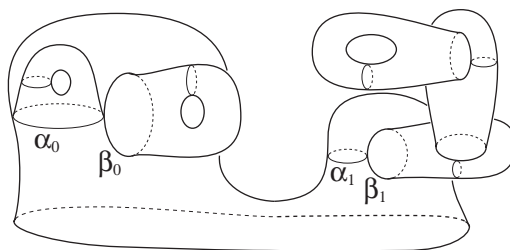

FIGURE 2. A grope of class 4 (see Definition 2.1).

Here “attaching a class 1 grope” is understood to mean “not attaching a grope at all”. The surfaces in a grope g are called *stages* and the basis circles in (all stages of) g which do not have a surface stage attached to them are the *tips* of g .

Attaching 2–disks, called *caps*, to all the tips of g yields a *capped grope* g^c , and the underlying uncapped grope g is the *body* of g^c .

It is customary to omit the boundary of a grope from notation. We adopt the convention that the *tip* of a class 1 grope is the grope (a circle) itself, so a class one capped grope is just a circle bounding a disk.

Note that a class n grope is *not* really also a grope of class m for $m < n$, but can always be made into one by deleting some surface stages (in order to satisfy $a_{j_0} + b_{j_0} = m$ for at least one index j_0).

2.2. Dyadic A –like gropes with 0th stages. The gropes of Definition 2.1 are special cases of the more general A –like (capped) grope of class n which is gotten from a starting surface A by replacing disks in A with (capped) gropes of class n as defined above. All the notions such as stages, tips and caps apply to A –like gropes without change with the following addition: If g is an A –like grope, then the *0th stage* of g is defined to be the punctured surface A^0 which is A minus the disks that were replaced by gropes to form g . The 0th stage is included in the body of an A –like capped grope. In this language, the gropes of Definition 2.1 can be thought of as disk-like gropes.

An A –like (capped) grope g is *dyadic* if all surface stages of all gropes attached to the 0th stage A^0 are genus one surfaces (see Figure 3). Since we are allowing A^0 to have many punctures, any (capped) A –like grope can be converted to a (capped) dyadic A –like grope by Krushkal’s grope-splitting technique [13].

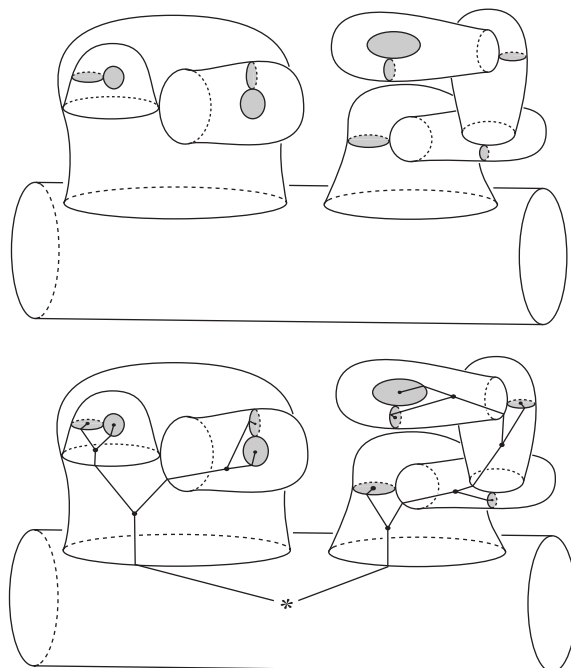

FIGURE 3. A dyadic annulus-like capped grope g^c of class 4, also shown with the embedding of $t(g^c)$ in g^c . The 0th stage of g^c is the twice-punctured annulus.

The notion of dyadic gropes was introduced in [14]; our terminology is slightly different in that instead of allowing higher genus in the first stage we attach many genus 1 gropes to the 0th stage. Also, for brevity we are using the term “dyadic grope” here instead of (the more precise) “grope with dyadic branches” as in [14].

2.3. Rooted trees for gropes. A *tree* is a connected graph without 1-cycles. A *rooted tree* has a single preferred univalent vertex called the *root*. To each A -like dyadic capped grope g^c , we associate a disjoint union $t(g^c)$ of rooted univalent trees which is essentially the dual one-complex: The vertices of $t(g^c)$ are (dual to) the stages and caps of g^c , with two vertices joined by an edge if the corresponding stages/caps meet in a circle. The univalent vertices corresponding to the 0th stages are the roots.

It will be helpful to think of $t(g^c)$ as being embedded in g^c in the following way. Choose a basepoint in each stage (including A^0) and a basepoint in each cap of g^c . If g^c was formed by removing just one disk from A , then connecting basepoints in adjacent stages and caps by sheet-changing paths yields an embedded connected univalent tree; here “adjacent” means “intersecting along a circle” so that dual stages/caps (having a single intersection point in their boundaries) are not considered to be adjacent. If g^c was formed by replacing m disks of A , then we get m univalent trees (each “sprouting from” the basepoint in the 0th stage A^0), and $t(g^c)$ is the disjoint union of these m trees (Figure 3). Each trivalent vertex of $t(g^c)$ corresponds to a genus one stage in g^c and each univalent vertex of $t(g^c)$ corresponds to a cap of g^c , except for one univalent vertex on each connected component of $t(g^c)$ which corresponds to A^0 . These univalent vertices on the A^0 are the root vertices of $t(g^c)$. To the underlying uncapped grope g is associated the same disjoint union of rooted trees denoted $t(g)$.

Following the terminology of [21], define the *order* of a univalent tree to be the number of trivalent vertices. Note that the class of g^c is equal to one more than the minimum of the orders of the trees in $t(g^c)$.

The reader familiar with previous associations of multi-valent trees to arbitrary A -like gropes (e.g. [15]) can check that our definition of $t(g^c)$ is essentially what you would get after applying Krushkal’s grope-splitting procedure. In fact, a formal sum of *vertex-oriented* trees can be associated to an *oriented* grope ([6] [7] [8]); although we will not work with orientations in this paper, the notation here has been chosen to be compatible with the just cited works.

2.4. Proper immersions of gropes. A surface is *properly* immersed in a 4-manifold if boundary is embedded in boundary and interior is immersed in interior. Immersions of (capped) gropes into a 4-manifold are required to factor through an embedding in 3-space followed by standard product thickenings and plumbings, so that a regular neighborhood of the immersion contains disjoint parallel copies of any embedded subsets of the (capped) grope. An immersion of (capped) gropes is *proper* if the bottom stage surfaces are properly immersed and all other stages (and caps) are immersed in the interior.

In much of the literature, a proper immersion of a capped grope in a 4-manifold will have restrictions on allowable grope/cap singularities. We will not make such restrictions, however it will be convenient to arrange for all intersections to occur among 0th stages and between caps and 0th stages.

3. WHITNEY TOWERS

After defining *Whitney towers*, the main goal of this section is to show how the essential geometric structure of a Whitney tower \mathcal{W} is captured by a disjoint union $t(\mathcal{W})$ of univalent (labelled) trees. The surfaces of \mathcal{W} are indexed by brackets which correspond to rooted trees, and each intersection point p of \mathcal{W} is then assigned an unrooted tree $t(p)$ which is a pairing of the rooted trees that correspond to the intersecting surfaces. After introducing the notion of (*split*) *subtowers*, Lemma 3.5 then shows how \mathcal{W} can be decomposed into essential parts which are described by the disjoint union $t(\mathcal{W})$ of all the $t(p)$. Finally, Lemma 3.6, which will play a key role in later proofs, gives further evidence of the essential nature of $t(\mathcal{W})$ by showing how the trees $t(p)$ are “stable” under certain Whitney moves.

All of the material in this section can be enhanced to take into account orientations as well as the fundamental group of the ambient manifold by adding vertex-orientations and edge-decorations to the trees. Such enhancements are used in the obstruction theory of [20], [21], [22], and [23]. Notation in this paper has been chosen to be consistent with these papers where they overlap.

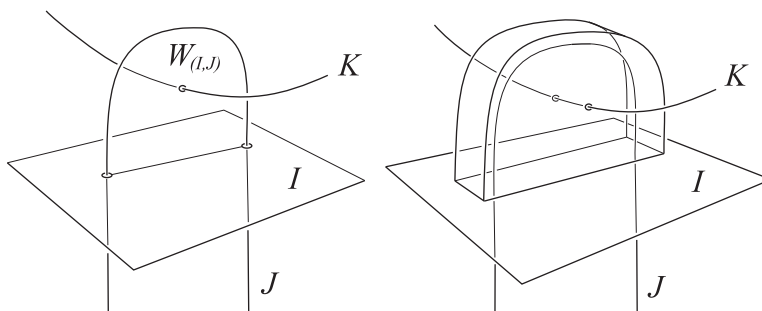

FIGURE 4. The embedded Whitney disk $W_{(I,J)}$ guides a Whitney move that eliminates a cancelling pair of intersections between surface sheets I and J via an isotopy of I . Since $W_{(I,J)}$ had an interior intersection with a surface sheet K , this Whitney move creates a new cancelling pair of intersections between I and K .

3.1. Whitney disks. We refer the reader to [10] for a detailed description of the *Whitney move* in dimension 4. For our purposes it is enough to understand the model Whitney move on an embedded Whitney disk in 4-space as illustrated in Figure 4, which shows the effect of a Whitney move on three local sheets of surfaces: The Whitney move is guided by an embedded *Whitney disk* labelled $W_{(I,J)}$ which *pairs* a (geometrically) *cancelling pair* of intersection points between sheets of surfaces labelled I and J . In Figure 4, the I -sheet is locally contained in the 3-dimensional “present” and the J - and K -sheets extend into “past and future”. The Whitney move eliminates the cancelling pair of intersections between I and J by an isotopy of I across $W_{(I,J)}$ at the cost of introducing a new cancelling pair of intersection points between I and the sheet labelled K which intersected the interior of the guiding Whitney disk $W_{(I,J)}$.

3.2. Whitney towers. In general, a Whitney disk may have multiple interior self-intersections and intersections with other surface sheets; however we will require that arbitrary Whitney disks resemble the model near their boundaries. By pairing up interior intersections with higher order Whitney disks we are led to the notion of a Whitney tower:

Definition 3.1.

- A *surface of order 0* in a 4-manifold X is a properly immersed surface (boundary embedded in the boundary of X and interior immersed in the interior of X). A *Whitney tower of order 0* in X is a collection of order 0 surfaces.
- The *order of a (transverse) intersection point* between a surface of order n and a surface of order m is $n + m$.
- The *order of a Whitney disk* is $(n + 1)$ if it pairs intersection points of order n .
- For $n \geq 0$, a *Whitney tower of order $(n + 1)$* is a Whitney tower \mathcal{W} of order n together with Whitney disks pairing all order n intersection points of \mathcal{W} . The interiors of these top order disks are allowed to intersect each other as well as lower order surfaces.

The Whitney disks in a Whitney tower are required to be *framed* (see [10]) and have disjointly embedded boundaries. It will also be assumed that the order 0 surfaces are *0-framed* (see 1.2 of [10]).

Thus, in an order n Whitney tower all intersection points of order less than n occur in cancelling pairs with respect to (arbitrarily) chosen orientations of all Whitney disks (see Figure 1). Note that the boundary of any Whitney disk is not allowed to change sheets except at the intersection points paired by the Whitney disk.

Some further terminology: If \mathcal{W}_0 is an order 0 Whitney tower and there exists an order n Whitney tower \mathcal{W}_n containing \mathcal{W}_0 as its order 0 surfaces, then \mathcal{W}_0 is said to *admit* an order n Whitney tower, and any one of the order 0 surfaces in \mathcal{W}_n is said to *support* the n th order Whitney tower \mathcal{W}_n .

3.3. Rooted trees and brackets. Non-associative but commutative (unordered) *bracketings* of elements from some index set correspond to rooted labelled (unoriented) univalent trees as follows. A bracketing (i) of a singleton element i from the index set corresponds to the rooted *chord* $t(i)$ having a single edge with one vertex labelled by i and the other vertex designated as the root. A bracketing (I, J) of brackets I and J corresponds to the *rooted product* $t(I) * t(J)$ of the trees $t(I)$ and $t(J)$ which identifies together the roots of $t(I)$ and $t(J)$ to a single vertex and “sprouts” a new rooted edge at this vertex (Figure 5). Thus, the (non-root) univalent vertices of the tree $t(I)$ associated to a bracket I are labelled by elements from the index set and the trivalent vertices correspond to sub-bracketings of I , with the trivalent vertex adjacent to the root corresponding to I .

3.4. Rooted trees for Whitney disks. The rooted trees and bracketings of the previous subsection are associated to the surfaces in a Whitney tower \mathcal{W} both formally and geometrically as follows: A bracketing (i) of a singleton element i from the index set is associated to each order zero surface. The bracket (I, J) is associated to a Whitney disk pairing intersections between surfaces with associated

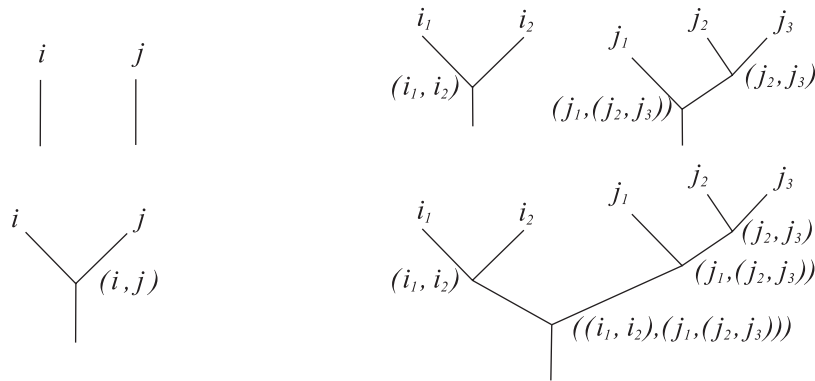

FIGURE 5. Rooted trees and brackets: $t(i)$ and $t(j)$ (upper left) and their rooted product $t(i, j) = t(i) * t(j)$ (lower left); $t(i_1, i_2)$ and $t(j_1, (j_2, j_3))$ (upper right) and their rooted product $t((i_1, i_2), (j_1, (j_2, j_3))) = t(i_1, i_2) * t(j_1, (j_2, j_3))$ (lower right).

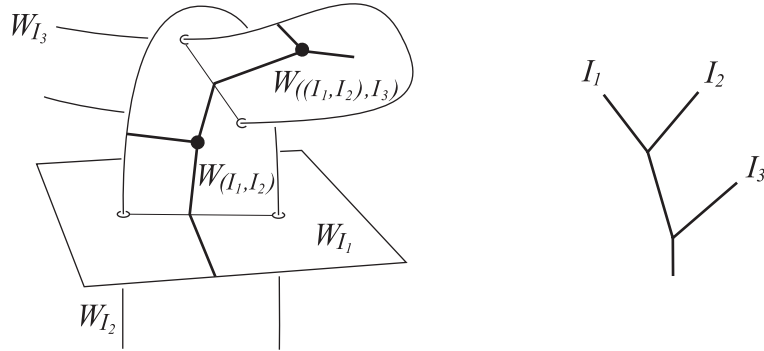

FIGURE 6. A Whitney disk $W_{((I_1, I_2), I_3)}$ and (part of) its associated tree $t(W_{((I_1, I_2), I_3)})$ shown both as a subset of the Whitney tower and as an abstract rooted tree. (If any I_i is not a singleton, then that label I_i represents a sub-tree.)

brackets I and J . Using brackets as subscripts, we write A_i for an order zero surface (dropping the brackets around the singleton i) and $W_{(i, j)}$ for a first order Whitney disk that pairs intersections between A_i and A_j . In general, we write $W_{(I, J)}$ for a Whitney disk pairing intersections between W_I and W_J , with the understanding that if a bracket I is just a singleton (i), then the surface $W_I = W_{(i)}$ is just the order zero surface A_i . The rooted labelled tree $t(W_I)$ associated to W_I is defined to be $t(I)$, the tree that corresponds to the bracket I as before (Section 3.3). Note that the order of W_I is equal to the order of $t(W_I)$ (i.e. the number of trivalent vertices).

In fact, the tree $t(W_I)$ can be mapped into \mathcal{W} in a similar fashion to the case of grope (Section 2.3): First fix a basepoint in the interior of each surface (including the Whitney disks) of \mathcal{W} . (If an order zero surface is not connected, put a basepoint in each component.) Now map the vertices (other than the root) of $t(W_I)$ to the basepoints of the surfaces corresponding to the sub-brackets of I and map the edges (other than the edge adjacent to the root) of $t(W_I)$ to sheet-changing paths between these basepoints, as illustrated in Figure 6. Then embed the root and its edge anywhere in the interior of W_I .

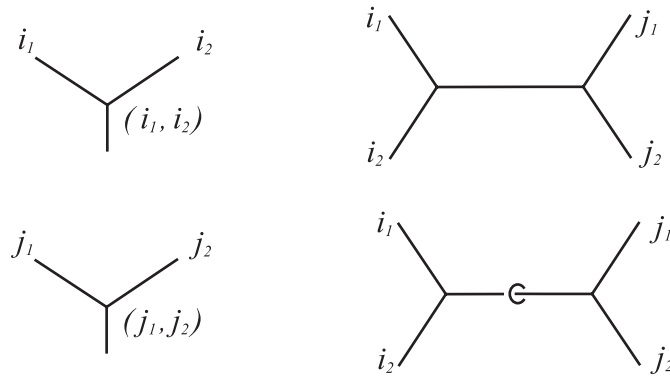

FIGURE 7. On the left, a pair of rooted trees $t(I)$ and $t(J)$ corresponding to first order Whitney disks W_I and W_J with $I = (i_1, i_2)$ and $J = (j_1, j_2)$. On the upper right, the inner product $t(p) = t(I) \cdot t(J)$ associated to a 2nd order intersection point $p \in W_I \cap W_J$ and on the lower right, the punctured tree $t^\circ(p)$ that also keeps track of p .

3.5. Trees for intersection points. Given a pair $t(I)$ and $t(J)$ of rooted trees, define the *inner product* $t(I) \cdot t(J)$ to be the labelled *unrooted* tree gotten by identifying together the root vertices of $t(I)$ and $t(J)$ to a single (non-vertex) point. The tree $t(p)$ associated to a (transverse) intersection point $p \in W_I \cap W_J$ between surfaces W_I and W_J in a Whitney tower \mathcal{W} is defined to be the inner product $t(W_I) \cdot t(W_J)$ ($= t(I) \cdot t(J)$) of the rooted trees corresponding to W_I and W_J as illustrated in Figure 7. Note that the order of p is equal to the order of $t(p)$.

The above-mentioned mappings of $t(W_I)$ and $t(W_J)$ in \mathcal{W} give rise to a mapping of $t(p)$ into \mathcal{W} : Just map the root vertices of W_I and W_J to p and the adjacent edges become a path between the basepoints of W_I and W_J which changes sheets at p (Figure 8). This mapping can be taken to be an embedding of $t(p)$ into \mathcal{W} if all the Whitney disks “beneath” W_I and W_J (corresponding to sub-brackets of I and J) are distinct.

It is sometimes convenient to keep track of the edge of $t(p)$ that corresponds to p by marking that edge with a small linking circle as in Figure 7 and Figure 8; such a *punctured tree* will be denoted by $t^\circ(p)$.

3.6. Trees for Whitney towers. For any Whitney tower \mathcal{W} define $t(\mathcal{W})$ to be the disjoint union of all the trees $t(p)$ for all unpaired intersection points $p \in T$.

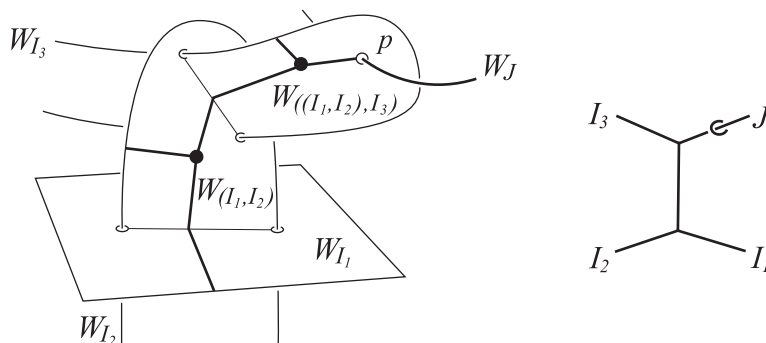

FIGURE 8. A local picture of the punctured tree $t^\circ(p)$ associated to an intersection point $p \in W_I \cap W_J$, shown as a subset of the Whitney tower and as an abstract labelled (punctured) tree.

Remark 3.2. As mentioned at the start of this section, $t(\mathcal{W})$ can be enhanced with vertex-orientations and edge-decorations and is called the *geometric intersection tree* of \mathcal{W} . The invariants τ_n associated to the obstruction theory mentioned in Remark 1.1 are determined by such trees (e.g. [21]).

3.7. Split subtowers. In order to simplify constructions and combinatorics it will be helpful to “split” a Whitney tower into *split subtowers* analogous to Krushkal’s grope splitting procedure [13] which splits a grope into genus one “branches” (higher stages).

Definition 3.3. A *subtower* is a Whitney tower except that the boundaries of the immersed order zero surfaces in a subtower are allowed to lie in the interior of the 4–manifold. (The boundaries of the order zero surfaces in a subtower are still required to be embedded.) The notions of *order* for intersection points and Whitney disks are the same as in Definition 3.1.

Definition 3.4. A subtower \mathcal{W}_p is *split* if it satisfies all of the following:

- (i) \mathcal{W}_p contains a single unpaired intersection point p ,
- (ii) the order zero surfaces of \mathcal{W}_p are all embedded 2–disks,
- (iii) the Whitney disks of \mathcal{W}_p are all embedded,
- (iv) the interior of any surface in \mathcal{W}_p either contains p or contains a single Whitney arc of a Whitney disk in \mathcal{W}_p ,
- (v) \mathcal{W}_p is connected (as a 2–complex in the 4–manifold).

The tree $t(\mathcal{W}_p)$ associated to such a split subtower \mathcal{W}_p is just the tree $t(p)$ determined by its unpaired intersection point p (Section 3.5).

Note that the order of a split subtower \mathcal{W}_p is equal to the order of p and that a normal thickening of \mathcal{W}_p in the ambient 4–manifold is just a 4–ball neighborhood of the embedded tree $t(\mathcal{W}_p) = t(p)$.

3.8. Split Whitney towers and their trees.

Lemma 3.5. *Let \mathcal{W} be a Whitney tower on order 0 surfaces A_i . Then, for any regular neighborhood $N(\mathcal{W})$ of \mathcal{W} , there exists a Whitney tower $\mathcal{W}_{\text{split}}$ contained in*

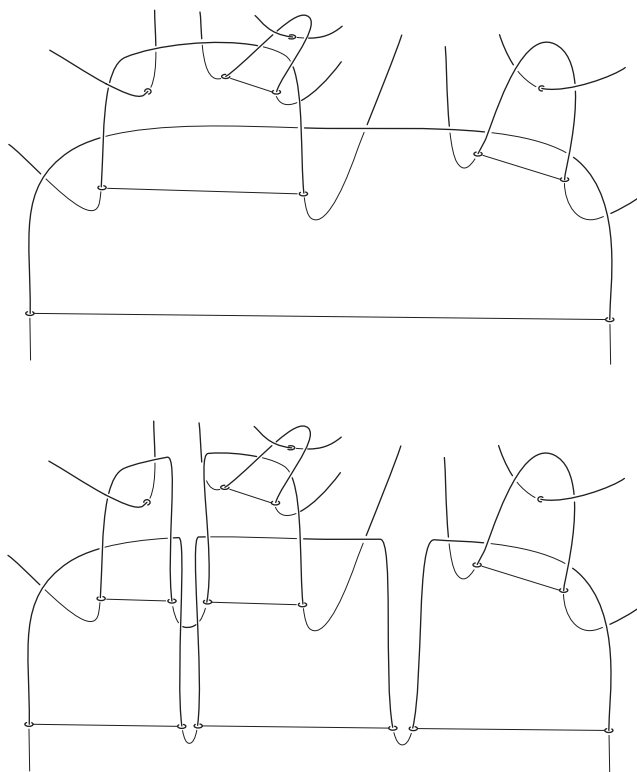

FIGURE 9. Part of a Whitney tower before (top) and after (bottom) applying the splitting procedure described in the proof of Lemma 3.5.

$N(\mathcal{W})$ such that:

- (i) The order 0 surfaces A'_i of $\mathcal{W}_{\text{split}}$ only differ from the A_i by finger moves.
- (ii) All unpaired intersection points of $\mathcal{W}_{\text{split}}$ are contained in disjoint split subtowers on sheets of the A'_i .
- (iii) $t(\mathcal{W})$ and $t(\mathcal{W}_{\text{split}})$ are isomorphic.

Such a Whitney tower $\mathcal{W}_{\text{split}}$ will be called a *split* Whitney tower. The disjoint union of trees $t(\mathcal{W}_{\text{split}})$ (Section 3.6) associated to $\mathcal{W}_{\text{split}}$ is the disjoint union of the trees $t(\mathcal{W}_p)$ associated to the split subtowers in $\mathcal{W}_{\text{split}}$. Also, $t(\mathcal{W}_{\text{split}})$ sits as an *embedded* subset of $\mathcal{W}_{\text{split}}$ via the description in Section 3.5.

Proof. Starting with the highest order Whitney disks of \mathcal{W} , apply finger moves as indicated in Figure 9. Working down through the lower order Whitney disks yields the desired $\mathcal{W}_{\text{split}}$. □

This decomposition of a Whitney tower into split subtowers corresponds to the idea that the disjoint union of trees associated to the Whitney tower captures its essential structure. The next lemma can be interpreted as justifying that this essential structure is indeed captured by the *unpunctured* trees rather than the punctured trees, in the sense that a punctured edge (corresponding to an unpaired intersection point) can be “moved” to any other edge of its tree.

Lemma 3.6. *Let \mathcal{W} be a split subtower on order zero sheets s_i , with unpaired intersection point $p = W_I \cap W_J \subset T$. Denote by $\nu(\mathcal{W})$ a normal thickening of \mathcal{W} , so that $\partial s_i \subset \partial \nu(\mathcal{W}) \subset \nu(\mathcal{W}) \cong B^4$. If I' and J' are any brackets such that $t(I') \cdot t(J') = t(p) = t(I) \cdot t(J)$, then after a homotopy (rel ∂) of the s_i in $\nu(\mathcal{W})$ the s_i admit a split subtower $\mathcal{W}' \subset \nu(\mathcal{W})$ with single unpaired intersection point $p' = W_{I'} \cap W_{J'} \subset T'$.*

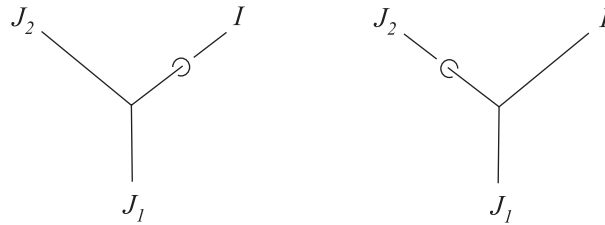

FIGURE 10. A local picture of the tree associated to the split subtower \mathcal{W} before (left) and \mathcal{W}' after (right) the Whitney move illustrated in Figure 11.

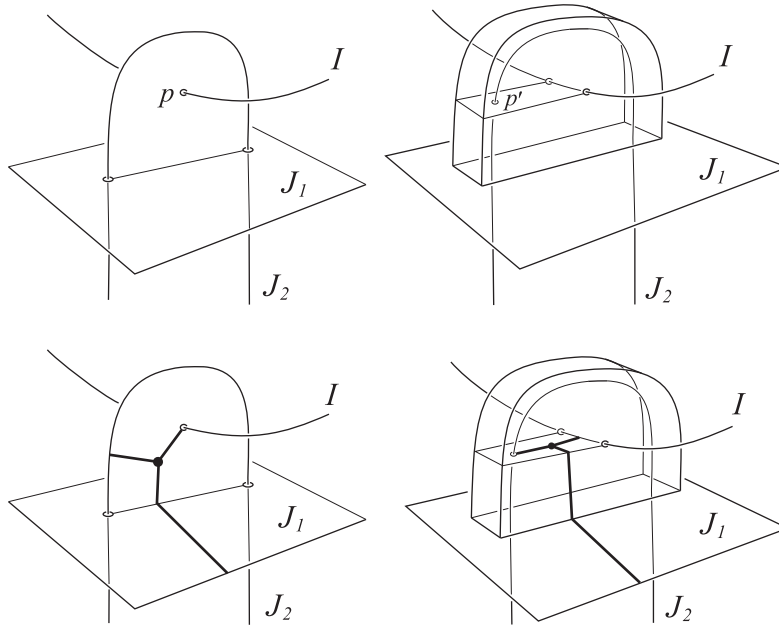

FIGURE 11. Upper left, the unpaired intersection point $p = W_I \cap W_J$ in the split subtower \mathcal{W} of Lemma 3.6. Upper right, the unpaired intersection point $p' = W_{I'} \cap W_{J'}$ in \mathcal{W}' after the Whitney move. The lower part of the figure shows that the punctured trees differ as indicated in Figure 10.

Proof. It is enough to show that the puncture in $t^\circ(p)$ can be “moved” to either *adjacent* edge, since by iterating it can be moved to any edge of $t(p)$. Specifically, it is enough to consider the case where $J = (J_1, J_2)$, $I' = (I, J_1)$ and $J' = J_2$ so that $I \cdot (J_1, J_2) = (I, J_1) \cdot J_2$ as in Figure 10. (Here we are assuming that W_J is not order zero, since if both W_I and W_J are order zero there is nothing to prove.) The proof is given by the maneuver illustrated in the upper part of Figure 11: Use the Whitney disk W_J to guide a Whitney move on W_{J_1} . This eliminates the intersections between W_{J_1} and W_{J_2} (as well as eliminating W_J and p) at the cost of creating a new cancelling pair of intersections between W_{J_1} and W_I . This new cancelling pair can be paired by a Whitney disk $W_{(I, J_1)}$ having a single intersection point p' with W_{J_2} . That this achieves the desired effect on the punctured tree is clear from the lower part of Figure 11. \square

4. GROPE SUBTOWERS

In this section a hybrid grope–Whitney tower combination is introduced, which will be used to interpolate between gropes and Whitney towers in the proofs of the next section: A *split grope subtower* is a collection of capped gropes whose caps support certain split subtowers. We assume from now on that all gropes are dyadic (Section 2.2).

The content of this section can essentially be grasped by inspecting Figure 12 and Figure 13, which illustrate split grope subtowers and their trees, and observing that the limiting cases reduce to gropes (Section 4.3) and Whitney towers (Section 4.4) respectively.

4.1. Split grope subtowers.

Definition 4.1. Let g_i^c be a collection of (dyadic) A_i –like capped gropes properly immersed in a 4–manifold such that:

- (i) The higher (greater than zero) stages of the g_i are all disjointly embedded and disjoint from the interiors of all caps,
- (ii) the interiors of all caps are disjointly embedded,
- (iii) each cap c supports a split subtower \mathcal{W}_c whose other order 0 surfaces are sheets of the 0th stage surfaces A_i^0 ,
- (iv) the \mathcal{W}_c are disjoint and contain all singularities among the 0th stages A_i^0 .

Denote by $g_i^{\mathcal{W}}$ the union of the grope g_i^c and the subtowers on its caps. The union $g^{\mathcal{W}}$ of all the $g_i^{\mathcal{W}}$ is a *split grope subtower* (see Figure 12). The *class* of $g_i^{\mathcal{W}}$ is the class of the underlying grope g_i^c . The *class* of $g^{\mathcal{W}}$ is the minimum of the classes of the $g_i^{\mathcal{W}}$.

The *order* of $g_i^{\mathcal{W}}$ is defined inductively as follows: If $g_i^{\mathcal{W}}$ is class 1, then the order of $g_i^{\mathcal{W}}$ is the minimum of the orders of the split subtowers on the caps of $g_i^{\mathcal{W}}$ (the immersed disks that fill in the punctures of A_i^0). If $g_i^{\mathcal{W}}$ has class 2 and a single genus one first stage, then the order of $g_i^{\mathcal{W}}$ is the sum of the orders of the split subtowers on the dual pair of caps of $g_i^{\mathcal{W}}$. If $g_i^{\mathcal{W}}$ has class 2 and more than one first stage, then the order of $g_i^{\mathcal{W}}$ is the minimum of the orders of the first stages. If the class of $g_i^{\mathcal{W}}$ is greater than 2, then the order of $g_i^{\mathcal{W}}$ is defined (inductively) to be the minimum of the sums of the orders of the pairs of dual grope subtowers that are attached to the first stages of $g_i^{\mathcal{W}}$. The *order* of $g^{\mathcal{W}}$ is the minimum of the orders of the $g_i^{\mathcal{W}}$.

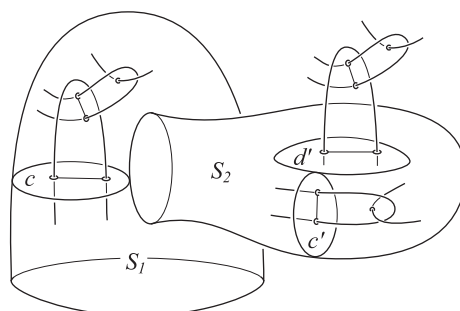

FIGURE 12. A *split grope subtower* is a collection of properly immersed capped gropes, with each cap supporting a split subtower whose other order 0 surfaces are sheets of the 0th stages of the gropes.

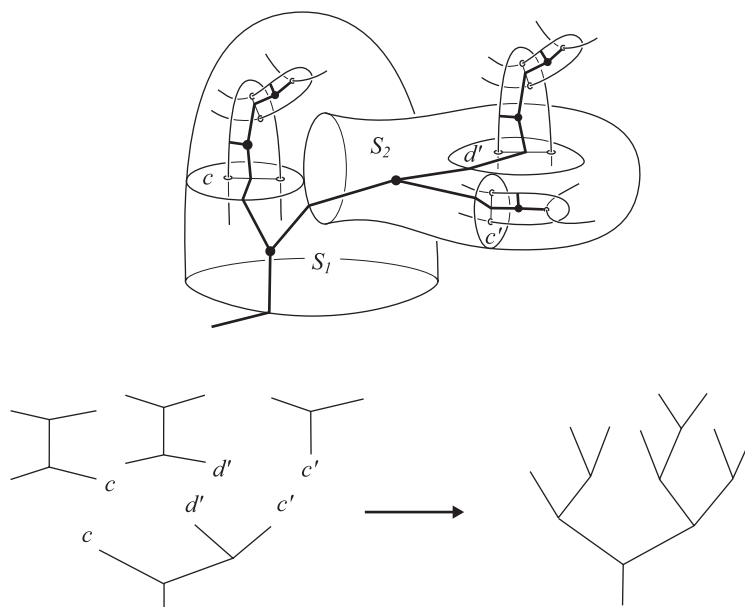

FIGURE 13. The tree $t(g^{\mathcal{W}})$ associated to a split grope subtower $g^{\mathcal{W}}$ is formed from the trees associated to the caps and gropes by gluing univalent vertices associated to common caps (bottom) and embeds in $g^{\mathcal{W}}$ (top).

4.2. Trees for dyadic split grope subtowers. For each $g_i^{\mathcal{W}}$ in a split grope subtower $g^{\mathcal{W}}$, construct the disjoint union of (rooted) univalent trees $t(g_i^{\mathcal{W}})$ from $t(g_i^c)$ (defined in Section 2.3) by gluing on the trees $t(\mathcal{W}_c)$ (defined in Section 3.3) along the univalent vertices that correspond to caps. Specifically, a univalent vertex of $t(g_i^c)$ which corresponds to a cap c in g_i^c is identified with the univalent vertex of $t(\mathcal{W}_c)$ which corresponds to c , where \mathcal{W}_c is the subtower on c . This identification is to a single non-vertex point in an edge of $t(g_i^{\mathcal{W}})$ (see the lower part of Figure 13). Doing this for all caps on g_i and all i yields all the $t(g_i^{\mathcal{W}})$. The disjoint union of

trees $t(g^{\mathcal{W}})$ associated to the split grope subtower $g^{\mathcal{W}}$ is defined to be the disjoint union of the $t(g_i^{\mathcal{W}})$ and sits as a subset of $g^{\mathcal{W}}$ (the upper part of Figure 13).

4.3. Order 0 split grope subtowers. If a class m split grope subtower $g^{\mathcal{W}}$ has order 0, then all the split subtowers \mathcal{W}_c in $g^{\mathcal{W}}$ are order 0 which just means that each cap of every g_i^c has exactly one interior intersection point with a sheet of some A_j^0 . In this case, the trees $t(g_i^{\mathcal{W}})$ and $t(g_i^c)$ are clearly isomorphic for all i and each univalent vertex corresponds to a sheet of some A_j^0 .

4.4. Class 1 split grope subtowers. If each $g_i^{\mathcal{W}}$ in an order m grope subtower $g^{\mathcal{W}}$ has class 1, then the caps fill in the punctures in the 0th stages A_i^0 to form the order 0 surfaces in an order m split Whitney tower \mathcal{W} on immersions of the A_i extending the embedded A_i^0 . The disjoint unions of trees $t(g^{\mathcal{W}})$ and $t(\mathcal{W})$ are isomorphic, with the root of each chord in $t(g_i^c)$ corresponding to an i -labelled vertex of a tree in $t(\mathcal{W})$.

5. PROOF OF THEOREM 1

The equivalence of the statements in Theorem 1 in the Introduction follows directly from the more detailed Theorems 5 and 6 which are stated and proved in this section. A key element of these theorems is that when passing between gropes and Whitney towers, the associated trees are “preserved”. In this setting, an *isomorphism* between rooted and unrooted (disjoint unions of) trees will always mean an isomorphism between the underlying unrooted trees, but will also include a correspondence between the roots and certain specified univalent vertices, e.g. the roots in $t(g_i)$ will always correspond to i -labelled univalent vertices of $t(\mathcal{W})$ when passing between gropes g_i and a Whitney tower \mathcal{W} on order zero surfaces A_i . (These isomorphisms also preserve the *signed* trees associated to gropes and Whitney towers as in [6] and [21].)

5.1. From Whitney towers to gropes.

Theorem 5. *Let \mathcal{W} be an order $(n - 1)$ Whitney tower on properly immersed surfaces A_i in a 4-manifold X . Then, for any regular neighborhood $N(\mathcal{W})$ of \mathcal{W} , there exist class n A_i -like capped gropes g_i^c in X such that:*

- (i) *The 0th stage A_i^0 of each g_i^c is A_i minus (perhaps) some sheets containing Whitney arcs or intersection points of \mathcal{W} in A_i .*
- (ii) *The union of the g_i^c are contained in $N(\mathcal{W})$.*
- (iii) *The g_i^c have disjoint properly embedded bodies g_i .*
- (iv) *Each cap of every g_i^c has a single interior intersection with some A_j^0 .*
- (v) *$t(\mathcal{W})$ is isomorphic to the disjoint union of the $t(g_i^c)$, with j -labelled univalent vertices in $t(\mathcal{W})$ corresponding to either vertices in the $t(g_i^c)$ associated to caps which intersect A_j^0 or roots in $t(g_j^c)$; furthermore, it may be arranged that this isomorphism takes any chosen preferred i -labelled univalent vertices on the trees in $t(\mathcal{W})$ to the root vertices of the trees in $t(g_i^c)$.*

The proof of Theorem 5 is well illustrated by Figure 14 together with the observation that the pictured case can always be arranged by Lemma 3.6.

Proof. First split \mathcal{W} (Lemma 3.5) so that $t(\mathcal{W})$ is the disjoint union of the split subtower trees $t(\mathcal{W}_p)$ each of order at least $n - 1$. For each \mathcal{W}_p , choose a preferred univalent vertex of $t(\mathcal{W}_p)$ and let A_i^0 denote the punctured surfaces which are the complements of the sheets of the A_i that correspond to the chosen preferred vertices. (Each of these sheets is either a neighborhood of a Whitney disk boundary arc or a neighborhood of an unpaired intersection point.) These chosen vertices will end up corresponding to root vertices in the $t(g_i^c)$ (which are associated to the 0th stages of the capped gropes g_i^c) as in statement (v) of the theorem.

Now \mathcal{W} is a grope subtower $g^{\mathcal{W}}$ of class 1 and order $(n - 1)$: The 0th stages of $g^{\mathcal{W}}$ are the A_i^0 and the caps of $g^{\mathcal{W}}$ are the sheets of the A_i that correspond to the chosen preferred vertices. The trees $t(\mathcal{W})$ and $t(g^{\mathcal{W}})$ are isomorphic. In particular, the theorem is true for $n = 1$ by Section 4.3.

Assume now that $n \geq 2$. The proof will be completed by the following construction which shows how to decrease the order of $g^{\mathcal{W}}$ while increasing the class of $g^{\mathcal{W}}$ in a manner that preserves the tree $t(g^{\mathcal{W}})$. When each cap supports an order 0 split subtower, the proof is done by Section 4.3.

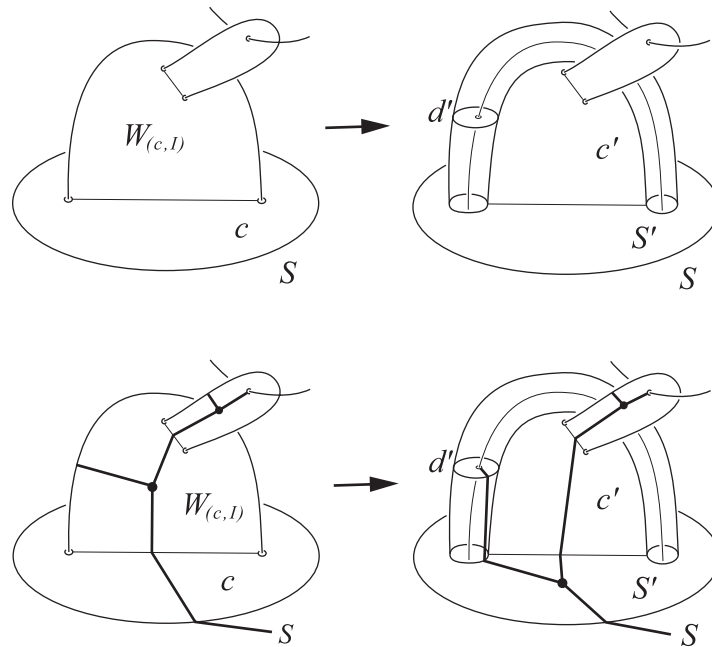

FIGURE 14. Upper left to right: Reducing the order and increasing the class of a split grope subtower $g^{\mathcal{W}}$ by 0-surgering a cap c along the boundary arc of a Whitney disk. That c contains such a boundary arc (rather than the unpaired intersection point of \mathcal{W}_c) can be arranged by Lemma 3.6. Lower left to right: This procedure preserves $t(g^{\mathcal{W}})$.

5.2. Decreasing the order and increasing the class and of a split grope subtower. Consider a cap c attached to some stage S in a grope subtower $g^{\mathcal{W}}$ such that the order of the split subtower \mathcal{W}_c supported by c is greater than or equal to

1. There are two cases to consider: Either c contains a boundary arc of a Whitney disk in \mathcal{W}_c , or c contains the unpaired intersection point p of \mathcal{W}_c .

First assume that c contains a boundary arc of a Whitney disk $W_{(c,I)}$ (see upper left of Figure 14). In this case, “tube” (0-surger) c along the (other) boundary arc of $W_{(c,I)}$ that lies in W_I as indicated in the upper right of Figure 14. This changes c into a genus one capped surface stage S' . One cap c' is $W_{(c,I)}$ minus a small collar and the other dual cap d' is a meridional disk to W_I . Both of these caps support split subtowers of order strictly less than \mathcal{W}_c , since the trees $t(\mathcal{W}_{c'})$ and $t(\mathcal{W}_{d'})$ are gotten from $t(\mathcal{W}_c)$ by removing the edge adjacent to the vertex associated to c and cutting $t(\mathcal{W}_c)$ at the vertex associated to $W_{(c,I)}$. The tree associated to the new grope subtower is the same as the original tree $t(g^{\mathcal{W}})$ since the effect of creating S' from c just isotopes (in X) the trivalent vertex (basepoint) of $t(g^{\mathcal{W}})$ in $W_{(c,I)}$ down to a trivalent vertex (basepoint) in S' as illustrated in the lower part of Figure 14.

Now assume that c contains the unpaired intersection point p of \mathcal{W}_c . We may assume that p is the intersection between c and a Whitney disk $W_{(I,J)}$ since \mathcal{W}_c has order greater than or equal to 1. Modify \mathcal{W}_c by one iteration of the procedure of Lemma 3.6: Do the $W_{(I,J)}$ Whitney move on W_I . This creates a cancelling pair of intersections between c and W_I which are paired by a Whitney disk $W_{(c,I)}$ that has a single intersection with W_J (as in Figure 11 but with different labels). The modified split subtower \mathcal{W}'_c on c has the same tree as \mathcal{W}_c , and we are back to the previous case where c contains a boundary arc of $W_{(c,I)}$. (We remark that this step where c contains the unpaired intersection point p of \mathcal{W}_c could alternatively be handled by building higher grope stages out of Clifford tori as in the *grope duality* constructions of [15] (see [23]).) □

5.3. From gropes to Whitney towers. The gropes in the statement of Theorem 1 can be arranged to satisfy the hypotheses of the next theorem by using finger moves to push down cap-intersections (2.5 of [10]) into the order 0 surfaces and by applying Krushkal’s grope splitting technique [13].

Theorem 6. *Let g_i^c be a collection of class n A_i -like dyadic capped gropes in a 4-manifold X with disjoint properly embedded bodies g_i , such that all the caps have disjointly embedded interiors and each cap contains only a single interior intersection point with some 0th stage A_j^0 . Then, for any regular neighborhood $N(g_i^c)$ of the union of the g_i^c , there exists an order $(n - 1)$ Whitney tower \mathcal{W} in X such that:*

- (i) \mathcal{W} is contained in $N(g_i^c)$.
- (ii) The order 0 surfaces of \mathcal{W} are immersions of the A_i extending the embeddings A_i^0 up to regular homotopy (rel ∂).
- (iii) $t(\mathcal{W})$ is isomorphic to the disjoint union of the $t(g_i^c)$ with j -labelled univalent vertices in $t(\mathcal{W})$ corresponding to either vertices in the $t(g_i^c)$ associated to caps which intersect A_j^0 or roots in $t(g_j^c)$.

The proof of Theorem 6 is well illustrated by Figure 15 together with the observation that the pictured case can always be arranged by Lemma 3.6.

Proof. When $n = 1$, the g_i^c form a grope subtower $g^{\mathcal{W}}$ of class 1 and the theorem is true by Section 4.4.

Assuming $n \geq 2$, the proof is completed by the following construction (essentially the inverse to the construction of Section 5.2 in the proof of Theorem 5) which decreases the class and increases the order of a grope subtower $g^{\mathcal{W}}$ while preserving

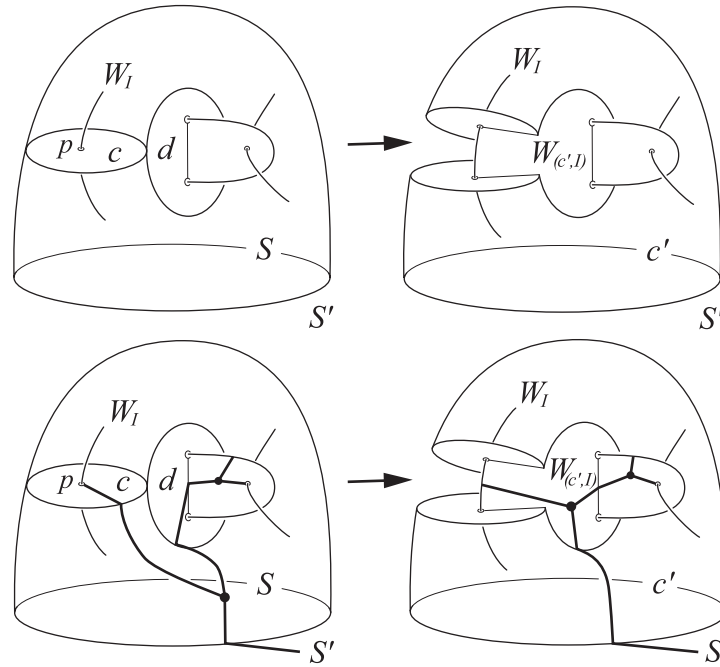

FIGURE 15. Upper left to right: Surgering one of a dual pair of caps in a split grope subtower $g^{\mathcal{W}}$ reduces the class and increases the order of $g^{\mathcal{W}}$. This procedure requires the surgered cap c to contain the unpaired intersection point p in its split subtower \mathcal{W}_c as can be arranged by Lemma 3.6. Lower left to right: This surgery preserves $t(g^{\mathcal{W}})$.

the associated trees. When each g_i^c in $g^{\mathcal{W}}$ has class 1, the proof is complete by Section 4.4.

5.4. Decreasing the class and increasing the order of a grope subtower.

Let c and d be a pair of dual caps on a surface stage S in a grope subtower $g^{\mathcal{W}}$ supporting split subtowers \mathcal{W}_c and \mathcal{W}_d . By applying Lemma 3.6 to \mathcal{W}_c , we may arrange that c contains the unpaired intersection point $p = c \cap W_I$ in \mathcal{W}_c . Using c to ambiently surger S changes S into a cap c' on the stage S' below S . This new cap c' has a cancelling pair of intersections with W_I (due to p , the intersection c had with W_I), which can be paired with a Whitney disk $W_{(c',d)}$ formed from the old cap d by attaching a thin band as pictured in the upper right of Figure 15. The cap c' supports a split subtower $\mathcal{W}_{c'}$ and, as illustrated in the lower part of Figure 15, there is no change in $t(g^{\mathcal{W}})$ since the effect of the surgery is just to isotope (in X) the univalent vertex of $t(g^{\mathcal{W}})$ that was in S up into $W_{(c',d)}$. (Here we are still denoting the modified grope subtower by $g^{\mathcal{W}}$.) Repeated application of this construction eventually eliminates all dual pairs of caps so that each g_i^c in $g^{\mathcal{W}}$ has class 1. \square

6. PROOF OF COROLLARY 2

The idea of the proof of Corollary 2 in the Introduction is to use Theorem 6 of Subsection 5.3 to convert the symmetric grope into a Whitney tower whose associated trees are all symmetric and then use Lemma 3.6 to create the desired Whitney tower by moving the unpaired intersection points appropriately. The gropes in this section are disk-like and assumed to be dyadic as can always be arranged by Krushkal’s splitting procedure [13].

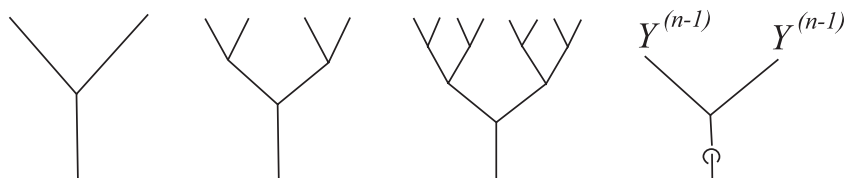

FIGURE 16. From left to right: The trees Y^1 , Y^2 , Y^3 and (a punctured) Y^n .

6.1. Symmetric gropes and trees. Let Y^1 denote the order 1 rooted Y -shaped tree that corresponds to a punctured torus viewed as a grope of class 2 (with the bottom univalent vertex designated as the root). For integers $n > 1$, define $Y^{(n+1)}$ to be the rooted product $Y^n * Y^n$ (see Figure 16). A grope g is *symmetric* and has *height* n if all the trees in $t(g)$ are of the form Y^n . For $n \geq 1$, define the tree $Y^{(n.5)}$ to be the rooted product $Y^{(n-1)} * Y^n$ (where Y^0 is the rooted chord). A grope g has *height* $n.5$ if all the trees in $t(g)$ are of the form $Y^{(n.5)}$. Note that a grope of height n (resp. $n.5$) has class 2^n (resp. $2^n + 2^{(n-1)} = (1.5)(2^n)$).

6.2. The height of a Whitney tower. Translating the definition of height given in [5] into our language we have: An order $(2^n - 2)$ Whitney tower \mathcal{W} has *height* n ($n \geq 1$) if the interiors of all Whitney disks in \mathcal{W} only intersect surfaces of the same order. Thus, the lowest order unpaired intersections in a Whitney tower of height n are of order $(2^{(n-1)} - 1) + (2^{(n-1)} - 1) = 2^n - 2$ and occur among the highest order Whitney disks (of order $2^{(n-1)} - 1$).

A Whitney tower of *height* $n.5$ ($n \geq 1$) is a Whitney tower of height n , together with order $2^n - 1$ Whitney disks pairing all order $2^n - 2$ intersection points with the requirement that the interiors of these order $2^n - 1$ Whitney disks may intersect each other and the order $2^{(n-1)} - 1$ Whitney disks but are disjoint from all surfaces of lower order. A Whitney tower of height $n.5$ has order $2^n + 2^{(n-1)} - 2$.

Proof of Corollary 2. Applying Theorem 6 of Section 5 to a disk-like grope g of height n (resp. $n.5$) yields a Whitney tower \mathcal{W} of order $2^n - 1$ (resp. $2^{(n-1)} + 2^n - 1$) with $t(\mathcal{W})$ isomorphic to $t(g)$ so that all the connected trees in $t(\mathcal{W})$ are of the form Y^n (resp. $Y^{(n.5)}$). After splitting \mathcal{W} (Lemma 3.5) and applying Lemma 3.6, we may arrange that the punctured edge in each punctured tree $t^\circ(p)$ in $t^\circ(\mathcal{W})$ is adjacent to (what was) a root vertex, that is, the only unpaired intersection points of \mathcal{W} occur between the order zero 2-disk and Whitney disks whose associated trees are of the form Y^n (resp. $Y^{(n.5)}$) as in the far right of Figure 16. The Whitney disks of \mathcal{W} correspond to the trivalent vertices of $t(\mathcal{W})$, and one can check by examining the

shape of the Y^n trees which make up $t^\circ(\mathcal{W})$ that \mathcal{W} satisfies the above definition of height n (resp. $n.5$). In fact, \mathcal{W} satisfies the stronger condition that its intersections of order $2^n - 2$ (between Whitney disks of order $2^{(n-1)} - 1$), which are allowed to be unpaired in [5], are in fact all paired by order $2^n - 1$ Whitney disks (each of which corresponds to the trivalent vertex adjacent to the root of a Y^n). This is as expected by Theorem 1 since \mathcal{W} should have order $2^n - 1$. However, these order $2^n - 1$ Whitney disks intersect the order zero 2-disk so that \mathcal{W} does *not* have height $n + 1$. The case of half-integer height $n.5$ is checked similarly. \square

7. PROOF OF COROLLARY 3 AND THE WHITNEY MOVE IHX CONSTRUCTION

This section contains a proof of Corollary 3 which is based on a geometric realization of the IHX Jacobi relation in the setting of Whitney towers (Lemma 7.2 below). A dyadic (capped) A -like grope g is a *half-grope* if all the trees in $t(g)$ are *simple* (right- or left-normed) as illustrated in Figure 17; note that the roots (shown pointing down in the figure) are required to be at an “end” of the tree.

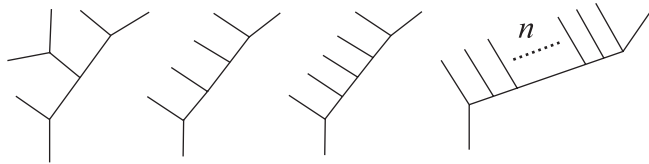

FIGURE 17. From left to right: The non-simple tree of lowest order (order 4) and the simple trees of order 4, 5, and $6 + n$.

Proof. To prove Corollary 3, choose caps for the class n g_i (which we may assume are dyadic) and use Theorem 6 of Section 5 to convert the g_i^c into a Whitney tower \mathcal{W} of order $n - 1$. By the following Proposition 7.1, \mathcal{W} can be modified (rel boundary) to a Whitney tower \mathcal{W}' (of the same order) with $t(\mathcal{W}')$ consisting of only simple trees. Then converting \mathcal{W}' back into a grope via Theorem 5 of Section 5 yields the desired half gropes h_i in X bounded by γ_i . (Here we are using (v) of Theorem 5 to send chosen univalent “end vertices” to roots, while preserving trees.) \square

Proposition 7.1. *Let \mathcal{W} be any order n Whitney tower on order 0 surfaces A_i . Then, after a regular homotopy (rel ∂), the A_i admit an order n simple Whitney tower \mathcal{W}' contained in a neighborhood of \mathcal{W} , that is, $t(\mathcal{W}')$ consists of only simple trees.*

The proof of Proposition 7.1 uses the geometric IHX Lemma 7.2 below to follow the algebraic proof that the usual group of univalent trees occurring in finite type theory is spanned by simple trees as given in e.g., [1], [7]:

Proof. The simple trees are characterized by the property that any maximal length chain of edges contains every trivalent vertex. Let $t(p) = t(\mathcal{W}_p) \in t(\mathcal{W})$ be a tree associated to a split subtower $\mathcal{W}_p \subset T$ contained in a Whitney tower \mathcal{W} (which we may assume is split by Lemma 3.5). If $t(p)$ contains a trivalent vertex v_1 which is of distance 1 away from a trivalent vertex v_0 contained in some maximal chain of edges not containing v_1 , then we may assume, by Lemma 3.6, that v_0 corresponds to $W_{(I,J)}$ and v_1 corresponds to $W_{((I,J),K)}$, which is incident to some other sheet

W_L in \mathcal{W}_p as in left-hand side of Figure 18. Lemma 7.2 below shows how to modify \mathcal{W} near \mathcal{W}_p so as to replace $t(p) \in t(\mathcal{W})$ by the two trees on the right-hand side of Figure 18 having the same order as $t(p)$ but with longer length edge chains. By iterating this modification (for all components of $t(\mathcal{W})$) we eventually arrive at the desired \mathcal{W}' with all components of $t(\mathcal{W}')$ simple trees. \square

Lemma 7.2 (Geometric IHX–Whitney move version). *Let \mathcal{W}_p be a split subtower in a split Whitney tower \mathcal{W} . Let $W_{((I,J),K)}$ be a Whitney disk in \mathcal{W}_p so that $t(\mathcal{W}_p)$ looks locally like the leftmost tree in Figure 18. Then \mathcal{W} can be modified in a regular neighborhood $\nu(\mathcal{W}_p)$ of \mathcal{W}_p yielding a split Whitney tower \mathcal{W}' , on the same order 0 surfaces, with \mathcal{W}_p replaced by disjoint split subtowers $\mathcal{W}_{p'}$ and $\mathcal{W}_{p''}$ contained in $\nu(\mathcal{W}_p)$ such that the trees $t(\mathcal{W}_{p'})$ and $t(\mathcal{W}_{p''})$ are as pictured on the right-hand side of Figure 18.*

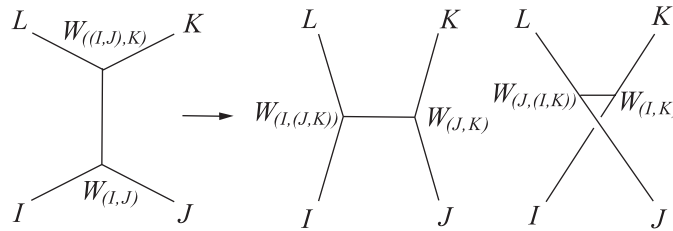

FIGURE 18. The IHX relation for Whitney disks in a split subtower replaces a split subtower whose tree looks locally like the one on the left with a pair of nearby disjoint split subtowers whose trees look locally like the trees on the right.

The modification involves Whitney moves, finger moves and taking parallel copies of some of the Whitney disks in \mathcal{W}_p . The reader familiar with the orientation and sign conventions of [21] can check by inserting signs and orientations in the figures that the following construction actually replaces an “I” tree with the difference “H – X” as in the usual IHX relation of finite type theory. Note that this differs from the closely related 4–dimensional IHX construction in [6] which creates the trees $I - H + X$ for a Whitney tower on 2–spheres in 4–space by modifying the boundaries of Whitney disks.

Proof. The first step in the modification is to do the $W_{(I,J)}$ Whitney move on W_I (see Figure 19) and disregard, for the moment, the Whitney disks in the part of \mathcal{W} corresponding to the sub-tree L . This eliminates the cancelling pair of intersections between W_I and W_J at the cost of creating two cancelling pairs of intersections between W_I and W_K which we pair by Whitney disks $W_{(I,K)}$ and $W'_{(I,K)}$ as illustrated in Figure 19. The new Whitney disks $W_{(I,K)}$ and $W'_{(I,K)}$ each have a single interior intersection with W_J and the next step is to “transfer” (as illustrated in the upper part of Figure 20) the intersection point $W_J \cap W'_{(I,K)}$ to create a cancelling pair $W_J \cap W_{(I,K)}$ paired by $W_{(J,(I,K))}$ at the cost of also creating $W_J \cap W_K$ paired by $W_{(J,K)}$ and $W_I \cap W_{(J,K)}$ paired by $W_{(I,(J,K))}$ (as illustrated in the lower part of Figure 20). Note that Figure 20 differs from Figure 19 by a rotation of coordinates which brings the sheet of W_K into the “present” slice of 3–space. This transfer

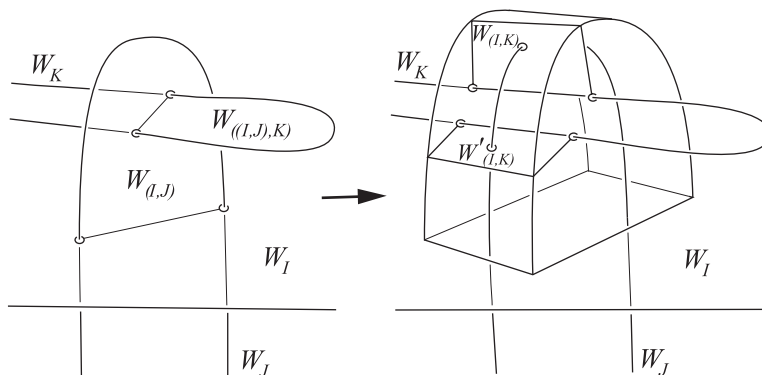

FIGURE 19. The IHX construction starts with a $W_{(I,J)}$ Whitney move on W_I . Note that intersections between $W_{((I,J),K)}$ and W_L are *not* shown in this figure (and are suppressed in subsequent figures as well).

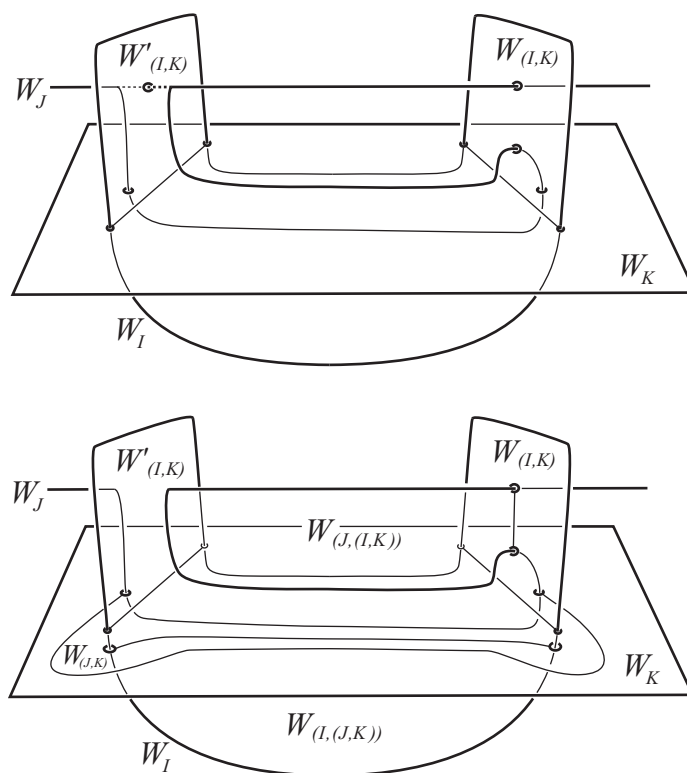

FIGURE 20. The intersection point $W_J \cap W'_{(I,K)}$ is ‘transferred’ via a finger move (top) to create a cancelling pair $W_J \cap W_{(I,K)}$ paired by $W_{(J,(I,K))}$ at the cost of also creating $W_J \cap W_K$ paired by $W_{(J,K)}$ and $W_I \cap W_{(J,K)}$ paired by $W_{(I,(J,K))}$ (bottom).

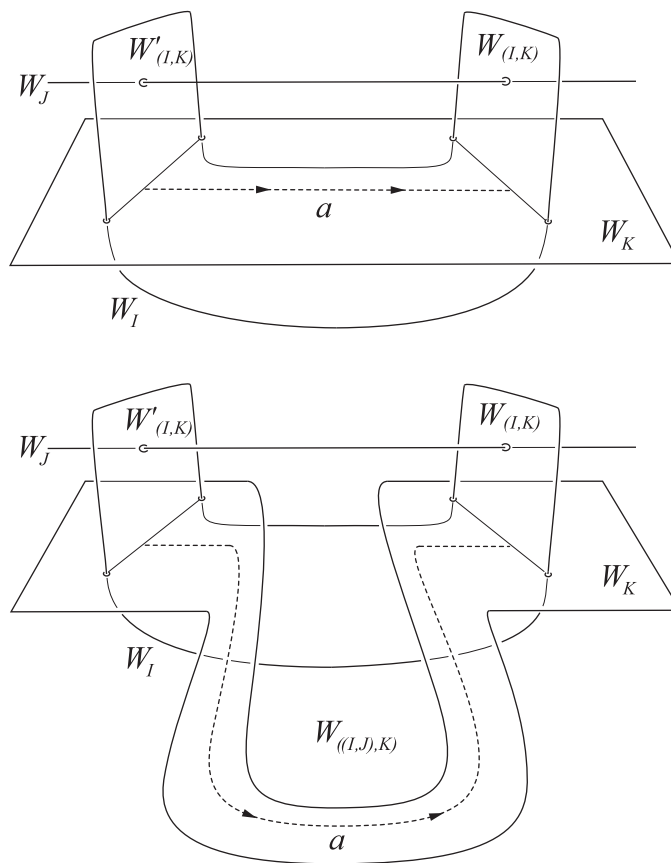

FIGURE 21. The transferring finger move is guided by an arc a (top) which can be taken to run along what used to be the part of the boundary arc of $W_{((I,J),K)}$ lying in W_K (bottom). Indicated in the bottom picture is where $W_{((I,J),K)}$ used to be.

move was described in [26] (see also [20] and [19]) and is just a (non-generic) finger move applied to W_J . The important thing to note here is that the finger move is guided by an arc a (see Figure 21) from $\partial W'_{(I,K)}$ to $\partial W_{(I,K)}$ in W_K and we can take this arc to run along what used to be the part of $\partial W_{((I,J),K)}$ lying in W_K . This is illustrated in the lower part of Figure 21 which gives a better picture of the situation before the finger move is applied. The Whitney disks $W_{(I,(J,K))}$ and $W_{(J,(I,K))}$ can be taken to be parallel copies of the old $W_{((I,J),K)}$ as follows: The boundary of $W_{(I,(J,K))}$ (resp. $W_{(J,(I,K))}$) consists of arcs a' and b' (resp. a'' and b''), where a' and a'' are tangential push-offs of a in W_K and b' and b'' are normal push-offs of what was the boundary arc b of $W_{((I,J),K)}$ in $W_{(I,J)}$. This is shown in both Figure 22 and Figure 23, where again it is easier to picture things before the transferring finger move. Since $W_{((I,J),K)}$ was framed and embedded, $W_{(I,(J,K))}$ and $W_{(J,(I,K))}$ can be formed from two disjoint parallel copies of $W_{((I,J),K)}$ which each intersect W_L as $W_{((I,J),K)}$ did. Two parallel copies of each Whitney disk that was in the part of \mathcal{W}_p corresponding to L can be used to recover the order of

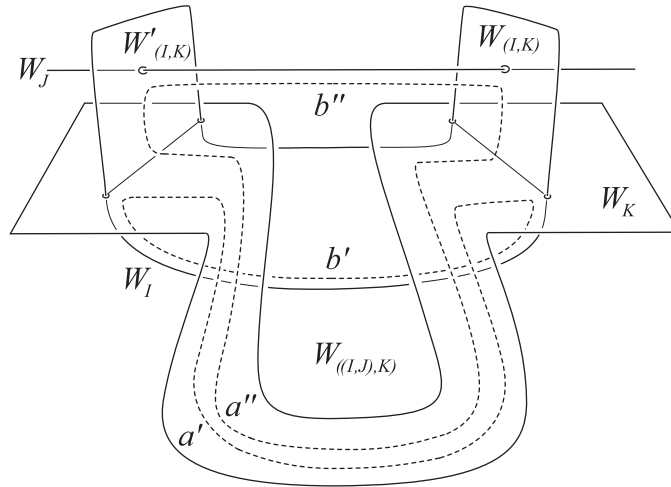

FIGURE 22. Before the transfer move: New Whitney disks $W_{(I,(J,K))}$ and $W_{(J,(I,K))}$, whose boundaries are the unions of arcs $a' \cup b'$ and $a'' \cup b''$ (see also Figure 23), will be created from parallel copies of the old $W_{((I,J),K)}$.

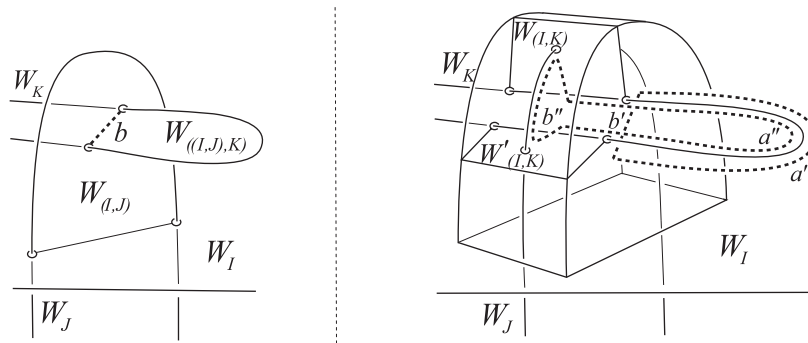

FIGURE 23. Applying the transfer move to the right-hand side will create new Whitney disks $W_{(I,(J,K))}$ and $W_{(J,(I,K))}$, whose boundaries are the unions of arcs $a' \cup b'$ and $a'' \cup b''$ (see also Figure 22), from parallel copies of the old $W_{((I,J),K)}$ shown on the left.

the original Whitney tower (by pairing the new intersections “over” $W_{(I,(J,K))}$ and $W_{(J,(I,K))}$ corresponding to L), which means that exactly two new unpaired intersection points p' and p'' have been created with corresponding trees $t(p')$ and $t(p'')$ as shown locally in the right-hand side of Figure 18. After the transferring finger move, the $W'_{(I,K)}$ Whitney move can be done (on either sheet) without affecting anything else. Finally, W_I, W_J and W_K will need to be split since they now each contain two boundary arcs of Whitney disks. Splitting W_I, W_J and W_K down into

the lower order Whitney disks (as in Lemma 3.5) yields the two split subtowers $\mathcal{W}_{p'}$ and $\mathcal{W}_{p''}$. \square

8. PROOF OF COROLLARY 4

In this section the main theorems together with the geometric IHX construction of the previous section are used to prove Corollary 4 in the Introduction. We refer the reader to [2] or [12] for the formal definition of k -null-cobordism or k -slice. It is enough to show that the link components in $S^3 = \partial B^4$ bound disjointly embedded surfaces A_i such that each A_i contains a symplectic basis of circles which bound continuous maps of class k grope in $B^4 \setminus \bigcup_i A_i$. In fact, we will find such A_i with symplectic bases of circles bounding *embedded* class k grope in $B^4 \setminus \bigcup_i A_i$. The same proof shows that class $2k$ grope concordant links are k -cobordant.

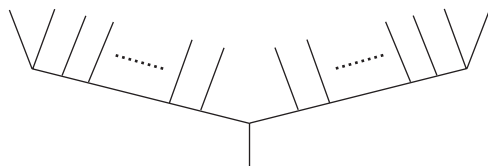

FIGURE 24. A simple tree associated to an order $2k-1$ (or greater) intersection point in an order $2k-1$ Whitney tower \mathcal{W} with a preferred univalent vertex (at least) $k-1$ trivalent vertices away from both ends. Using Theorem 5 of Section 5 to convert \mathcal{W} to disjoint grope g_i with all such preferred univalent vertices going to roots in $t(g_i)$ yields k -slicing surfaces (the bottom stages of the g_i).

Proof. Apply Krushkal's grope-splitting procedure [13] and Theorem 6 of Section 5 to the class $2k$ (disk-like) grope (as in the hypotheses of Corollary 4) to get an order $2k-1$ Whitney tower on immersed 2-disks bounded by the link components in B^4 . Then apply Proposition 7.1 to get a Whitney tower \mathcal{W} with $t(\mathcal{W})$ consisting of only simple trees. Since the order of \mathcal{W} is $2k-1$, the order of each tree in $t(\mathcal{W})$ is at least $2k-1$. This means that we can specify a preferred univalent vertex in each simple tree in $t(\mathcal{W})$ such that the trivalent vertex adjacent to the preferred univalent vertex is at least $k-1$ trivalent vertices away from both ends of the simple tree, as illustrated in Figure 24. Now use Theorem 5 of Section 5 to convert back to disjointly embedded (disk-like) grope g_i with the preferred univalent vertices in $t(\mathcal{W})$ going to the root vertices in the $t(g_i)$. As is seen in the shape of the trees $t(g_i)$ (Figure 24), the desired A_i are the class 2 sub-grope formed by the bottom (0th and 1st) stages of the g_i and the higher (≥ 2) stages form class k grope which are attached to symplectic bases on the A_i and disjointly embedded in $B^4 \setminus \bigcup_i A_i$. \square

REFERENCES

- [1] D. Bar-Natan. *Vassiliev homotopy string link invariants*, J. Knot Theory Ramifications 4 (1995) 13–32. MR1321289 (96b:57004)
- [2] T. Cochran. *k -cobordism for links in S^3* , Trans. A.M.S. Vol. 327 No. 2 (1991) 641–654. MR1055569 (92a:57003)
- [3] T. Cochran. *Geometric invariants of link cobordism*, Comment. Math. Helv. Vol. 60 (1985) 291–311. MR0800009 (87f:57021)

- [4] T. Cochran. *Derivatives of links, Milnor's concordance invariants and Massey products*, Mem. Amer. Math. Soc. Vol. 84 No. 427 (1990). MR1042041 (91c:57005)
- [5] T. Cochran, K. Orr and P. Teichner. *Knot concordance, Whitney towers and L^2 -signatures*, Annals of Math. Vol. 157 No.2 (2003) 433-519. MR1973052 (2004i:57003)
- [6] J. Conant, R. Schneiderman and P. Teichner. *Jacobi identities in low-dimensional topology*, Preprint (2004).
- [7] J. Conant and P. Teichner, *Grope cobordism of classical knots*, Topology, Vol. 43, Issue 1 (2004); 119-156. MR2030589 (2004k:57006)
- [8] J. Conant and P. Teichner, *Grope cobordism and Feynman diagrams*, Math. Annalen Vol. 328 Nos. 1-2 (2004), 135-171. MR2030373
- [9] M. H. Freedman. *The topology of four-dimensional manifolds*, J. Diff. Geom. 17 (1982) 357-453. MR0679066 (84b:57006)
- [10] M. H. Freedman and F. Quinn. *The topology of 4-manifolds*, Princeton Math. Series 39 Princeton NJ (1990). MR1201584 (94b:57021)
- [11] M. H. Freedman and P. Teichner. *4-manifold topology II: Dwyer's filtration and surgery kernels*, Invent.Math. 122 (1995) 531-557. MR1359603 (96k:57016)
- [12] K. Igusa and K. Orr. *Links, pictures and the homology of nilpotent groups*, Topology 40 (2001) 1125-1166. MR1867241 (2003a:57011)
- [13] V. Krushkal. *Exponential separation in 4-manifolds*, Geometry and Topology Vol. 4 (2000) 397-405. MR1796497 (2001i:57030)
- [14] V. Krushkal and F. Quinn. *Subexponential groups in 4-manifold topology*, Geometry and Topology Vol. 4 (2000) 407-430. MR1796498 (2001i:57031)
- [15] V. Krushkal and P. Teichner. *Alexander duality, gropes and link homotopy*, Geometry and Topology Vol. 1 (1997) 51-69. MR1475554 (98i:57013)
- [16] W. Magnus, A. Karass and D. Solitar, *Combinatorial group theory*, Dover Publications Inc. (1976).
- [17] K. Orr. *Homotopy invariants of links*, Invent. Math. Vol. 95 (1989) 379-394. MR0974908 (90a:57012)
- [18] F. Quinn. *Embedding towers in 4-manifolds*, Four-manifold Theory AMS Contemporary Math 35 (1984) 461-472. MR0780593 (86f:57014)
- [19] R. Schneiderman *Simple Whitney towers, half-gropes and the Arf invariant of a knot*, Preprint (2002) <http://front.math.ucdavis.edu/math.GT/0310304>.
- [20] R. Schneiderman and P. Teichner. *Higher order intersection numbers of 2-spheres in 4-manifolds*, Algebraic and Geometric Topology Vol. 1 (2001) 1-29. MR1790501 (2002c:57036)
- [21] R. Schneiderman and P. Teichner. *Whitney towers and the Kontsevich integral*, Preprint (2003) (to appear in *Proceedings of the CassonFest* Geometry and Topology Monograph Series).
- [22] R. Schneiderman and P. Teichner. *Pulling apart 2-spheres in 4-manifolds*, in preparation.
- [23] R. Schneiderman and P. Teichner. *Grope concordance of classical links*, in preparation.
- [24] P. Teichner, *What is ... a grope?*, To appear in the Notices of the A.M.S.
- [25] H. Whitney. *The self intersections of a smooth n -manifold in $2n$ -space*, Annals of Math. 45 (1944) 220-246. MR0010274 (5:273g)
- [26] M. Yamasaki. *Whitney's trick for three 2-dimensional homology classes of 4-manifolds*, Proc. Amer. Math. Soc. 75 (1979) 365-371. MR0532167 (80k:57024)

COURANT INSTITUTE OF MATHEMATICAL SCIENCES, NEW YORK UNIVERSITY, 251 MERCER STREET, NEW YORK, NEW YORK 10012-1185

E-mail address: schneiderman@courant.nyu.edu