

WEAK REGULARITY AND FINITELY FORCIBLE GRAPH LIMITS

JACOB W. COOPER, TOMÁŠ KAISER, DANIEL KRÁL', AND JONATHAN A. NOEL

ABSTRACT. Graphons are analytic objects representing limits of convergent sequences of graphs. Lovász and Szegedy conjectured that every finitely forcible graphon, i.e., any graphon determined by finitely many graph densities, has a simple structure. In particular, one of their conjectures would imply that every finitely forcible graphon has a weak ε -regular partition with the number of parts bounded by a polynomial in ε^{-1} . We construct a finitely forcible graphon W such that the number of parts in any weak ε -regular partition of W is at least exponential in $\varepsilon^{-2}/2^{5 \log^* \varepsilon^{-2}}$. This bound almost matches the known upper bound for graphs and, in a certain sense, is the best possible for graphons.

1. INTRODUCTION

The theory of combinatorial limits has recently attracted a significant amount of attention. This line of research was sparked by limits of dense graphs [7–9, 32], which we focus on here, followed by limits of other structures, e.g., permutations [22, 23, 28], sparse graphs [5, 14], and partial orders [25]. Methods related to combinatorial limits have led to substantial results in many areas of mathematics and computer science, particularly in extremal combinatorics. For example, the notion of flag algebras, which is strongly related to combinatorial limits, resulted in progress on many important problems in extremal combinatorics [1–4, 19–21, 26, 27, 34–38]. Theory of combinatorial limits also provided a new perspective on existing concepts in other areas, e.g., property testing algorithms in computer science [16, 24, 33].

A convergent sequence of dense graphs can be represented by an analytic object called a *graphon*. Let $d(H, W)$ be the density of a graph H in a graphon W (a formal definition is given in Section 2). A graphon W is said to be *finitely forcible* if it is determined by finitely many graph densities; i.e., there exist graphs H_1, \dots, H_k and reals d_1, \dots, d_k such that W is the unique graphon with $d(H_i, W) = d_i$. Finitely forcible graphons appear in many different settings, one of which is in extremal combinatorics. It is known that if a graphon is finitely forcible, then it is the unique graphon which minimizes a fixed finite linear combination of subgraph densities,

Received by the editors July 6, 2015, and, in revised form, July 20, 2016, and August 26, 2016.
2010 *Mathematics Subject Classification*. Primary 05C35, 05C80.

The work of the first and third authors leading to this invention has received funding from the European Research Council under the European Union's Seventh Framework Programme (FP7/2007-2013)/ERC grant agreement no. 259385.

The second author was supported by the grant GA14-19503S (Graph coloring and structure) of the Czech Science Foundation.

The work of the third author was also supported by the Engineering and Physical Sciences Research Council Standard Grant number EP/M025365/1.

i.e., finitely forcible graphons are extremal points of the space of all graphons. The following conjecture [31, Conjecture 7] claims that the converse is also true.

Conjecture 1. *Let H_1, \dots, H_k be finite graphs and let $\alpha_1, \dots, \alpha_k$ be reals. There exists a finitely forcible graphon W that minimizes the sum $\sum_{i=1}^k \alpha_i d(H_i, W)$.*

Finitely forcible graphons are also related to quasirandomness in graphs as studied e.g. by Chung, Graham, and Wilson [10], Rödl [39], and Thomason [40, 41]. In the language of graph limits, results on quasirandom graphs state that every constant graphon is finitely forcible. A generalization of this statement was proven by Lovász and Sós [30]: every step graphon (i.e., a multipartite graphon with a finite number of parts and uniform edge densities between its parts) is finitely forcible.

In [31], Lovász and Szegedy carried out a more systematic study of finitely forcible graphons. The examples of finitely forcible graphons that they constructed led to a belief that finitely forcible graphons must have a simple structure. To formalize this, they introduced the (topological) space $T(W)$ of typical vertices of a graphon W and conjectured the following [31, Conjectures 9 and 10].

Conjecture 2. *The space of typical vertices of every finitely forcible graphon is compact.*

Conjecture 3. *The space of typical vertices of every finitely forcible graphon has a finite dimension.*

Both conjectures were disproved through counterexample constructions in [17, 18].

Conjecture 3 is a starting point of our work. Analogously to weak regularity of graphs, every graphon has a weak ε -regular partition with at most $2^{O(\varepsilon^{-2})}$ parts. (See Section 3 for the necessary definitions.) If the space of typical vertices of a graphon is equipped with an appropriate metric, then its Minkowski dimension is linked to the number of parts in its weak regular partitions. In particular, if its Minkowski dimension is d , then the graphon has weak ε -regular partitions with $O(\varepsilon^{-d})$ parts. Consequently, if Conjecture 3 were true, the number of parts of a weak ε -regular partition of a finitely forcible graphon would be bounded by a polynomial of ε^{-1} . The number of parts in weak ε -regular partitions of a graphon constructed in [17] as a counterexample to Conjecture 3 is $2^{\Theta(\log^2 \varepsilon^{-1})}$, which is a superpolynomial in ε^{-1} , but is much smaller than the general upper bound of $2^{O(\varepsilon^{-2})}$. We construct a finitely forcible graphon almost matching the upper bound.

Theorem 1. *There exist a finitely forcible graphon W and positive reals ε_i tending to 0 such that every weak ε_i -regular partition of W has at least $2^{\Omega\left(\varepsilon_i^{-2}/2^{5 \log^* \varepsilon_i^{-2}}\right)}$ parts.*

As pointed out to us by Jacob Fox, there is no graphon (finitely forcible or not) matching the upper bound $2^{O(\varepsilon^{-2})}$ for infinitely many values of ε tending to 0. In light of this, Theorem 1 is almost the best possible.

Proposition 2. *There exist no graphon W , a positive real c , and positive reals ε_i tending to 0 such that every weak ε_i -regular partition of W has at least $2^{c\varepsilon_i^{-2}}$ parts.*

The proof of this proposition is sketched at the end of Section 3.

We will refer to the graphon W from Theorem 1 as the Švejk graphon. Švejk is the name of a famous (and fictitious) brave Czech soldier, and, more importantly for us, it is the name of the restaurant where we usually ate lunch during our work on this subject while three of us were visiting the University of West Bohemia in Pilsen.

2. GRAPH LIMITS

We now introduce notions related to graphons and convergent sequences of graphs. The *density* of a graph H in G , which is denoted by $d(H, G)$, is the probability that $|H|$ randomly chosen vertices of G induce a subgraph isomorphic to H , where $|H|$ is the order (the number of vertices) of H . A sequence of graphs $(G_n)_{n \in \mathbb{N}}$ with the number of their vertices tending to infinity is *convergent* if the sequence $d(H, G_n)$ converges for every graph H . Note that if G_n has $o(|G_n|^2)$ edges, then the sequence $(G_n)_{n \in \mathbb{N}}$ is convergent for trivial reasons. Hence, this notion of graph convergence is of interest for sequences of dense graphs, i.e., graphs with $\Omega(|G_n|^2)$ edges.

A convergent sequence of dense graphs can be represented by an analytic object called a graphon. A *graphon* W is a measurable function from $[0, 1]^2$ to $[0, 1]$ that is symmetric; i.e., it holds that $W(x, y) = W(y, x)$ for every $x, y \in [0, 1]$. The points in $[0, 1]$ are often referred to as the *vertices* of the graphon W .

If W is a graphon, then a *W -random graph* of order k is obtained by sampling k random points $x_1, \dots, x_k \in [0, 1]$ uniformly and independently and joining the i -th and the j -th vertices by an edge with probability $W(x_i, x_j)$. The *density* of a graph H in a graphon W is the probability that a W -random graph of order $|H|$ is isomorphic to H . If $(G_n)_{n \in \mathbb{N}}$ is a convergent sequence of graphs, then there exists a graphon W such that $d(H, W) = \lim_{n \rightarrow \infty} d(H, G_n)$ for every graph H [32]. This graphon can be viewed as the limit of the sequence $(G_n)_{n \in \mathbb{N}}$. On the other hand, a sequence of W -random graphs of increasing orders is convergent with probability one, and its limit is the graphon W .

Two graphons W_1 and W_2 are *weakly isomorphic* if there exist measure preserving maps φ_1 and φ_2 from $[0, 1]$ to $[0, 1]$ such that $W_1(\varphi_1(x), \varphi_1(y)) = W_2(\varphi_2(x), \varphi_2(y))$ for almost every pair $(x, y) \in [0, 1]^2$. If two graphons W_1 and W_2 are weakly isomorphic, then $d(H, W_1) = d(H, W_2)$ for every graph H . The converse is also true [6]: if two graphons W_1 and W_2 satisfy that $d(H, W_1) = d(H, W_2)$ for every graph H , then W_1 and W_2 are weakly isomorphic. Hence, the limit of a convergent sequence of graphs is unique up to weak isomorphism. We finish by giving a formal definition of a finitely forcible graphon: a graphon W is *finitely forcible* if there exist graphs H_1, \dots, H_k such that if a graphon W' satisfies that $d(H_i, W') = d(H_i, W)$ for $i = 1, \dots, k$, then $d(H, W') = d(H, W)$ for every graph H .

3. WEAK REGULAR PARTITIONS

In this section, we recall some basic concepts related to weak regularity for graphs and graphons and cast the lower bound construction of Conlon and Fox from [11] in the language of graphons. Since we do not use any other type of regularity partition, we will just say “regular” instead of “weak regular” in what follows.

We start by defining the notion for graphs. If G is a graph and A and B are two subsets of its vertices, let $e(A, B)$ be the number of edges uv such that $u \in A$ and

$v \in B$. A partition of a vertex set $V(G)$ of a graph G into subsets V_1, \dots, V_k is said to be ε -regular if it holds that

$$\left| e(A, B) - \sum_{i,j \in [k]} \frac{e(V_i, V_j)}{|V_i||V_j|} |V_i \cap A||V_j \cap B| \right| \leq \varepsilon |V(G)|^2$$

for every two subsets A and B of $V(G)$. It is known that for every $\varepsilon > 0$, there exists $k_0 \leq 2^{O(\varepsilon^{-2})}$ (which depends on ε only) such that every graph has an ε -regular partition with at most k_0 parts [15]. This dependence of k_0 on ε is best possible up to a constant factor in the exponent as shown by Conlon and Fox [11].

We now define the analogous notion for graphons. Let $W : [0, 1]^2 \rightarrow [0, 1]$ be a graphon. If A and B are two measurable subsets of $[0, 1]$, then the *density* $d_W(A, B)$ between A and B is defined to be

$$d_W(A, B) = \int_{A \times B} W(x, y) \, dx \, dy .$$

We will omit W in the subscript if the graphon W is clear from the context. Note that it always holds that $d(A, B) \leq |A||B|$ where $|X|$ is the measure of a set X . We would like to mention that the density between A and B is often defined in a normalized way; i.e., it is defined to be $\frac{d(A,B)}{|A||B|}$, but this is not the case in this paper.

A partition of $[0, 1]$ into measurable non-null sets U_1, \dots, U_k is said to be ε -regular if it holds that

$$\left| d(A, B) - \sum_{i,j \in [k]} \frac{d(U_i, U_j)}{|U_i||U_j|} |U_i \cap A||U_j \cap B| \right| \leq \varepsilon$$

for every two measurable subsets A and B of $[0, 1]$. The upper bound proof translates directly from graphs to graphons, and so we get that for every ε , there exists $k_0 \leq 2^{O(\varepsilon^{-2})}$ such that every graphon has an ε -regular partition with at most k_0 parts. Likewise, the example of Conlon and Fox from [11] can be used to obtain a step-graphon W_ε such that every ε -regular partition of W_ε has at least $2^{\Omega(\varepsilon^{-2})}$ parts. However, the construction is probabilistic and the description of W_ε is thus not explicit. Based on this construction, we will define an explicit graphon W_{CF}^m which has similar properties as W_ε for $\varepsilon \approx m^{-1/2}$. In fact, a W_{CF}^m -random graph of order $2^{\alpha m}$ for some α close to 0 is the graph constructed by Conlon and Fox in [11].

Fix an integer m . The graphon W_{CF}^m is a step graphon that consists of 2^m parts of equal size. Each of the parts is associated with a vector $u \in \{-1, +1\}^m$. The part of the graphon W_{CF}^m corresponding to vectors u and u' is constantly equal to $\text{trunc} \left(\frac{1}{2} + \frac{\langle u, u' \rangle}{4m^{1/2}} \right)$, where $\text{trunc}(x)$ is equal to x if $x \in [0, 1]$; it is equal to 0 if $x < 0$ and to 1 if $x > 1$. In other words, the operator $\text{trunc}(\cdot)$ replaces values smaller than 0 or larger than 1 with 0 and 1, respectively. Observe that $d([0, 1], [0, 1]) = 1/2$ by symmetry. Using the Chernoff bound, one can show that the measure of the points (x, y) with $0 < W(x, y) < 1$ is at least $1 - 2e^{-2} > 1/2$.

It would be possible to relate the proof presented in [11] to arguments on regular partitions of graphons. However, the probabilistic nature of the construction would make this technical and obfuscate some simple ideas. Because of this and to keep

the paper self-contained, we decided to present a direct proof following the lines of the reasoning given in [11].

Theorem 3. *If $m \geq 25$ and $\varepsilon < \frac{1}{2^{14}m^{1/2}}$, then every ε -regular partition of the graphon W_{CF}^m has at least $2^{m/4}$ parts.*

Proof. Fix an integer $m \geq 25$. Let V_i^- be the vertices of W_{CF}^m in the parts associated with vectors u whose i -th coordinate equals -1 . Similarly, V_i^+ are the vertices of W_{CF}^m in the parts associated with vectors u whose i -th coordinate equals $+1$.

Suppose that W_{CF}^m has an ε -regular partition U_1, \dots, U_k with $\varepsilon < 2^{-14}m^{-1/2}$ and $k < 2^{m/4}$. We say that a part U_t is *small* if $|U_t| \leq 2^{-m/3}$. Note that the sum of the measures of the small parts is at most $k \cdot 2^{-m/3} \leq 1/2$. For every $t \in [k]$, set

$$(1) \quad S_t = \sum_{i \in [m]} |U_t \cap V_i^-| \cdot |U_t \cap V_i^+|.$$

If $v \in \{-1, +1\}^m$, then the number of vectors $v' \in \{-1, +1\}^m$ such that v and v' differ in at most $m/16$ coordinates is at most $2^{m - \frac{49}{128}m} \leq 2^{2m/3-1}$ using the Chernoff bound and the fact that $m \geq 25$. Hence, for every $v \in \{-1, +1\}^m$, the measure of the vertices in the parts associated with vectors that differ from v in at most $m/16$ coordinates is at most $2^{-m/3}/2$. Consequently, if U_t is not small, then each vertex of U_t contributes to the sum (1) by at least $\frac{m}{16} (|U_t| - 2^{-m/3}/2) \geq m|U_t|/32$. We conclude that $S_t \geq |U_t|^2 m/32$ if U_t is not small.

We say that the pair $(i, t) \in [m] \times [k]$ is *useful* if $\min\{|U_t \cap V_i^-|, |U_t \cap V_i^+|\} \geq |U_t|/64$. Let $M_t, t \in [k]$, be the number of indices $i \in [m]$ such that the pair (i, t) is useful. Since each term in the sum (1) is at most $|U_t|^2/4$ and it is at most $|U_t|^2/64$ if (i, t) is not useful, it follows that $S_t \leq |U_t|^2(M_t/4 + m/64)$. We conclude that $M_t \geq m/16$ unless U_t is small (recall that $S_t \geq |U_t|^2 m/32$ if U_t is not small). Since the sum of the measures of the parts that are not small is at least $1/2$, we obtain that

$$(2) \quad \sum_{t \in [k]} M_t |U_t| \geq m/32.$$

In particular, there exists $i_0 \in [m]$ such that the sum of the measure of parts U_t such that the pair (i_0, t) is useful is at least $1/32$. Fix such an index i_0 for the rest of the proof.

Let A^- be any measurable subset of $V_{i_0}^-$ such that $|A^- \cap U_t| = |U_t|/64$ if (i_0, t) is useful, and $|A^- \cap U_t| = 0$ otherwise. Similarly, let A^+ be any measurable subset of $V_{i_0}^+$ such that $|A^+ \cap U_t| = |U_t|/64$ if (i_0, t) is useful, and $|A^+ \cap U_t| = 0$ otherwise. Such sets A^- and A^+ exist because $\min\{|U_t \cap V_{i_0}^-|, |U_t \cap V_{i_0}^+|\} \geq |U_t|/64$ for every t such that (i_0, t) is useful. Note that the sets A^- and A^+ have the same measure, and the choice of i_0 implies that this measure is at least $1/2048 = 2^{-11}$.

Let $B = V_{i_0}^-$. Since the partition U_1, \dots, U_k is ε -regular, we get that

$$\left| d(A^+B) - \sum_{i,j \in [k]} \frac{d(U_i, U_j)}{|U_i||U_j|} |U_i \cap A^+||U_j \cap B| \right| \leq \varepsilon$$

and that

$$\left| d(A^-, B) - \sum_{i,j \in [k]} \frac{d(U_i, U_j)}{|U_i||U_j|} |U_i \cap A^-||U_j \cap B| \right| \leq \varepsilon.$$

Since $|A^- \cap U_t| = |A^+ \cap U_t|$ for every $t \in [k]$, we infer that $|d(A^-, B) - d(A^+, B)| \leq 2\varepsilon < 2^{-13}m^{-1/2}$. On the other hand, the choices of A^- , A^+ , and B imply that $d(A^-, B) = (1/2 + m^{-1/2}/4)|A^-||B|$ and $d(A^+, B) = (1/2 - m^{-1/2}/4)|A^+||B|$. In particular, it holds that

$$|d(A^-, B) - d(A^+, B)| = \frac{m^{-1/2}(|A^-| + |A^+|)|B|}{4} \geq 2^{-13} \cdot m^{-1/2}.$$

This contradicts the fact that U_1, \dots, U_k is an ε -regular partition of $W_{\mathbb{C}\mathbb{F}}^m$ with $\varepsilon < 2^{-14}m^{-1/2}$ and $k < 2^{m/4}$. □

At first sight, it might seem natural to consider the limit of the sequence of the graphons $W_{\mathbb{C}\mathbb{F}}^m$, $m \in \mathbb{N}$, as a candidate for a graphon with no regular partitions with few parts. It can be shown that the sequence of $W_{\mathbb{C}\mathbb{F}}^m$, $m \in \mathbb{N}$, is convergent. However, its limit is (somewhat surprisingly) the graphon that maps every $(x, y) \in [0, 1]^2$ to $1/2$, which has an ε -regular partition with one part for every ε .

We finish this section by sketching a short argument explaining why Proposition 2 is true. The proof of the weak regularity lemma in [15] is based on iterative refinements of a partition of a graph(on), at each step doubling the number of parts and increasing the “mean square density” by at least ε^2 until the partition becomes weakly ε -regular. Suppose that there exists a graphon W and that $\varepsilon_i \rightarrow 0$ as in the proposition. We can assume that $\varepsilon_{i+1} \leq \varepsilon_i/2$ for every $i \in \mathbb{N}$. We start with a trivial partition into a single part and keep refining it until it becomes ε_1 -regular; let k_1 be the number of steps made. We then continue with refining until it becomes ε_2 -regular and let $k_2 \geq k_1$ be the total number of steps made till this point. We continue this procedure and define k_i , $i \geq 3$, in the analogous way. Setting $k_0 = 0$, we conclude that the mean square density after k_m steps is at least

$$\sum_{i=1}^m (k_i - k_{i-1})\varepsilon_i^2 > \sum_{i=1}^m k_i (\varepsilon_i^2 - \varepsilon_{i+1}^2) \geq \sum_{i=1}^m \frac{3}{4}k_i\varepsilon_i^2.$$

However, each k_i must be at least $c\varepsilon_i^{-2}$ by the assumption of the proposition (otherwise, W would have a weak ε_i -regular partition with fewer than $2^{c\varepsilon_i^{-2}}$ parts). Consequently, after $m = \lceil \frac{4}{3c} \rceil + 1$ steps, the mean square density exceeds one, which is impossible.

4. DEFINITION OF THE ŠVEJK GRAPHON

We now define the Švejk graphon W_S . An illustration of the graphon is provided in Figure 1. We start by defining a tower function $t(n) : \mathbb{N} \rightarrow \mathbb{N}$ as follows:

$$t(n) = \begin{cases} 1 & \text{if } n = 0, \text{ and} \\ 2^{t(n-1)} & \text{otherwise.} \end{cases}$$

Note that $t(0) = 1$, $t(1) = 2$, $t(2) = 2^2 = 4$, $t(3) = 2^{2^2} = 16$, $t(4) = 2^{2^{2^2}} = 65536$, etc.

The notation that we define next is summarized in Table 1. For $x \in [0, 1)$, we define $[x]_1$ to be the smallest integer k such that $x < 1 - 2^{-k}$. In particular, $[x]_1 = 1$ iff $x \in [0, 1/2)$, $[x]_1 = 2$ iff $x \in [1/2, 3/4)$, $[x]_1 = 3$ iff $x \in [3/4, 7/8)$, etc. This allows us to view the interval $[0, 1)$ as split into *segments* $[0, 1/2)$, $[1/2, 3/4)$, $[3/4, 7/8)$, etc., and $[x]_1$ is the index of the segment containing x (numbered from one). We then define $\llbracket x \rrbracket_1$ to be $(x + 2^{1-[x]_1} - 1) \cdot 2^{[x]_1}$; i.e., $\llbracket x \rrbracket_1$ is the position of x in the $[x]_1$ -th segment if the $[x]_1$ -th segment is scaled to the unit interval.

TABLE 1. The notation used in the definition of the Švejk graphon.

$[x]_1$	index of the segment $[0, 1/2), [1/2, 3/4), [3/4, 7/8)$, etc., containing x
$[x]_2$	index of the subsegment of the $[x]_1$ -th segment containing x (the segment is divided into $t([x]_1)$ subsegments)
$[x]_3$	index of the part of the $[x]_2$ -th subsegment of the $[x]_1$ -th segment containing x (the subsegment is divided into $t([x]_1)$ parts)
$[x]_{2,3}$	$[x]_3 + t([x]_1)[x]_2$
$\llbracket x \rrbracket_1$	the position of x in its segment scaled to be in $[0, 1)$
$\llbracket x \rrbracket_{1,i}^{01}$	the i -th bit of the binary representation of $\llbracket x \rrbracket_1$
$\llbracket x \rrbracket_1^{\pm 1}$	a vector in $\{\pm 1\}^{t([x]_1-1)}$ whose i -th coordinate is $2\llbracket x \rrbracket_{1,i}^{01} - 1$
$[x]_{j,i}^{01}$	the i -th bit of the binary representation of $[x]_j$
$[x]_j^{\pm 1}$	a vector in $\{\pm 1\}^{t([x]_1-1)}$ whose $(i+1)$ -th coordinate is $2[x]_{j,i}^{01} - 1$

Next, we let $[x]_2$ equal $\llbracket \llbracket x \rrbracket_1 \cdot t([x]_1) \rrbracket$. In other words, if the $[x]_1$ -th segment of $[0, 1)$ is divided into $t([x]_1)$ parts of the same length $2^{-[x]_1}/t([x]_1)$, then $[x]_2$ is the index of the part containing x if the parts are numbered from 0. We refer to these parts of the segments as *subsegments*. Analogously, we let $[x]_3$ be the index of the part containing x when the $[x]_2$ -th subsegment of the $[x]_1$ -th segment is divided into $t([x]_1)$ parts of length $2^{-[x]_1}/t([x]_1)^2$, where the parts are numbered from 0. Define $[x]_{2,3}$ to be $[x]_3 + t([x]_1)[x]_2$. Note that $[x]_{2,3}$ can also be viewed as the part containing x when the $[x]_1$ -th segment is divided into $t([x]_1)^2$ parts of length $2^{-[x]_1}/t([x]_1)^2$ and that $[x]_3$ is equal to $[x]_{2,3}$ reduced modulo $t([x]_1)$.

For $i \geq 1$, let $\llbracket x \rrbracket_{1,i}^{01}$ denote the i -th bit in the binary representation of $\llbracket x \rrbracket_1$. For example, if $\llbracket x \rrbracket_1 = 0.375 = .011$ in binary, then $\llbracket x \rrbracket_{1,1}^{01} = 0$, $\llbracket x \rrbracket_{1,2}^{01} = \llbracket x \rrbracket_{1,3}^{01} = 1$ and $\llbracket x \rrbracket_{1,i}^{01} = 0$ for $i \geq 4$. We let $\llbracket x \rrbracket_1^{\pm 1}$ denote the vector in $\{\pm 1\}^{t([x]_1-1)}$ whose i -th coordinate is equal to $2\llbracket x \rrbracket_{1,i}^{01} - 1$ (i.e., 1 is mapped to +1 and 0 is mapped to -1).

For $j \in \{2, 3\}$ and $i \geq 0$, let $[x]_{j,i}^{01}$ denote the i -th bit in the binary representation of $[x]_j$. For example, if $[x]_j = 5 = 2^0 + 2^2$, then $[x]_{j,0}^{01} = [x]_{j,2}^{01} = 1$, $[x]_{j,1}^{01} = 0$, and $[x]_{j,i}^{01} = 0$ for $i \geq 3$. We let $[x]_j^{\pm 1}$ denote the vector in $\{\pm 1\}^{t([x]_1-1)}$ whose $(i+1)$ -th coordinate is equal to $2[x]_{j,i}^{01} - 1$.

The Švejk graphon W_S has ten parts: $A, B, C, D, E, F, G, P, Q$, and R . For simplicity, we will define the graphon W_S as a function W_{13} from $[0, 13) \times [0, 13)$ to $[0, 1]$, and we set $W_S(x, y) = W_{13}(13x, 13y)$. All parts of W_{13} except for Q have measure one, and we associate each of them with the unit interval $[0, 1)$; i.e., we view the points of those parts as points in $[0, 1)$. The remaining part Q is associated with $[0, 4)$.

We will first define the values of the graphon W_{13} between the pairs of the parts not involving Q and R . The graphon W_{13} has values zero and one on $(AU \cdot \cdot \cup G \cup P)^2$ except on $C^2, E^2, B \times D$, and $D \times B$. Table 2 determines the values of W_{13} in this zero-one case. The values of W_{13} on C^2, E^2 , and $B \times D$ (by symmetry, this also determines the values on $D \times B$) are defined as follows. Note that the definition uses the graphon W_{CF}^m analyzed in Section 3, which was defined just before the statement of Theorem 3.

$$W_{13}(x, y) = \begin{cases} 2^{-2^{[x]_1-1}} & \text{if } [x]_1 = [y]_1, \text{ and} \\ 0 & \text{otherwise,} \end{cases} \quad \text{for } (x, y) \in C^2,$$

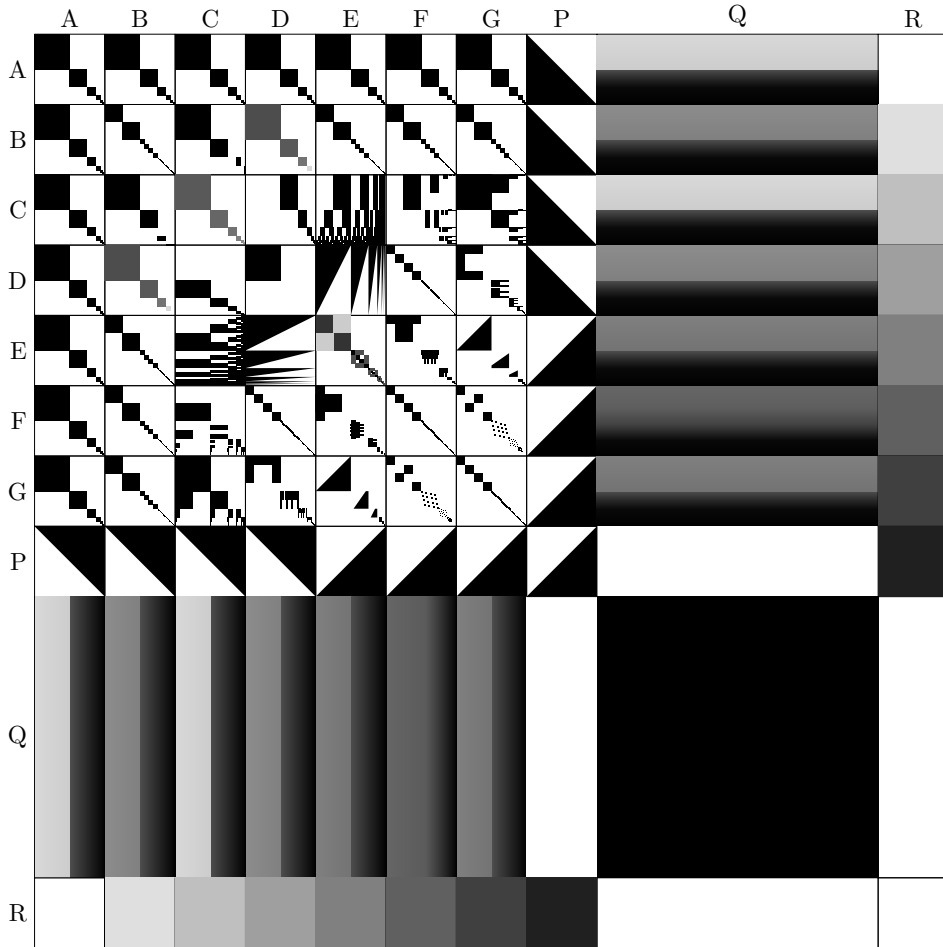

FIGURE 1. The Švejk graphon.

$$W_{13}(x, y) = \begin{cases} W_{CF}^{t([x]_1^{-1})}(\llbracket x \rrbracket_1, \llbracket y \rrbracket_1) & \text{if } [x]_1 = [y]_1, \text{ and} \\ 0 & \text{otherwise,} \end{cases} \quad \text{for } (x, y) \in E^2, \text{ and}$$

$$W_{13}(x, y) = \begin{cases} t([x]_1)^{-1} & \text{if } [x]_1 = [y]_1, \text{ and} \\ 0 & \text{otherwise,} \end{cases} \quad \text{for } (x, y) \in B \times D.$$

We have defined the values of the graphon W_{13} on $(A \cup \dots \cup G \cup P)^2$, i.e., between all pairs of its parts not involving Q and R .

The part Q is used to equalize degrees of the vertices in the parts A, \dots, G, P , i.e., to make the values

$$\frac{1}{13} \int_{[0,13)} W_{13}(x, y) \, dy$$

TABLE 2. The definition of the Švejk graphon on $(A \cup \dots \cup G \cup P)^2$ except on C^2 , E^2 , $B \times D$, and $D \times B$.

A pair (x, y) belongs to	The value of $W_{13}(x, y)$ is 1 if and only if
$A \times (A \cup B \cup \dots \cup G)$	$[x]_1 = [y]_1$
$B \times (B \cup E \cup F \cup G)$	$[x]_1 = [y]_1$ and $[x]_2 = [y]_2$
$B \times C$	$t([x]_1 - 1) = [y]_1$
$D \times C$	$[x]_1 = [y]_1 + 1$
$D \times D$	$[x]_1 = [y]_1 = 1$
$D \times G$	$[x]_1 = [y]_1$ and $\llbracket y \rrbracket_1 \leq \frac{1}{2} + \frac{\langle [x]_2^{\pm 1}, [x]_3^{\pm 1} \rangle}{4t([x]_1 - 1)^{1/2}}$
$E \times C$	$\llbracket x \rrbracket_{1, [y]_1}^{01} = 1$
$E \times D$	$y \leq 1 - \llbracket x \rrbracket_1$
$F \times C$	$[y]_1 \leq t([x]_1 - 1)$, $\llbracket x \rrbracket_{1, [y]_1}^{01} = 1$ and $\llbracket y \rrbracket_1 \leq t([x]_1)^{-1} 2^{[y]_1}$
$F \times E$	$[x]_1 = [y]_1$ and $\llbracket y \rrbracket_1 \leq \frac{1}{2} - \frac{\langle [x]_2^{\pm 1}, [x]_3^{\pm 1} \rangle}{4t([x]_1 - 1)}$
$F \times (D \cup F)$ or $G \times G$	$[x]_{2,3} = [y]_{2,3}$
$F \times G$	$[x]_3 = [y]_2$
$G \times C$	$[y]_1 \leq t([x]_1 - 1)$ and $\llbracket y \rrbracket_1 \leq t([x]_1)^{-1} 2^{[y]_1}$
$G \times E$	$[x]_1 = [y]_1$ and $1 - \llbracket x \rrbracket_1 \leq \frac{1}{2} + t([x]_1 - 1)^{1/2} (\llbracket y \rrbracket_1 - \frac{1}{2})$
$P \times (A \cup B \cup C \cup D)$	$x \leq y$
$P \times (E \cup F \cup G \cup P)$	$x \geq 1 - y$

be the same for all x from the same part; see Section 5 for further details on the degree of a vertex in a graphon. If $x \in A \cup \dots \cup G \cup P = \overline{Q \cup R}$ and $y \in Q$, then

$$W_{13}(x, y) = \frac{1}{4} \left(4 - \int_{\overline{Q \cup R}} W_{13}(x, z) \, dz \right).$$

It is straightforward to verify that $W_{13}(x, y) \in [0, 1]$ for every $(x, y) \in \overline{Q \cup R} \times Q$.

The part R distinguishes the parts by vertex degrees. If $y \in R$, then

$$W_{13}(x, y) = \begin{cases} 1/8 & \text{if } x \in B, \\ 2/8 & \text{if } x \in C, \\ 3/8 & \text{if } x \in D, \\ 4/8 & \text{if } x \in E, \\ 5/8 & \text{if } x \in F, \\ 6/8 & \text{if } x \in G, \\ 7/8 & \text{if } x \in P, \text{ and} \\ 0 & \text{otherwise.} \end{cases}$$

Finally, the graphon W_{13} is equal to 1 on $Q \times Q$.

The vertices in each of the ten parts of the Švejk graphon have the same degree (note that $W(x_1, y) = W(x_2, y)$ for any two vertices $x_1, x_2 \in Q$ and any $y \in [0, 13)$). This degree is given in Table 3. We have not computed the degree of the vertices in the part Q exactly since it is enough to establish that this degree is larger than (and thus distinct from) the degrees of the vertices in the other parts.

We finish this section by establishing that the Švejk graphon has no weak regular partitions with few parts.

TABLE 3. The degrees of the vertices in each part of the Švejk graphon.

Part	<i>A</i>	<i>B</i>	<i>C</i>	<i>D</i>	<i>E</i>	<i>F</i>	<i>G</i>	<i>P</i>	<i>Q</i>	<i>R</i>
Degree	$\frac{32}{104}$	$\frac{33}{104}$	$\frac{34}{104}$	$\frac{35}{104}$	$\frac{36}{104}$	$\frac{37}{104}$	$\frac{38}{104}$	$\frac{39}{104}$	$\geq \frac{40}{104}$	$\frac{28}{104}$

Proposition 4. *The Švejk graphon W_S has no weak ε -regular partition with fewer than $2^{t(n)/4}$ parts if $\varepsilon < \frac{1}{2^{24+2n}t(n)^{1/2}}$ and $n \geq 4$. In particular, there exists a sequence of positive reals ε_i tending to 0 such that every weak ε_i -regular partition of W_S has at least $2^{\Omega\left(\varepsilon_i^{-2}/2^{5 \log^* \varepsilon_i^{-2}}\right)}$ parts.*

Proof. The graphon W_S contains a copy of $W_{CF}^{t(n)}$ scaled by $2^{-n-1}/13$ for every $n \in \mathbb{N}$. Note that a weak ε -regular partition of W_S yields a weak $(\varepsilon 2^{-2n}/676)$ -regular partition of $W_{CF}^{t(n)}$ with fewer or the same number of parts. It follows that W_S cannot have a weak ε -regular partition with fewer than $2^{t(n)/4}$ parts for $\varepsilon < \frac{1}{676 \cdot 2^{14+2n} \cdot t(n)^{1/2}}$ and $n \geq 4$ by Theorem 3.

Setting $\varepsilon_i = \frac{1}{2^{25+2i}t(i)^{1/2}}$, we obtain the desired sequence of ε_i 's. Note that

$$\lim_{i \rightarrow \infty} \frac{\log^* \varepsilon_i^{-2}}{i} = \lim_{i \rightarrow \infty} \frac{\log^* (2^{4i+50}t(i))}{i} = 1,$$

and so $\frac{t(i)}{4} \in \Omega\left(\varepsilon_i^{-2}/2^{5 \log^* \varepsilon_i^{-2}}\right)$ as desired. □

5. CONSTRAINTS

The proof that the Švejk graphon is finitely forcible uses the notion of decorated constraints, which was introduced in [18] and further developed in [17]. We now present the notion following the lines of [17].

A *constraint* is an equality between two density expressions where a *density expression* is recursively defined as follows: a real number or a graph H are density expressions, and if D_1 and D_2 are two density expressions, then the sum $D_1 + D_2$ and the product $D_1 \cdot D_2$ are also density expressions. The value of the density expression for a graphon W is the value obtained by substituting for each graph H its density in W .

As observed in [18], if W is the unique graphon (up to weak isomorphism) that satisfies a finite set \mathcal{C} of constraints, then it is finitely forcible. In particular, W is the unique graphon with densities of subgraphs appearing in \mathcal{C} equal to their densities in W . Hence, a possible way of establishing that a graphon W is finitely forcible is providing a finite set of constraints \mathcal{C} such that the graphon W is the unique graphon up to weak isomorphism that satisfies these constraints.

If W is a graphon, then the points of $[0, 1]$ can be viewed as vertices, and we can also speak of the *degree* of a vertex $x \in [0, 1]$, defined as

$$\text{deg}_W(x) = \int_{[0,1]} W(x, y) \, dy .$$

Note that the degree is well-defined for almost every vertex of W . We will omit the subscript W when the graphon is clear from the context. A graphon W is *partitioned* if there exist $k \in \mathbb{N}$ and positive reals a_1, \dots, a_k summing to one and distinct reals d_1, \dots, d_k between 0 and 1 such that the set of vertices of W with

degree d_i (referred to as a *part* of the partitioned graphon) has measure a_i . The following lemma was proven in [18].

Lemma 5. *Let a_1, \dots, a_k be positive real numbers summing to one and let d_1, \dots, d_k be distinct reals between 0 and 1. There exists a finite set of constraints \mathcal{C} such that any graphon W satisfying \mathcal{C} is a partitioned graphon with parts of sizes a_1, \dots, a_k and degrees d_1, \dots, d_k , and any partitioned graphon with parts of sizes a_1, \dots, a_k and degrees d_1, \dots, d_k satisfies \mathcal{C} .*

We now introduce a stronger type of constraint, which was also used in [17, 18]. We will refer to the constraints introduced earlier as *ordinary constraints* if a distinction needs to be made. Suppose that W is a partitioned graphon with parts $A_i \subseteq [0, 1]$, $i \in [k]$, where the part A_i has measure a_i and it contains vertices of degrees d_i . A *decorated graph* is a graph with some vertices distinguished as *roots* and each vertex labeled with one of the parts A_1, \dots, A_k ; the roots of a decorated graph come with a fixed order. Two decorated graphs are *isomorphic* if they have the same number of roots and there exists a bijection between their vertices that is a graph isomorphism that maps roots to roots only while preserving their order and that preserves vertex labels. Two decorated graphs are *compatible* if the subgraphs induced by their roots are isomorphic (as decorated graphs). A *decorated constraint* is a constraint where all graphs appearing in the density expressions are compatible decorated graphs. Note that decorated graphs and constraints are always defined with a particular type of a partition of a graphon (i.e., names of the parts) in mind.

We now define when a graphon W satisfies a decorated constraint. Fix a decorated constraint C . Since all decorated graphs appearing in C are compatible, the roots of each of the decorated graphs appearing in C induce the same decorated graph. Let H_0 be this decorated graph and let n be the number of its vertices; note that all n vertices of H_0 are roots. The decorated constraint C is *satisfied* if the following holds for almost every n -tuple x_1, \dots, x_n of vertices of H_0 such that x_i belongs to the part that the i -th vertex of H_0 is labeled with, $W(x_i, x_j) > 0$ if x_i and x_j are adjacent in H_0 , and $W(x_i, x_j) < 1$ if they are not adjacent: the two sides of the constraint C are equal when each decorated graph H is substituted with the probability that a W -random graph with vertices corresponding to those of H is the decorated graph H conditioned on the root vertices being x_1, \dots, x_n and inducing the graph H_0 and conditioned on each of the non-root vertices chosen from a part that it is labeled with. Note that we do not allow any permutation of vertices in this definition; i.e., the requirement is stronger than saying that the W -random graph is isomorphic to the decorated graph H_0 . A possible way of satisfying the constraint C is that the measure of the n -tuples x_1, \dots, x_n of vertices of H_0 with the properties given above is zero; if this is the case, the constraint C is said to be *null-satisfied*.

Before proceeding further, let us give an example of evaluating a decorated constraint. Consider a partitioned graphon W with two parts A and B , each of measure one half, such that W is equal to one on $A \times A$, to zero on $B \times B$, and to one half on $A \times B$. The graphon W is depicted in Figure 2. Let H be a decorated graph with two roots that are adjacent and both labeled with A and two non-root vertices v_1 and v_2 that are not adjacent, both labeled with B ; v_1 is adjacent to one of the roots, and v_2 is adjacent to both roots. The decorated graph H is also depicted in Figure 2. If H appears in a decorated constraint and its two roots are from the part A of the graphon W , then it will be substituted with the probability $1/16$ when

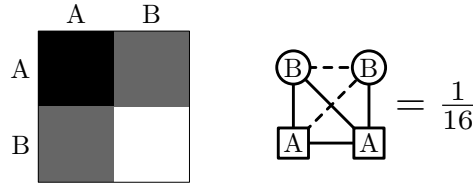

FIGURE 2. An example of evaluating a decorated constraint.

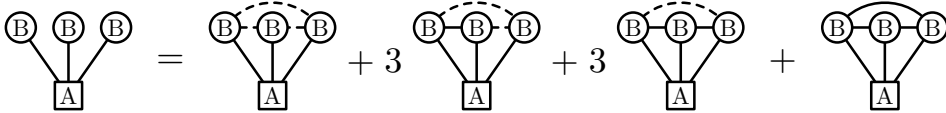

FIGURE 3. An example of interpreting a drawing of a decorated graph with some unspecified adjacencies.

evaluating the constraint with respect to W . Note that if we allowed isomorphisms of decorated graphs when evaluating decorated constraints, then this probability would be $2/16$ because the order in which the non-root vertices are chosen would be irrelevant.

The following lemma was proven in [18, Lemma 2]; also see [17, Lemma 3].

Lemma 6. *Let $k \in \mathbb{N}$, let a_1, \dots, a_k be positive real numbers summing to one, and let d_1, \dots, d_k be distinct reals between zero and one. If W is a partitioned graphon with k parts formed by vertices of degree d_i and measure a_i each, then any decorated constraint can be expressed as a single ordinary constraint; i.e., W satisfies the decorated constraint if and only if it satisfies the ordinary constraint.*

By Lemma 6, we can equivalently work with (formally stronger) decorated constraints instead of ordinary constraints.

It is useful to fix some notation for visualizing decorated constraints. We write the decorated constraints as expressions involving decorated graphs where the roots are depicted by squares and non-root vertices by circles, and each vertex is labeled with the name of the respective part of a graphon. The solid lines connecting vertices correspond to the edges and dashed lines to the non-edges. No connection between two vertices means that both edge and non-edge are allowed between the vertices; i.e., the picture should be interpreted as the sum of two graphs, one with an edge and one with a non-edge. If more than a single pair of vertices is not joined, the picture should be interpreted as the multiple sum over all non-joined pairs of vertices, which can lead to a sum containing several isomorphic copies of the same decorated graph. An example is given in Figure 3. To avoid possible ambiguity, the drawings of the subgraph induced by the roots are identical for all decorated graphs in each constraint, which makes clear which roots correspond to each other.

We remark that if we allowed isomorphisms of decorated graphs in the computation of probabilities when evaluating decorated constraints, then we would have to define the interpretation of the visualization of decorated constraints in a different way. In particular, a decorated graph with some unspecified adjacencies between its vertices would be replaced with the sum where each isomorphic copy appears with the coefficient one; i.e., the coefficients 3 would become 1 in Figure 3. In

this different setting, the visualization of the decorated constraints would actually be identical with the following single exception: the first constraint on the last line in Figure 9, where a coefficient to account for isomorphisms of the two graphs appearing in the constraint would have to be included.

We finish this section with the following lemma, which is an easy corollary of Lemma 6. In essence, it says that if a graphon W_0 can be finitely forced in its own right, then it can be forced on a single part of a partitioned graphon W without affecting the structure of the other parts.

Lemma 7. *Let W_0 be a finitely forcible graphon, let a_1, \dots, a_k be positive reals summing to one, and let d_1, \dots, d_k be distinct reals between zero and one. Then there exists a finite set \mathcal{C} of decorated constraints such that a partitioned graphon W with k parts formed by vertices of degree d_i and measure a_i each satisfies \mathcal{C} if and only if the subgraphon of W induced by the m -th part is weakly isomorphic to W_0 . In other words, if the m -th part is denoted A_m , then W satisfies \mathcal{C} if and only if there exist measure preserving maps $\varphi : [0, a_m] \rightarrow A_m$ and $\varphi_0 : [0, 1] \rightarrow [0, 1]$ such that $W(\varphi(xa_m), \varphi(ya_m)) = W_0(\varphi_0(x), \varphi_0(y))$ for almost every pair $(x, y) \in [0, 1]^2$.*

Proof. Let H_1, \dots, H_ℓ and d_1, \dots, d_ℓ be the subgraphs and their densities such that W_0 is the unique graphon (up to weak isomorphism) with these densities. The set \mathcal{C} is formed by ℓ decorated constraints: the left side of the i -th constraint contains H_i with all its vertices labelled by A_m , and the right side is equal to d_i divided by the number of automorphisms of H_i . If the subgraphon of W induced by A_m is weakly isomorphic to W_0 , then clearly these constraints are satisfied. On the other hand, since W_0 is forced by setting the densities of H_i to d_i for every $i \in [\ell]$, the converse is true as well. \square

6. FINITE FORCIBILITY OF THE ŠVEJK GRAPHON

Our final and longest section is devoted to proving that the Švejk graphon is finitely forcible. We will prove this by exhibiting a finite set of constraints that the Švejk graphon satisfies and showing that the Švejk graphon is the only graphon up to weak isomorphism that satisfies this set of constraints. By Lemma 5, there exists a finite set of constraints such that any graphon that satisfies them is a partitioned graphon with ten parts of the sizes as in the Švejk graphon and degrees of vertices in these parts as in Table 3. Hence, we can work with decorated constraints with vertices labeled by the parts A, \dots, G, P, Q , and R (see Lemma 6). We will use decorated constraints to enforce the structure of the graphon between pairs of its parts, one pair after another, often building on the structure enforced by earlier constraints. Table 4 gives references to subsections where the structure between the particular pairs of parts is forced.

Fix a graphon W_0 that satisfies all the constraints presented in this section. In particular, W_0 satisfies the constraints given by Lemma 5 and it is a partitioned graphon with ten parts of the sizes as in the Švejk graphon and degrees of vertices in these parts as in Table 3. These ten parts of W_0 will be denoted by $A_0, \dots, G_0, P_0, Q_0$, and R_0 in correspondence with the parts of the Švejk graphon. We will show that W_0 is weakly isomorphic to the Švejk graphon. To avoid cumbersome notation, we will use some symbols, in particular, \mathcal{J} , ξ , and ξ_x , in a way specific to individual subsections. The meaning will clearly be defined in the corresponding subsection, so no confusion should appear.

TABLE 4. The subsections of Section 6 where the structure of the Švejk graphon between the corresponding pairs of parts is forced.

	A	B	C	D	E	F	G	P	Q	R
A	6.2	6.2	6.2	6.2	6.2	6.2	6.2	6.1	6.9	6.9
B	6.2	6.4	6.3	6.3	6.4	6.4	6.4	6.1	6.9	6.9
C	6.2	6.3	6.3	6.2	6.5	6.5	6.5	6.1	6.9	6.9
D	6.2	6.3	6.2	6.2	6.5	6.4	6.7	6.1	6.9	6.9
E	6.2	6.4	6.5	6.5	6.8	6.7	6.6	6.1	6.9	6.9
F	6.2	6.4	6.5	6.4	6.7	6.4	6.4	6.1	6.9	6.9
G	6.2	6.4	6.5	6.7	6.6	6.4	6.4	6.1	6.9	6.9
P	6.1	6.1	6.1	6.1	6.1	6.1	6.1	6.1	6.9	6.9
Q	6.9	6.9	6.9	6.9	6.9	6.9	6.9	6.9	6.9	6.9
R	6.9	6.9	6.9	6.9	6.9	6.9	6.9	6.9	6.9	6.9

6.1. **Coordinate system.** The half-graphon W_Δ , i.e., the zero-one graphon defined by $W_\Delta(x, y) = 1$ iff $x + y \geq 1$, is finitely forcible [13]; also see [31]. By Lemma 7, there exists a finite set of decorated constraints such that W_0 satisfies these constraints if and only if the subgraphon induced by the part P_0 is weakly isomorphic to the half-graphon W_Δ . We insist that W_0 satisfy these constraints.

Let $X \in \{A, \dots, G, P\}$. We use the symbol X_0 to refer to the corresponding element of $\{A_0, \dots, G_0, P_0\}$. By the Monotone Reordering Theorem (see [29, Proposition A.19] for more details), there exist measure preserving maps $\varphi_X : X_0 \rightarrow [0, |X_0|)$ and non-decreasing functions $f_X : [0, |X_0|) \rightarrow [0, 1)$, such that

$$f_X(\varphi_X(x)) = 13 \int_{P_0} W_0(x, z) dz$$

for almost every $x \in X_0$. Since we already know that the subgraphon of W_0 induced by P is weakly isomorphic to W_Δ , we must have $W_0(x, y) = 1$ for almost every pair $(x, y) \in P_0^2$ with $f_P(\varphi_P(x)) + f_P(\varphi_P(y)) \geq 1$, $W_0(x, y) = 0$ for almost every pair $(x, y) \in P_0^2$ with $f_P(\varphi_P(x)) + f_P(\varphi_P(y)) < 1$, and $f_P(z) = 13z$ for almost every $z \in [0, 1/13)$.

Set $g_X(x) = f_X(\varphi_X(x))$ for $x \in X_0$ and $X \in \{A, \dots, G, P\}$. For completeness, let g_Q and g_R be any measurable maps from Q_0 and R_0 to $Q \cong [0, 4)$ and $R \cong [0, 1)$ such that for any measurable subset Z of $[0, 4)$ and $[0, 1)$, respectively, we have $|g_Q^{-1}(Z)| = |Z|/13$ and $|g_R^{-1}(Z)| = |Z|/13$, respectively. Each g_X can be viewed as a map from X_0 to the part X of the graphon W_{13} . The maps $g_A, \dots, g_G, g_P, g_Q$, and g_R constitute a map g from the vertices of W_0 to the vertices of W_{13} and so to those of W_S .

We will argue that the map g as a map from the vertices W_0 to the vertices of W_S is measure preserving and we will show that $W_0(x, y) = W_S(g(x), g(y))$ for almost every pair $(x, y) \in [0, 1]^2$. This will prove that the graphons W_0 and W_S are weakly isomorphic. So far, we have established that $W_0(p, p') = W_S(g(p), g(p'))$ for almost every pair $(p, p') \in P_0^2$ and that the map g is measure preserving when restricted to $P_0 \cup Q_0 \cup R_0$.

Let us consider the decorated constraints depicted in Figure 4. Let $N_X(x) = \{y \in X_0 \mid W_0(x, y) = 1\}$ for $x \in P_0$ and $X \in \{A, \dots, G\}$. The first constraint implies

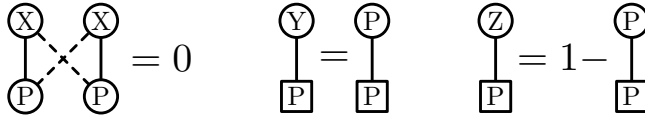

FIGURE 4. Decorated constraints used in Subsection 6.1 where $X \in \{A, B, C, D, E, F, G\}$, $Y \in \{E, F, G\}$, and $Z \in \{A, B, C, D\}$.

that the graphon W_0 is zero-one valued almost everywhere on $P_0 \times (A_0 \cup \dots \cup G_0)$ and that $N_X(x) \setminus N_X(x')$ or $N_X(x') \setminus N_X(x)$ has measure zero for almost every pair $(x, x') \in P_0^2$ and for every $X \in \{A, \dots, G\}$. The second constraint in Figure 4 implies for $Y \in \{E, F, G\}$ that the measure of $N_Y(x)$ is $g_P(x)$ for almost every $x \in P_0$. Hence, it must hold that $f_Y(y) = 13y$ for $y \in [0, 1/13)$ and $W_0(x, y) = 1$ for almost every $(x, y) \in P_0 \times Y_0$ with $g_P(x) + g_Y(y) \geq 1$. Similarly, the third constraint in Figure 4 implies for $Z \in \{A, B, C, D\}$ that the measure of $N_Z(x)$ is $1 - g_P(x)$ for almost every $x \in P_0$. Consequently, it holds that $f_Z(y) = 13y$ for $y \in [0, 1/13)$ and $W_0(x, y) = 1$ for almost every $(x, y) \in P_0 \times Z_0$ with $g_P(x) \geq g_Z(x)$. We conclude that g is a measure preserving map on the whole domain and $W_0(x, y) = W_S(g(x), g(y))$ for almost every pair $(x, y) \in P_0 \times \overline{(Q_0 \cup R_0)}$.

The values of the functions g_A, \dots, g_G can be understood to be the coordinates of the vertices in A_0, \dots, G_0 , respectively, and the coordinate of a vertex $x \in A_0 \cup \dots \cup G_0$ is

$$g_X(x) = 13 \int_{P_0} W_0(x, z) dz$$

for $X \in \{A, \dots, G\}$. This integral is easily expressible as a decorated density expression since it is just the relative edge density (degree) of x to P_0 . This view allows us to speak about segments and subsegments of the parts A_0, \dots, G_0 . The k -th segment of X_0 , $X \in \{A, \dots, G\}$, is formed by those $x \in X_0$ such that $[g_X(x)]_1 = k$. Analogously, the values $[g_X(x)]_2$ determine the subsegments.

6.2. Segmenting. We now force that the parts A_0, \dots, G_0 of W_0 are split into segments as in W_S . We also force the structure to recognize the first segment through the clique inside D_0^2 and to have the “successor” relation on the segments through the structure inside $C_0 \times D_0$. All three of these aims will be achieved by the decorated constraints given in Figure 5; the arguments follow those given in [17, 18].

The four constraints on the first line in Figure 5 force the structure on A_0^2 . The first constraint implies that there exists a set \mathcal{J} of disjoint measurable subsets of A_0 such that for almost every $x \in A_0$, there exists $J \in \mathcal{J}$ such that $W_0(x, y) = 1$ for almost every $x, y \in J$ and $W_0(x, y) = 0$ for almost every $x \in J$ and $y \notin J$. Hence, $W_0(x, y) = 1$ for almost every $(x, y) \in \bigcup_{J \in \mathcal{J}} J^2$, and $W_0(x, y) = 0$ for almost every $(x, y) \in A_0^2 \setminus \bigcup_{J \in \mathcal{J}} J^2$.

We claim that the second constraint together with the structure on $A_0 \times P_0$ yields that for every set $J \in \mathcal{J}$ there exists an open interval $J' \subseteq [0, 1)$ such that J and $g_A^{-1}(J')$ differ on a set of measure zero. Note that such an open interval J' might be empty. Since we use an argument of this kind for the first time in this paper, we give more details. If one of the (non-null) sets J did not have the property, then a random sampling of three points $x, x', x'' \in J \subseteq A_0$ with $g_A(x) < g_A(x') < g_A(x'')$

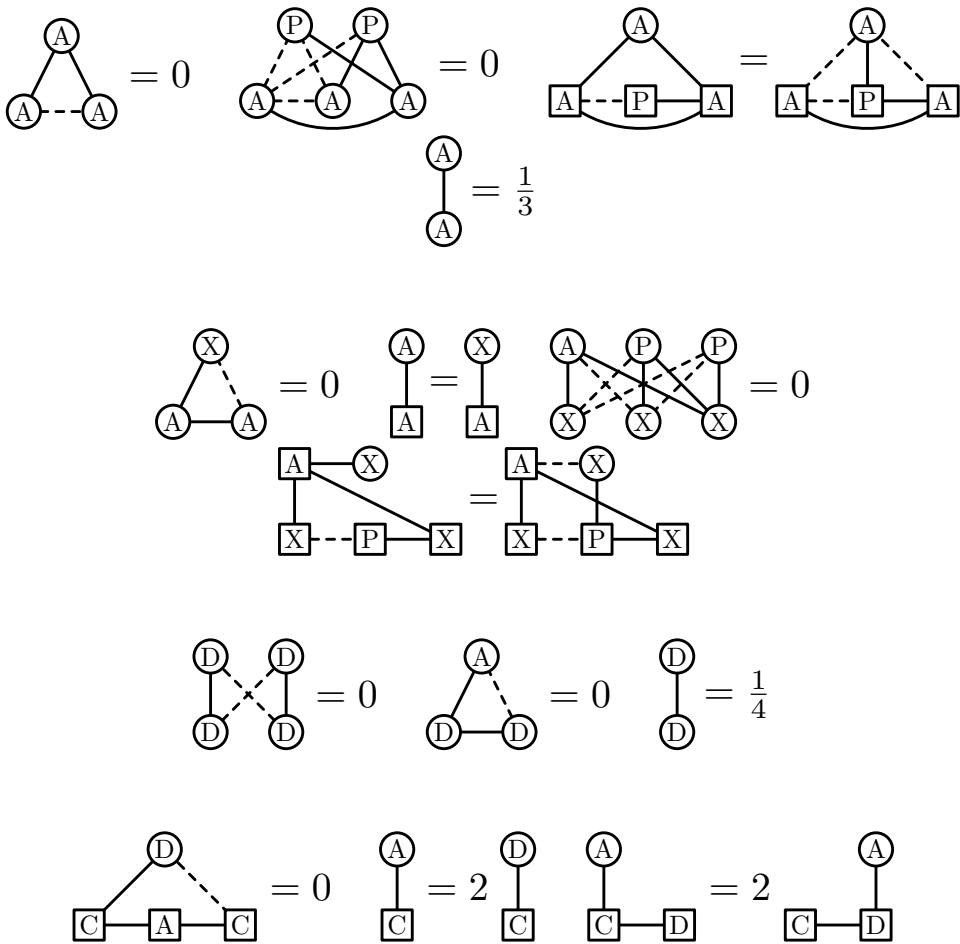

FIGURE 5. Decorated constraints used in Subsection 6.2 where $X \in \{B, C, D, E, F, G\}$.

would satisfy $W_0(x, x') = 0$ and $W_0(x, x'') = 1$ with positive probability. For such three points, the probability of sampling the additional two points from P_0 is $g_A(x') - g_A(x)$ and $g_A(x'') - g_A(x')$, and the triples of points x, x', x'' such that the differences $g_A(x') - g_A(x)$ and $g_A(x'') - g_A(x')$ would be bounded away from zero have positive measure. Let \mathcal{J}' be the set of open intervals $J' \subseteq [0, 1)$ such that $g_A^{-1}(J')$ and J differ on a set of measure zero for some $J \in \mathcal{J}$. Since the sets in \mathcal{J} are disjoint and the sets in \mathcal{J}' are open, the intervals of \mathcal{J}' are also disjoint.

The third constraint implies that if $x, x' \in g_A^{-1}(J')$ for some $J' \in \mathcal{J}'$, then the measure of the interval J' , assuming it is non-empty, and the measure of the interval $(\sup J', 1)$ are the same. Again, we provide a detailed justification since we use an argument of this kind for the first time. Almost every choice of the three roots $x \in A_0$, $x' \in P_0$, and $x'' \in A_0$ (the order follows that in the figure) satisfies that $g_A(x) < g_P(x') < g_A(x'')$ (because of the non-edge between x and x' and the edge between x' and x'') and that there exists $J' \in \mathcal{J}'$ such that $x, x'' \in g_A^{-1}(J')$

(because of the edge between x and x''). The left side is then equal to the measure of $g_A^{-1}(J')$, which is the measure of J' . The right side is equal to the measure of those $z \in A_0$ such that $z \notin g_A^{-1}(J')$ and $g_A(z) > g_P(x')$. Hence, the right side is equal to $1 - \sup J'$. Since this holds for almost every triple $x, x',$ and x'' , we conclude that the measure of each non-empty interval $J' \in \mathcal{J}'$ is $1 - \sup J'$. Consequently, each non-empty interval J' must be of the form $(1 - 2\alpha, 1 - \alpha)$ for some $\alpha \in [0, 1)$. Since the intervals of \mathcal{J}' are disjoint, there can only be a finite number of intervals to the left of each interval of \mathcal{J}' . This implies that the set \mathcal{J}' is countable.

Finally, the last constraint on the first line yields that

$$\int_{A_0^2} W(x, y) \, dx \, dy = \sum_{J' \in \mathcal{J}'} (\sup J' - \inf J')^2 = \frac{1}{3}.$$

However, this equality can hold only if the intervals contained in \mathcal{J}' are exactly the intervals $(1 - 2^{1-k}, 1 - 2^{-k}), k \in \mathbb{N}$. We conclude that $W_0(x, y)$ and $W_S(g(x), g(y))$ are equal for almost every pair $(x, y) \in A_0^2$.

We now analyze the four constraints on the second line in Figure 5. Fix $X \in \{B, \dots, G\}$. The first constraint implies that for every $J \in \mathcal{J}$, there exists $Z_J \subseteq X_0$ such that $W_0(x, y) = 1$ for almost every $(x, y) \in J \times Z_J$ and $W_0(x, y) = 0$ for almost every $(x, y) \in J \times (X_0 \setminus Z_J)$. The second constraint yields that the measure of Z_J is the same as the measure of J . The third constraint implies that there exists an open interval Z'_J such that Z_J and $g_X^{-1}(Z'_J)$ differ on a set of measure zero. Finally, the last constraint on the second line yields that each of the intervals Z'_J is of the form $(1 - 2\alpha, 1 - \alpha)$ for some $\alpha \in [0, 1)$. Since the length of Z'_J is the same as the measure of J , we conclude that if $J = g_A^{-1}((1 - 2^{1-k}, 1 - 2^{-k}))$, then $Z'_J = (1 - 2^{1-k}, 1 - 2^{-k})$. Hence, $W_0(x, y)$ and $W_S(g(x), g(y))$ are equal for almost every pair $(x, y) \in A_0 \times X_0, X \in \{B, \dots, G\}$.

Let us turn our attention to the three constraints on the third line in Figure 5. The first constraint implies that there exists a subset Z_D of D_0 such that $W_0(x, y) = 1$ for almost every $(x, y) \in Z_D^2$ and $W_0(x, y) = 0$ for almost every $(x, y) \in D_0^2 \setminus Z_D^2$. The second constraint yields that Z_D is a subset of Z_J for some $J \in \mathcal{J}$. Finally, the third constraint says that the square of the measure of Z_D is $1/4$; i.e., the measure of Z_D is $1/2$. However, this is only possible if Z_D and $g_D^{-1}((0, 1/2))$ differ on a set of measure zero. We conclude that $W_0(x, y)$ and $W_S(g(x), g(y))$ are equal for almost every pair $(x, y) \in D_0^2$.

It remains to analyze the three constraints on the last line in Figure 5. The first constraint yields that for every $k \in \mathbb{N}$, there exists $Z_k \subseteq D_0$ such that $W(x, y) = 1$ for almost every $(x, y) \in g_C^{-1}((1 - 2^{1-k}, 1 - 2^{-k})) \times Z_k$ and $W(x, y) = 0$ for almost every $(x, y) \in g_C^{-1}((1 - 2^{1-k}, 1 - 2^{-k})) \times (D_0 \setminus Z_k)$. The second constraint yields that the measure of Z_k is 2^{-k-1} , and the third constraint that Z_k is a subset of $g_D^{-1}((1 - 2^{-k}, 1 - 2^{-k-1}))$ except for a set of measure zero. Hence, Z_k and $g_D^{-1}((1 - 2^{-k}, 1 - 2^{-k-1}))$ differ on a set of measure zero, and we can conclude that $W_0(x, y)$ and $W_S(g(x), g(y))$ are equal for almost every pair $(x, y) \in C_0 \times D_0$.

6.3. Tower function. In this subsection, we will force a representation of the tower inside $B_0 \times D_0$. This is achieved using the constraints depicted in Figure 6. Before analyzing these constraints, we give an analytic observation based on [31, proof of Lemma 3.3].

Lemma 8. *Let $F : [0, 1]^2 \rightarrow [0, 1]$ be a measurable function. If*

$$\int_{[0,1]} F(x, z)F(y, z) dz = \xi$$

for almost every $(x, y) \in [0, 1]^2$, then

$$\int_{[0,1]} F(x, z)^2 dz = \xi$$

for almost every $x \in [0, 1]$.

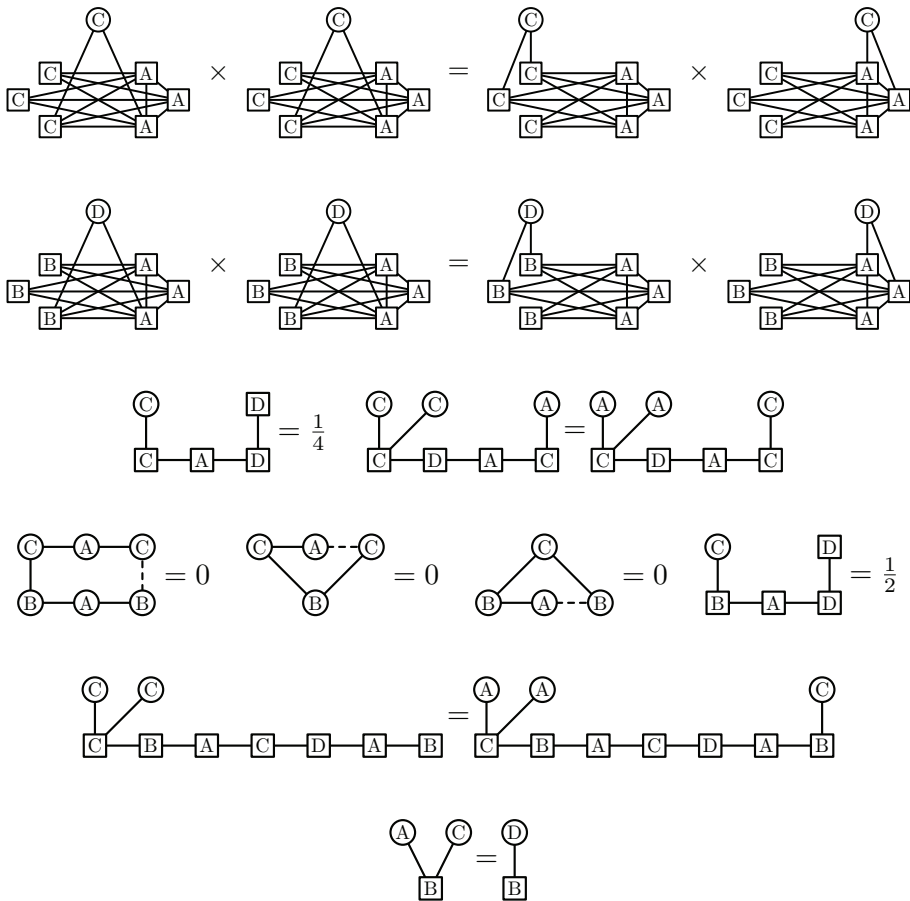

FIGURE 6. Decorated constraints used in Subsection 6.3.

The constraint on the first line in Figure 6 yields that

$$\begin{aligned} & \left(\int_{C_0} W_0(x, z)W_0(y, z) \, dz \right)^2 \\ &= \left(\int_{C_0} W_0(x', z)W_0(x'', z) \, dz \right) \left(\int_{C_0} W_0(y', z)W_0(y'', z) \, dz \right) \end{aligned}$$

for almost every $x, x', x'' \in C_0$ and $y, y', y'' \in A_0$ all in the same segment (this is implied by the presence of the edges between the roots). By Lemma 8, we get that

$$\left(\int_{C_0} W_0(x, z)W_0(y, z) \, dz \right)^2 = \left(\int_{C_0} W_0(x', z)^2 \, dz \right) \left(\int_{C_0} W_0(y', z)^2 \, dz \right)$$

for almost every $x, x' \in C_0$ and $y, y' \in A_0$ such that $[g_C(x)]_1 = [g_A(y)]_1$. Since the equality holds for almost every $x, x' \in C_0$ and $y, y' \in A_0$, it actually holds that

$$\left(\int_{C_0} W_0(x, z)W_0(y, z) \, dz \right)^2 = \left(\int_{C_0} W_0(x, z)^2 \, dz \right) \left(\int_{C_0} W_0(y, z)^2 \, dz \right)$$

for almost every $x \in C_0$ and $y \in A_0$ such that $[g_C(x)]_1 = [g_A(y)]_1$. The Cauchy-Schwarz Inequality yields that for every $k \in \mathbb{N}$ there exists $\xi_k \in \mathbb{R}$ such that $W_0(x, z) = \xi_k \cdot W_0(y, z)$ for almost every $x \in C_0, y \in A_0$, and $z \in C_0$ with $[g_C(x)]_1 = [g_A(y)]_1 = k$. Hence, $W_0(x, z) = \xi_k$ for almost every $x \in C_0$ and $z \in C_0$ with $[g_C(x)]_1 = [g_C(z)]_1 = k$ and $W_0(x, z) = 0$ for almost every $x \in C_0$ and $z \in C_0$ with $[g_C(x)]_1 \neq [g_C(z)]_1$. Along the same lines, the constraint on the second line implies that for every $k \in \mathbb{N}$ there exists $\xi'_k \in \mathbb{R}$ such that $W_0(x, z) = \xi'_k \cdot W_0(y, z)$ for almost every $x \in B_0, y \in A_0$, and $z \in D_0$ with $[g_B(x)]_1 = [g_A(y)]_1 = k$. Consequently, $W_0(x, z) = \xi'_k$ for almost every $x \in D_0$ and $z \in B_0$ with $[g_D(x)]_1 = [g_B(z)]_1 = k$ and $W_0(x, z) = 0$ for almost every $x \in D_0$ and $z \in B_0$ with $[g_D(x)]_1 \neq [g_B(z)]_1$.

Almost every choice of the roots in the first constraint on the third line satisfies that all the roots belong to the same segment and this segment must be the first segment because of the edge between the two roots from D_0 . Hence, this constraint implies that $\xi_1 |g_C^{-1}((0, 1/2))| = 1/4$, i.e., $\xi_1 = 1/2$ as desired.

Let us now look at the second constraint. Almost every choice of the roots satisfies that if the right root from C_0 is in the k -th segment, then the roots from A_0 and D_0 are also in the k -th segment and the left root from C_0 is in the $(k - 1)$ -th segment. Since for every k the choice of such roots has positive probability, the constraint implies that the following holds for every $k \in \mathbb{N}$:

$$\begin{aligned} & (\xi_k |g_C^{-1}((1 - 2^{-k+1}, 1 - 2^{-k}))|)^2 |g_A^{-1}((1 - 2^{-k}, 1 - 2^{-k-1}))| \\ &= (|g_A^{-1}((1 - 2^{-k+1}, 1 - 2^{-k}))|)^2 \xi_{k+1} |g_C^{-1}((1 - 2^{-k}, 1 - 2^{-k-1}))|. \end{aligned}$$

Hence, it holds that $\xi_{k+1} = \xi_k^2 = 2^{-2^{k-1}}$. We conclude that $W_0(x, y)$ and $W_S(g(x), g(y))$ are equal for almost every pair $(x, y) \in C_0 \times C_0$.

The first three constraints on the fourth line in Figure 6 yield that for every $k \in \mathbb{N}$ either $W(x, y) = 0$ for almost every $x \in B_0$ in the k -th segment and almost every $y \in C_0$ or there exists m_k such that $W(x, y) = 1$ for almost every $x \in B_0$ in

the k -th segment and almost every $y \in C_0$ in the m_k -th segment and $W(x, y) = 0$ for almost every $y \in C_0$ not in the m_k -th segment. The last constraint on the fourth line yields that $m_1 = 1$.

We now show that the constraint on the fifth line implies that m_k exists and $m_k = t(k-1)$ for every $k \in \mathbb{N}$. For almost every choice of the roots in the constraint on the fifth line, if the right root from B_0 belongs to the k -th segment, the left root from B_0 belongs to the $(k-1)$ -th segment and the left root from C_0 belongs to the m_{k-1} -th segment. We derive that this constraint implies that

$$\left(2^{-2^{m_{k-1}-1}} \cdot 2^{-m_{k-1}}\right)^2 = \left(2^{-m_{k-1}}\right)^2 \cdot 2^{-m_k} .$$

We conclude that $m_k = 2^{m_{k-1}}$ and so $m_k = t(k-1)$. Consequently, $W_0(x, y)$ and $W_S(g(x), g(y))$ are equal for almost every pair $(x, y) \in B_0 \times C_0$.

The constraint on the last line in Figure 6 yields by considering a choice of the root in the k -th segment of B_0 that

$$2^{-k} \cdot 2^{-m_k} = \xi'_k \cdot 2^{-k} .$$

We conclude that $\xi'_k = 2^{-m_k} = 2^{-t(k-1)} = t(k)^{-1}$. Hence, $W_0(x, y)$ and $W_S(g(x), g(y))$ are equal for almost every pair $(x, y) \in B_0 \times D_0$.

6.4. Subsegmenting. We now force the parts of the graphon that further structure the segments, e.g., provide the structure of subsegments; these are the parts $B_0 \times (B_0 \cup E_0 \cup F_0 \cup G_0)$, $F_0 \times (D_0 \cup F_0 \cup G_0)$, and G_0^2 . Some of the arguments are analogous to those presented earlier in Subsection 6.2. In analogy to Subsection 6.2, the first two constraints in Figure 7 for $X = B$ yield that there exists a set \mathcal{J} of disjoint open subintervals of $[0, 1)$ such that $W_0(x, y) = 1$ for almost every $(x, y) \in g_B^{-1}(J)^2$ for some $J \in \mathcal{J}$ and $W_0(x, y) = 0$ for almost all other pairs $(x, y) \in B_0^2$. The third constraint implies that every set $g_B^{-1}(J)$ is a subset of $g_A^{-1}((1 - 2^{-k+1}, 1 - 2^{-k}))$ except for a set of measure zero for some $k \in \mathbb{N}$. Hence, each interval $J \in \mathcal{J}$ is a subinterval of $(1 - 2^{-k+1}, 1 - 2^{-k})$ for some $k \in \mathbb{N}$. The fourth constraint with $X = B$ yields that the length of each interval J is $2^{-k}t(k)^{-1}$. Finally, the first constraint on the second line can hold only if each interval $(1 - 2^{-k+1}, 1 - 2^{-k})$ contains $t(k)$ such intervals J . We conclude that $W_0(x, y)$ and $W_S(g(x), g(y))$ are equal for almost every pair $(x, y) \in B_0^2$.

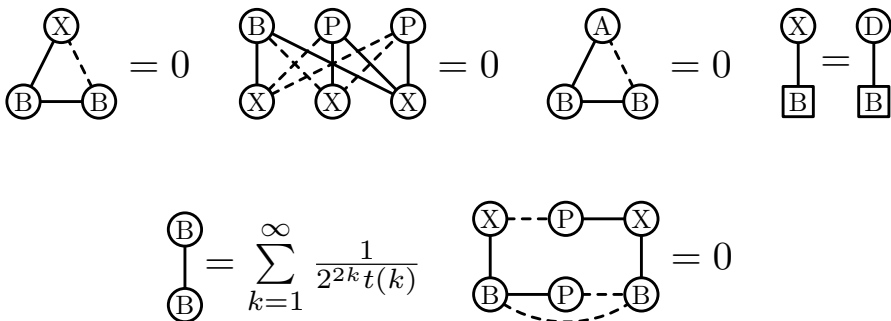

FIGURE 7. The first set of decorated constraints used in Subsection 6.4 where $X \in \{B, E, F, G\}$.

For $X \in \{E, F, G\}$, the first, second, and fourth constraints on the first line yield that for each $J \in \mathcal{J}$ there exists an open interval J' of the same length as J such that $W_0(x, y) = 1$ for almost every $(x, y) \in J \times J'$ and $W_0(x, y) = 0$ for almost every $(x, y) \in J \times (X_0 \setminus J')$. The last constraint on the second line in Figure 7 gives that the intervals J' follow in the same order as the intervals J . Hence, $W_0(x, y)$ and $W_S(g(x), g(y))$ are equal for almost every pair $(x, y) \in B_0 \times (E_0 \cup F_0 \cup G_0)$.

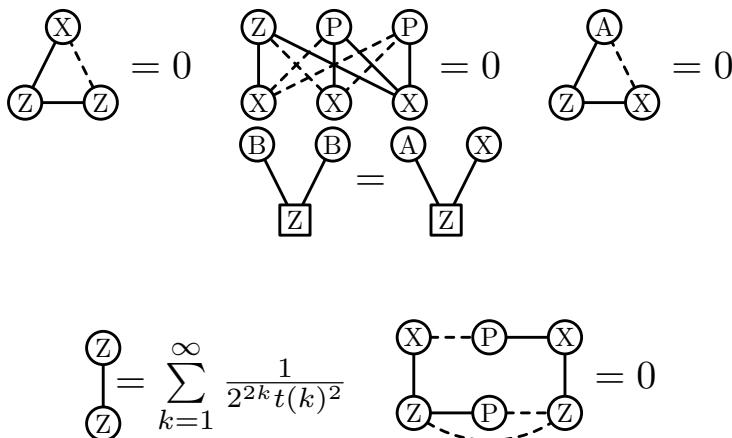

FIGURE 8. The second set of decorated constraints used in Subsection 6.4 where $(Z, X) \in \{(F, F), (F, D), (G, G)\}$.

The set of constraints in Figure 8 is analogous to those in Figure 7. The main difference is the fourth constraint, which forces that if an interval J from the set \mathcal{J}' corresponding to F_0^2 or G_0^2 is a subinterval of an interval $(1 - 2^{-k+1}, 1 - 2^{-k})$, then $(2^{-k}t(k)^{-1})^2 = 2^{-k} \cdot |J|$. Hence, the length of such an interval J must be $2^{-k}t(k)^{-2}$. The first constraint on the second line then forces that the interval $(1 - 2^{-k+1}, 1 - 2^{-k})$ must contain $t(k)^2$ such intervals J and the order of the corresponding pairs of intervals is forced by the last constraint. We can now conclude that $W_0(x, y)$ and $W_S(g(x), g(y))$ are equal for almost every pair $(x, y) \in F_0^2 \cup G_0^2 \cup (F_0 \times D_0)$.

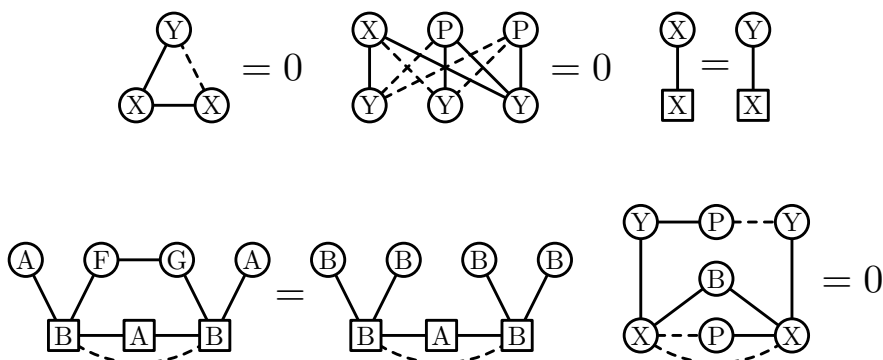

FIGURE 9. The third set of decorated constraints used in Subsection 6.4 where $(X, Y) \in \{(F, G), (G, F)\}$.

We now analyze the constraints from Figure 9. As in the previous cases, the three constraints on the first line force that each interval $(1 - 2^{-k+1}, 1 - 2^{-k})$, $k \in \mathbb{N}$, contains disjoint open intervals $I_1, \dots, I_{t(k)^2}$ and $J_1, \dots, J_{t(k)^2}$, each of length $2^{-k}t(k)^{-2}$, such that $W_0(x, y) = 1$ for almost every $(x, y) \in g_F^{-1}(I_i) \times g_F^{-1}(J_i)$ and $W_0(x, y) = 0$ for almost every $(x, y) \in g_F^{-1}(I_i) \times (F_0 \setminus g_F^{-1}(J_i))$.

Fix a choice of the roots in the first constraint on the second line in Figure 9; in almost every choice of the roots, all three roots belong to the same segment. Suppose that they belong to the k -th segment. The right side is equal to $(2^{-k}t(k)^{-1})^4$ for almost all choices of the roots (since the structure of B_0^2 has already been forced), and the left side is equal to $2^{-2k} \cdot (2^{-k}t(k)^{-2})^2$ multiplied by the number of choices of I_i and J_i such that I_i is contained in the subsegment of the left root and J_i in the subsegment of the right root. Since the left side and the right side must be equal for almost all choices of the roots, we conclude that for any pair of subsegments S and S' of the k -th segment there exists a unique index i such that I_i is contained in S and J_i in S' . The last constraint in Figure 9 enforces that for any fixed subsegment S of the k -th segment and any two subsegments S' and S'' such that S' precedes S'' , the pairs $I_i \times J_i \subseteq S \times S'$ and $I_{i'} \times J_{i'} \subseteq S \times S''$ satisfy that the interval I_i precedes the interval $I_{i'}$. This implies that $W_0(x, y)$ and $W_S(g(x), g(y))$ are equal for almost every pair $(x, y) \in F_0 \times G_0$.

6.5. Binary expansions. In this section, we force the structure of the graphon inside $E_0 \times D_0$, $E_0 \times C_0$, $G_0 \times C_0$, and $F_0 \times C_0$. This will be achieved using the constraints depicted in Figure 10.

The first constraint on the first line in the figure causes that for almost every $x \in E_0$, there exists ξ_x such that $W_0(x, y) = 1$ for almost every $y \in D_0$ with $g_D(y) \leq \xi_x$ and $W_0(x, y) = 0$ for almost every $y \in D_0$ with $g_D(y) > \xi_x$. The second constraint on the line causes that for almost every $x \in E_0$, it holds that $2^{-[g_E(x)]_1} \xi_x = 1 - 2^{-[g_E(x)]_1} - g_E(x)$. It follows that

$$\xi_x = \frac{1 - 2^{-[g_E(x)]_1} - g_E(x)}{2^{-[g_E(x)]_1}} = 1 - [g_E(x)]_1$$

for almost every $x \in E_0$. We conclude that $W_0(x, y)$ and $W_S(g(x), g(y))$ are equal for almost every pair $(x, y) \in E_0 \times D_0$.

The first constraint on the second line forces that W_0 is almost everywhere 0 or almost everywhere 1 on each product of a subsegment of E_0 and a segment of C_0 . Fix a segment S_E of E_0 . The second constraint forces that for almost every $y \in C_0$ the measure of $x \in S_E$ such that $W_0(x, y) = 1$ is exactly half of the measure of S_E . Since the measure of $y \in C_0$ such that $W_0(x, y) = 1$ is $1 - \xi_x = [g_E(x)]_1$ for almost every $x \in E_0$ because of the third constraint on the second line, the choice of the segments and subsegments where W_0 is one almost everywhere is unique. So, we get that $W_0(x, y)$ and $W_S(g(x), g(y))$ are equal for almost every pair $(x, y) \in E_0 \times C_0$.

The first constraint on the third line implies that for almost every $x \in G_0$ there exist $\xi_{x,k}$, $k \in \mathbb{N}$, such that $W_0(x, y) = 1$ for almost every y with $[g_C(y)]_1 = k$ and $[g_C(y)]_1 \leq \xi_{x,k}$ and $W_0(x, y) = 0$ for almost every other $y \in C_0$. Consider a possible choice of the roots in the second constraint on the third line. For almost every such choice of the roots, if the leftmost root from A_0 lies in the k -th segment, then the middle root from A_0 is in the $t(k - 1)$ -th segment (because of the already enforced structure of W_0 on $B_0 \times C_0$ in particular), and the rightmost root from A_0 is in the ℓ -th segment where $\ell \leq t(k - 1)$. The left side of the constraint is

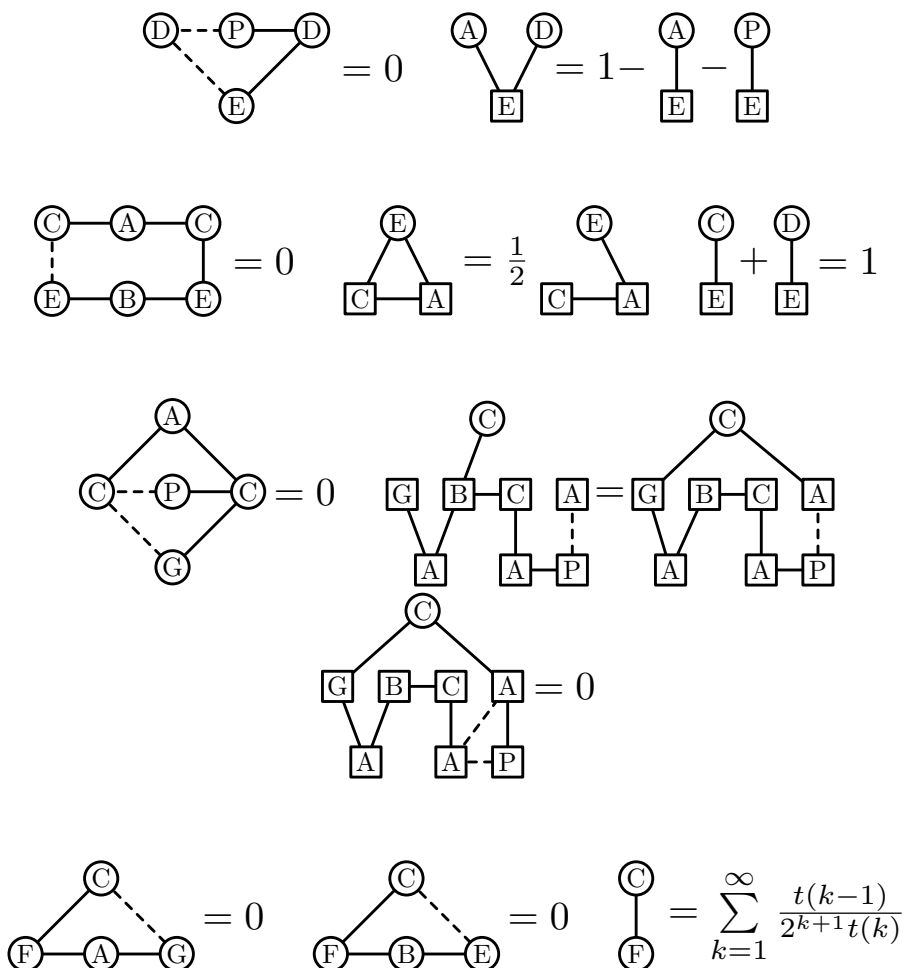

FIGURE 10. The decorated constraints used in Subsection 6.5.

equal to $2^{-t(k-1)} = t(k)^{-1}$. The right side of the constraint is equal to $\xi_{x,\ell} 2^{-\ell}$. This implies that $\xi_{x,\ell} = 2^\ell / t(k)$ for almost every x from the k -th segment of G_0 and $\ell \leq t(k-1)$. Finally, almost every choice of the roots in the last constraint on the third line satisfies that if the leftmost root from A_0 lies in the k -th segment, then the middle root from A_0 is in the $t(k-1)$ -th segment and the rightmost root from A_0 is in the ℓ -th segment where $\ell > t(k-1)$. Hence, $\xi_{x,\ell} = 0$ for almost every x from the k -th segment of G_0 and $\ell > t(k-1)$. We conclude that $W_0(x, y)$ and $W_S(g(x), g(y))$ are equal for almost every pair $(x, y) \in G_0 \times C_0$.

The first constraint on the fourth line implies that for almost every $y \in C_0$, if the measure of x with $W_0(x, y) > 0$ from the k -th segment of F_0 is positive, then $W_0(x, y) = 1$ for almost every x from the k -th segment of G_0 . Analogously, the second constraint yields that for almost every $y \in C_0$, if the measure of x with $W_0(x, y) > 0$ from a certain subsegment of F_0 is positive, then $W_0(x, y) = 1$ for almost every x from the corresponding subsegment of G_0 . Consequently, $W_0(x, y) = 0$ for almost every pair $(x, y) \in F_0 \times C_0$ such that $W_S(g(x), g(y)) = 0$. Since the last

constraint implies that the integral of W_0 over $F_0 \times C_0$ is the same as the integral of W_S over $F \times C$, it holds that $W_0(x, y)$ and $W_S(g(x), g(y))$ are equal for almost every pair $(x, y) \in F_0 \times C_0$.

6.6. Linear transformation. In this subsection, we focus on the pair G_0 and E_0 of the parts. The first constraint in Figure 11 yields that $W_0(x, y) = 0$ for almost every $(x, y) \in G_0 \times E_0$ such that the segments of $[g_G(x)]_1 \neq [g_E(y)]_1$; i.e., the segments of x and y are different. The second constraint implies that for almost every $x \in G_0$ there exists ξ_x such that $W_0(x, y) = 1$ for almost every $y \in E_0$ such that $[g_G(x)]_1 = [g_E(y)]_1$ and $\llbracket g_E(y) \rrbracket_1 \geq \xi_x$ and $W_0(x, y) = 0$ for almost every $y \in E_0$ such that $[g_G(x)]_1 = [g_E(y)]_1$ and $\llbracket g_E(y) \rrbracket_1 < \xi_x$. The third constraint implies that almost every pair of x and x' from the same segment of G_0 such that $g_G(x) < g_G(x')$ satisfies that $\xi_x \geq \xi_{x'}$. In order to show that $W_0(x, y)$ and $W_S(g(x), g(y))$ are equal for almost every pair $(x, y) \in G_0 \times E_0$, it is enough to show that

$$(3) \quad \xi_x = \frac{1}{2} + t([g_G(x)]_1 - 1)^{1/2} \left(\frac{1}{2} - \llbracket g_G(x) \rrbracket_1 \right)$$

for almost every $x \in G_0$.

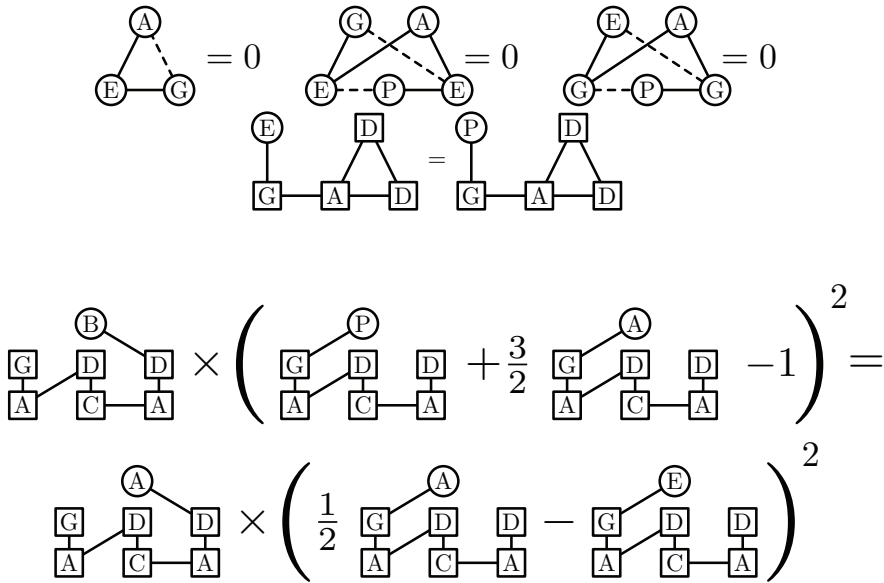

FIGURE 11. The decorated constraints used in Subsection 6.6. Note that one of the constraints is on both the second and third lines.

Almost every choice of the roots in the last constraint on the first line in Figure 11 satisfies that the root from G is from the first segment. Hence, this constraint implies that almost every $x \in G_0$ with $[g_G(x)]_1 = 1$ satisfies that $\frac{1-\xi_x}{2} = g_G(x)$. Since $t(0) = 1$ and $\llbracket g_G(x) \rrbracket_1 = 2g_G(x)$ for such $x \in G_0$, we obtain that (3) holds for almost every x from the first segment of G_0 .

We now analyze the constraint on the second and third lines in Figure 11. Note that almost every choice of the roots satisfies that if the left root from A is in the k -th segment, then the root from G is also in the k -th segment and the right root from A and the right root from D are in the $(k - 1)$ -th segment. In particular, $k \geq 2$ for almost every choice of the roots. Rewriting the densities using the already established structure of the graphon, we obtain that almost every $x \in G_0$ with $[g_G(x)]_1 = k \geq 2$ satisfies that

$$\frac{2^{-(k-1)}}{t(k-1)} \left(g_G(x) + \frac{3}{2} \cdot 2^{-k} - 1 \right)^2 = 2^{-(k-1)} \left(\frac{1}{2} \cdot 2^{-k} - (1 - \xi_x)2^{-k} \right)^2.$$

Since it holds that $\llbracket g_G(x) \rrbracket_1 = 2^k \cdot (g_G(x) - 1 + 2^{-(k-1)})$, we can rewrite the equation to obtain

$$\frac{2^{-(k-1)}}{t(k-1)} \left(2^{-k} \llbracket g_G(x) \rrbracket_1 - \frac{1}{2} \cdot 2^{-k} \right)^2 = 2^{-(k-1)} \left(\frac{1}{2} \cdot 2^{-k} - (1 - \xi_x)2^{-k} \right)^2,$$

which can be transformed to

$$\left(\llbracket g_G(x) \rrbracket_1 - \frac{1}{2} \right)^2 = t(k-1) \left(\xi_x - \frac{1}{2} \right)^2.$$

This implies that ξ_x is equal to

$$\frac{1}{2} + t(\llbracket g_G(x) \rrbracket_1 - 1)^{1/2} \left(\frac{1}{2} - \llbracket g_G(x) \rrbracket_1 \right) \text{ or } \frac{1}{2} - t(\llbracket g_G(x) \rrbracket_1 - 1)^{1/2} \left(\frac{1}{2} - \llbracket g_G(x) \rrbracket_1 \right)$$

for almost every $x \in G_0$ not contained in the first segment of G_0 . Recall that almost every pair of x and x' from the same segment of G_0 such that $g_G(x) < g_G(x')$, which is equivalent to $\llbracket g_G(x) \rrbracket_1 < \llbracket g_G(x') \rrbracket_1$, satisfies that $\xi_x \geq \xi_{x'}$. This implies that the latter of the two options for the values ξ_x holds for almost no $x \in G_0$, and thus (3) also holds for almost every $x \in G_0$ not contained in the first segment of G_0 . We conclude that $W_0(x, y)$ and $W_S(g(x), g(y))$ are equal for almost every pair $(x, y) \in G_0 \times E_0$.

6.7. Dot product. We now enforce the structure inside the pairs $F_0 \times E_0$ and $D_0 \times G_0$. The first constraint in Figure 12 yields that $W_0(x, y) = 0$ for almost every $(x, y) \in F_0 \times E_0$ with $[g_F(x)]_1 \neq [g_E(y)]_1$; i.e., the segments of x and y are different. The second constraint implies that for almost every $x \in F_0$ there exists ξ_x such that $W_0(x, y) = 1$ for almost every $y \in E_0$ with $[g_F(x)]_1 = [g_E(y)]_1$ and $\llbracket g_E(y) \rrbracket_1 \leq \xi_x$ and $W_0(x, y) = 0$ for almost every $y \in E_0$ with $[g_F(x)]_1 = [g_E(y)]_1$ and $\llbracket g_E(y) \rrbracket_1 > \xi_x$. In order to show that $W_0(x, y)$ and $W_S(g(x), g(y))$ are equal for almost every pair $(x, y) \in F_0 \times E_0$, it is enough to show that

$$(4) \quad \xi_x = \frac{1}{2} - \frac{\langle [g_F(x)]_2^{\pm 1}, [g_F(x)]_3^{\pm 1} \rangle}{4t(\llbracket g_F(x) \rrbracket_1 - 1)}$$

for almost every $x \in F_0$.

Let x and x' be two elements of F_0 from the same segment, say, the k -th segment. By the structure on $F_0 \times C_0$, the measure of $y \in C_0$ such that either $W_0(x, y) = 1$ and $W_0(x', y) = 0$ or $W_0(x, y) = 0$ and $W_0(x', y) = 1$ is equal to the number of different pairs of coordinates in $\llbracket g_F(x) \rrbracket_1^{\pm 1}$ and $\llbracket g_F(x') \rrbracket_1^{\pm 1}$ multiplied by $t(k)^{-1}$ for almost any pair x and x' . This measure can be rewritten as

$$(5) \quad \frac{t(k-1) - \langle \llbracket g_F(x) \rrbracket_1^{\pm 1}, \llbracket g_F(x') \rrbracket_1^{\pm 1} \rangle}{2t(k)}.$$

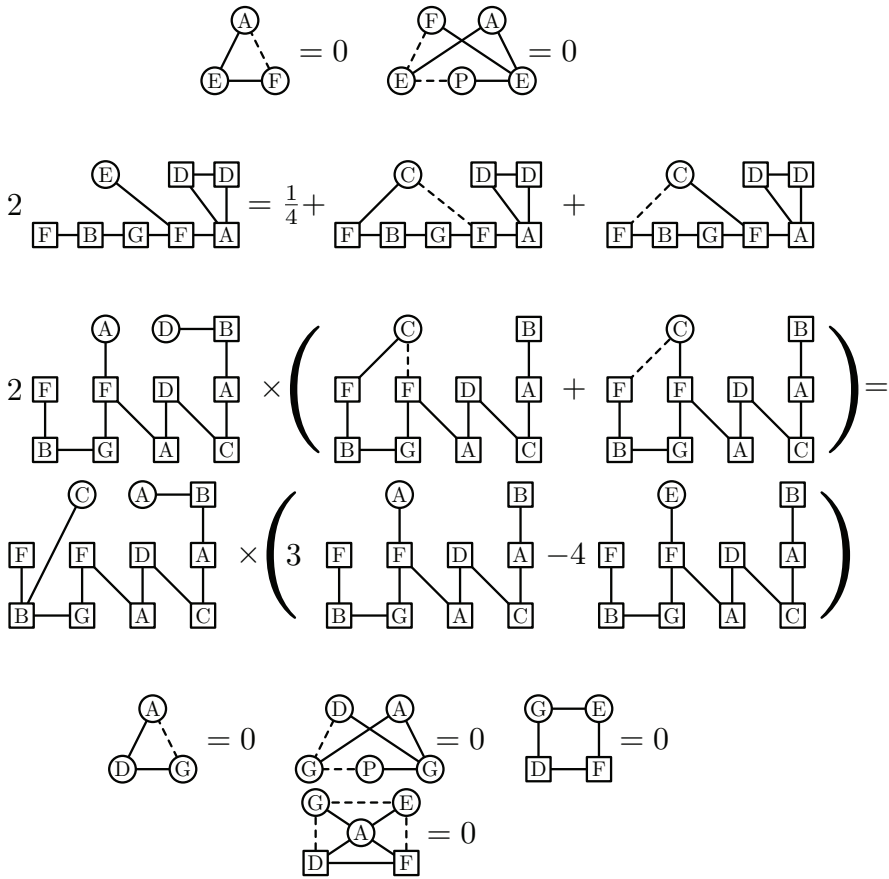

FIGURE 12. The set of decorated constraints used in Subsection 6.7. Note that one of the constraints is on both the third and fourth lines.

Consider now the constraint on the second line in Figure 12. For almost every choice of the roots, their segments are the same, and so they all belong to the first segment of their parts (because of the edge between the two roots from D_0). Let x be the right root that belongs to F_0 and x' the left one. Because of the already enforced structure of the graphon, the subsegment of x' is $[g_F(x)]_3$ in almost every choice of the roots. Using (5) with $t(0) = 1$ and $t(1) = 2$, we derive that it holds for almost every $x \in F_0$ that belongs to the first segment that

$$2 \cdot \frac{\xi_x}{2} = \frac{1}{4} + \frac{1 - \langle [g_F(x)]_2^{\pm 1}, [g_F(x)]_3^{\pm 1} \rangle}{4}.$$

We conclude that the equation (4) holds for almost every $x \in F_0$ from the first segment.

We now consider the constraint on the third and fourth lines in Figure 12. In almost every choice of the roots, the index of the segment of the two roots from F_0 is one larger than that of the segment of the root from A_0 adjacent to the root from C_0 . Also note that for almost every $x \in F_0$ that does not belong to the first

segment, there is a set of positive measure of possible choices of the roots. Let x be the right root from F_0 , x' the left one, and k the common index of their segment. The constraint implies for almost every choice of the roots that

$$2 \cdot \frac{2^{-k} \cdot 2^{-(k-1)}}{t(k-1)} \cdot \frac{t(k-1) - \langle \llbracket g_F(x) \rrbracket_1^{\pm 1}, \llbracket g_F(x') \rrbracket_1^{\pm 1} \rangle}{2t(k)} = \frac{2^{-(k-1)}}{2^{t(k-1)}} (3 \cdot 2^{-k} - 4\xi_x \cdot 2^{-k}).$$

This expression readily transforms to

$$1 - \frac{\langle \llbracket g_F(x) \rrbracket_1^{\pm 1}, \llbracket g_F(x') \rrbracket_1^{\pm 1} \rangle}{t(k-1)} = 3 - 4\xi_x.$$

Since we can choose the roots for almost every $x \in F_0$ that does not belong to the first segment with positive probability, almost every such $x \in F_0$ satisfies (4). We conclude that $W_0(x, y)$ and $W_S(g(x), g(y))$ are equal for almost every pair $(x, y) \in F_0 \times E_0$.

In the analogy to the first two constraints on the first last in Figure 12, the first two constraints on the last line in the figure yield that for almost every $z \in D_0$, there exists λ_z such that $W_0(z, y) = 1$ for almost every $y \in G_0$ with $[g_D(z)]_1 = [g_G(y)]_1$ and $\llbracket g_G(y) \rrbracket_1 \leq \lambda_z$ and $W_0(z, y) = 0$ for almost every $y \in G_0$ with $[g_D(z)]_1 \neq [g_G(y)]_1$ or $\llbracket g_G(y) \rrbracket_1 > \lambda_z$. We now consider the last two constraints on the last line in Figure 12. Fix a choice of roots $x \in F_0$ and $z \in D_0$. Almost every such choice of roots satisfies $[g_F(x)]_{2,3} = [g_D(z)]_{2,3}$, which implies that $[g_F(x)]_1 = [g_D(z)]_1$. The last but one constraint yields that $W_0(y, y') = 0$ for almost every $y \in E_0, y' \in G_0, [g_E(y)]_1 = [g_F(x)]_1, [g_G(y)]_1 = [g_D(z)]_1, \llbracket g_E(y) \rrbracket_1 \leq \xi_x$, and $\llbracket g_G(y') \rrbracket_1 \leq \lambda_z$. Similarly, the last constraint yields that $W_0(y, y') = 1$ for almost every $y \in E_0, y' \in G_0, [g_E(y)]_1 = [g_F(x)]_1, [g_G(y)]_1 = [g_D(z)]_1, \llbracket g_E(y) \rrbracket_1 > \xi_x$, and $\llbracket g_G(y') \rrbracket_1 > \lambda_z$. The structure of the graphon W_0 on $E_0 \times G_0$ implies that

$$(6) \quad \lambda_z = \text{trunc} \left(t(k-1)^{1/2} \left(\frac{1}{2} - \xi_x \right) + \frac{1}{2} \right)$$

for almost every pair of $x \in F_0$ and $z \in D_0$ such that $[g_F(x)]_{2,3} = [g_D(z)]_{2,3}$ and $[g_F(x)]_1 = [g_D(z)]_1 = k$. The expression (4) can be rewritten (for a particular choice of x and z) as

$$(7) \quad \xi_x = \frac{1}{2} - \frac{\langle [g_D(z)]_2^{\pm 1}, [g_D(z)]_3^{\pm 1} \rangle}{4t(k-1)}.$$

We get by substituting (7) in (6) that

$$\lambda_z = \text{trunc} \left(\frac{1}{2} + \frac{\langle [g_D(z)]_2^{\pm 1}, [g_D(z)]_3^{\pm 1} \rangle}{4t(k-1)^{1/2}} \right)$$

for almost every $z \in D_0$ that belongs to the k -th segment. We conclude that $W_0(z, y)$ and $W_S(g(z), g(y))$ are equal for almost every pair $(z, y) \in D_0 \times G_0$.

6.8. Main part. We now focus on the values of W_0 on E_0^2 . The first constraint in Figure 13 implies that $W_0(x, y) = 0$ for almost every $x, y \in E_0^2$ with $[g_E(x)]_1 \neq [g_E(y)]_1$. Let us consider the second constraint in the figure. For almost every choice of the roots, all the roots belong to the same segment in their respective parts. Let k be the index of this segment and let z and z' be the choices of the bottom and the top roots that belong to B_0 . Further, let S and S' be the subsegments of E_0 corresponding to the subsegments of z and z' in B_0 , respectively. For almost every

choice of the roots, the root from E_0 belongs to S . The second constraint yields that the following holds for almost all $x \in S$ such that

$$(8) \quad 2^{-k} \int_{S'} W(x, y) \, dy = |S'| \cdot \frac{\text{trunc} \left(\frac{1}{2} + \frac{\langle \llbracket g_B(z) \rrbracket_1^{\pm 1}, \llbracket g_B(z') \rrbracket_1^{\pm 1} \rangle}{4t(k-1)^{1/2}} \right)}{2^k}.$$

Along the same lines, the third constraint yields that it holds for almost all $x, x' \in S$ that

$$(9) \quad 2^{-2k} \int_{S'} W(x, y)W(x', y) \, dy = |S'| \frac{\left(\text{trunc} \left(\frac{1}{2} + \frac{\langle \llbracket g_B(z) \rrbracket_1^{\pm 1}, \llbracket g_B(z') \rrbracket_1^{\pm 1} \rangle \right)}{2^k} \right)^2}{2^{2k}}.$$

By Lemma 8, the identity (9) implies that

$$(10) \quad \frac{1}{|S'|} \int_{S'} W(x, y)^2 \, dy = \left(\text{trunc} \left(\frac{1}{2} + \frac{\langle \llbracket g_B(z) \rrbracket_1^{\pm 1}, \llbracket g_B(z') \rrbracket_1^{\pm 1} \rangle}{4t(k-1)^{1/2}} \right) \right)^2$$

for almost every $x \in S$.

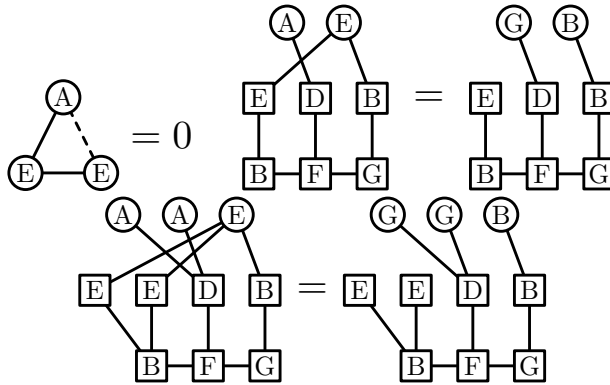

FIGURE 13. The set of decorated constraints used in Subsection 6.8.

We derive from (8) and (10) using the Cauchy-Schwarz inequality that

$$W(x, y) = \text{trunc} \left(\frac{1}{2} + \frac{\langle \llbracket g_B(z) \rrbracket_1^{\pm 1}, \llbracket g_B(z') \rrbracket_1^{\pm 1} \rangle}{4t(k-1)^{1/2}} \right)$$

for almost every $x \in S$ and every $y \in S'$. Since $\llbracket g_B(z) \rrbracket_1^{\pm 1} = \llbracket g_E(x) \rrbracket_1^{\pm 1}$ and $\llbracket g_B(z') \rrbracket_1^{\pm 1} = \llbracket g_E(y) \rrbracket_1^{\pm 1}$ for almost every such pair x and y , we conclude that $W_0(x, y)$ and $W_S(g(x), g(y))$ are equal for almost every pair $(x, y) \in E_0^2$.

6.9. Degree balancing. Fix $X \in \{A, \dots, G, P\}$. The first constraint in Figure 14 implies that

$$\int_{X_0} W_0(x, y)W_0(x', y) \, dy = K_X$$

for almost every $x, x' \in Q_0$ for some K_X . By Lemma 8, this also implies that

$$\int_{X_0} W_0(x, y)^2 dy = K_X$$

for almost every $x \in Q_0$. Hence, there exists a function $h_X : Q_0 \rightarrow [0, 1]$ such that $W_0(x, y) = h_X(y)$ for almost every $x \in Q_0$ and $y \in X_0$. Since the last constraint on the first line yields that

$$\int_{R_0} W_0(x, y) dy = \frac{4}{13}$$

for almost every $x \in X_0$ and it holds that

$$\int_{Q_0 \cup R_0} W_0(x, y) dy = \int_{Q \cup R} W_S(g_X(x), y) dy$$

for almost every $x \in X_0$ because of the already enforced structure, we conclude that $W_0(x, y)$ and $W_S(g(x), g(y))$ are equal for almost every pair $(x, y) \in X_0 \times Q_0$.

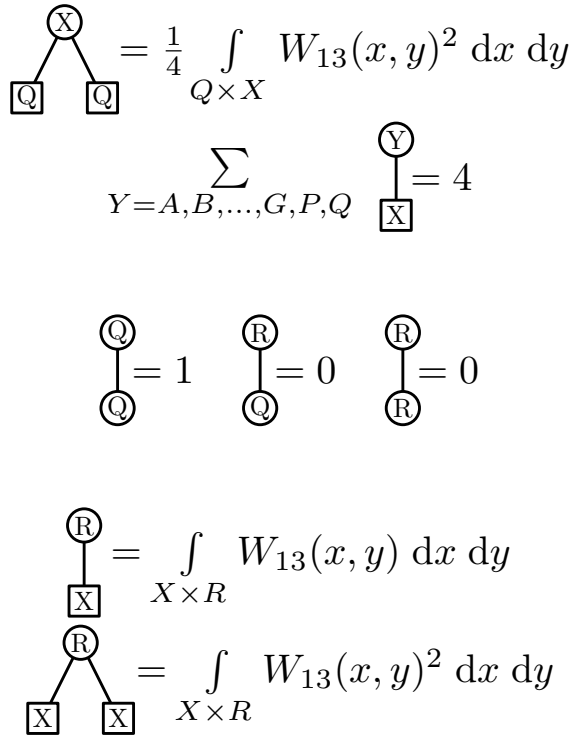

FIGURE 14. The set of decorated constraints used in Subsection 6.9 where $X \in \{A, B, C, D, E, F, G, P\}$.

The three constraints on the second line in Figure 14 clearly imply that $W_0(x, y)$ and $W_S(g(x), g(y))$ are equal for almost every pair $(x, y) \in (Q_0 \cup R_0)^2$.

Again fix $X \in \{A, \dots, G, P\}$. The two constraints on the last line in Figure 14 give using Lemma 8 that

$$\int_{R_0} W_0(x, y) \, dy = K_X |R_0| \quad \text{and} \quad \int_{R_0} W_0(x, y)^2 \, dy = K_X^2 |R_0|$$

for almost every $x \in X_0$ for some K_X . However, this is only possible if $W_0(x, y) = K_X$ for almost every $x \in X_0$ and almost every $y \in R_0$. The right side values of the two constraints yield that the values of K_X match the corresponding values in W_S . So, we can conclude that $W_0(x, y)$ and $W_S(g(x), g(y))$ are equal for almost every pair $(x, y) \in X_0 \times R_0$. Since we have shown that the constraints in Figures 4–14 imply that $W_0(x, y)$ and $W_S(g(x), g(y))$ are equal for almost every pair x and y , we have established that the Švejk graphon is finitely forcible. This completes the proof of Theorem 1.

CONCLUDING REMARK

Proposition 2 gives that it is not possible to remove $2^{5 \log^* \varepsilon_i^{-2}}$ completely from the denominator in the exponent in Theorem 1. However, our construction can be modified to replace $t(n)$ with a faster growing function of n , e.g., with $t(t(n))$, which would replace the function $2^{5 \log^* \varepsilon_i^{-2}}$ with a slower growing function of ε^{-1} . In fact, a recent result from [12] implies that $2^{5 \log^* \varepsilon_i^{-2}}$ can be replaced with any non-decreasing function of ε^{-1} growing to infinity.

ACKNOWLEDGMENTS

The authors are grateful to Jacob Fox for sparking their interest in finitely forcible graphons with weak regular partitions requiring a large number of parts and for pointing out the tightness of their construction as formulated in Proposition 2. They would also like to thank Andrzej Grzesik, Sune Jakobsen, and Fiona Skerman for discussions on the limit of the graphons W_m^{CF} , and Taisa Lopes Martins for her comments on one of the drafts of the paper. Finally, they would like to thank the anonymous reviewer for comments that helped to clarify and improve various aspects of the presentation of the results.

REFERENCES

- [1] R. Baber, *Turán densities of hypercubes*, available as arXiv:1201.3587 (2012).
- [2] Rahil Baber and John Talbot, *A solution to the 2/3 conjecture*, SIAM J. Discrete Math. **28** (2014), no. 2, 756–766, DOI 10.1137/130926614. MR3209718
- [3] Rahil Baber and John Talbot, *Hypergraphs do jump*, Combin. Probab. Comput. **20** (2011), no. 2, 161–171, DOI 10.1017/S0963548310000222. MR2769186
- [4] József Balogh, Ping Hu, Bernard Lidický, and Hong Liu, *Upper bounds on the size of 4- and 6-cycle-free subgraphs of the hypercube*, European J. Combin. **35** (2014), 75–85, DOI 10.1016/j.ejc.2013.06.003. MR3090487
- [5] Béla Bollobás and Oliver Riordan, *Sparse graphs: metrics and random models*, Random Structures Algorithms **39** (2011), no. 1, 1–38, DOI 10.1002/rsa.20334. MR2839983
- [6] Christian Borgs, Jennifer Chayes, and László Lovász, *Moments of two-variable functions and the uniqueness of graph limits*, Geom. Funct. Anal. **19** (2010), no. 6, 1597–1619, DOI 10.1007/s00039-010-0044-0. MR2594615
- [7] C. Borgs, J. T. Chayes, L. Lovász, V. T. Sós, and K. Vesztegombi, *Convergent sequences of dense graphs. I. Subgraph frequencies, metric properties and testing*, Adv. Math. **219** (2008), no. 6, 1801–1851, DOI 10.1016/j.aim.2008.07.008. MR2455626

- [8] C. Borgs, J. T. Chayes, L. Lovász, V. T. Sós, and K. Vesztergombi, *Convergent sequences of dense graphs II. Multiway cuts and statistical physics*, Ann. of Math. (2) **176** (2012), no. 1, 151–219, DOI 10.4007/annals.2012.176.1.2. MR2925382
- [9] Christian Borgs, Jennifer Chayes, László Lovász, Vera T. Sós, Balázs Szegedy, and Katalin Vesztergombi, *Graph limits and parameter testing*, STOC'06: Proceedings of the 38th Annual ACM Symposium on Theory of Computing, ACM, New York, 2006, pp. 261–270, DOI 10.1145/1132516.1132556. MR2277152
- [10] F. R. K. Chung, R. L. Graham, and R. M. Wilson, *Quasi-random graphs*, Combinatorica **9** (1989), no. 4, 345–362, DOI 10.1007/BF02125347. MR1054011
- [11] David Conlon and Jacob Fox, *Bounds for graph regularity and removal lemmas*, Geom. Funct. Anal. **22** (2012), no. 5, 1191–1256, DOI 10.1007/s00039-012-0171-x. MR2989432
- [12] J. W. Cooper, D. Král', and T. Martins, *Finitely forcible graph limits are universal*, available as arXiv:1701.03846 (2017).
- [13] Persi Diaconis, Susan Holmes, and Svante Janson, *Threshold graph limits and random threshold graphs*, Internet Math. **5** (2008), no. 3, 267–320 (2009). MR2573956
- [14] Gábor Elek, *On limits of finite graphs*, Combinatorica **27** (2007), no. 4, 503–507, DOI 10.1007/s00493-007-2214-8. MR2359831
- [15] Alan Frieze and Ravi Kannan, *Quick approximation to matrices and applications*, Combinatorica **19** (1999), no. 2, 175–220, DOI 10.1007/s004930050052. MR1723039
- [16] Roman Glebov, Carlos Hoppen, Tereza Klímošová, Yoshiharu Kohayakawa, Daniel Král', and Hong Liu, *Densities in large permutations and parameter testing*, European J. Combin. **60** (2017), 89–99. MR3567538
- [17] R. Glebov, T. Klímošová, and D. Král', *Infinite dimensional finitely forcible graphon*, available as arXiv:1404.2743 (2014).
- [18] R. Glebov, D. Král', and J. Volec, *Compactness and finite forcibility of graphons*, available as arXiv:1309.6695 (2015).
- [19] Andrzej Grzesik, *On the maximum number of five-cycles in a triangle-free graph*, J. Combin. Theory Ser. B **102** (2012), no. 5, 1061–1066, DOI 10.1016/j.jctb.2012.04.001. MR2959390
- [20] Hamed Hatami, Jan Hladký, Daniel Král', Serguei Norine, and Alexander Razborov, *Non-three-colourable common graphs exist*, Combin. Probab. Comput. **21** (2012), no. 5, 734–742, DOI 10.1017/S0963548312000107. MR2959863
- [21] Hamed Hatami, Jan Hladký, Daniel Král', Serguei Norine, and Alexander Razborov, *On the number of pentagons in triangle-free graphs*, J. Combin. Theory Ser. A **120** (2013), no. 3, 722–732, DOI 10.1016/j.jcta.2012.12.008. MR3007147
- [22] Carlos Hoppen, Yoshiharu Kohayakawa, Carlos Gustavo Moreira, Balázs Ráth, and Rudini Menezes Sampaio, *Limits of permutation sequences*, J. Combin. Theory Ser. B **103** (2013), no. 1, 93–113, DOI 10.1016/j.jctb.2012.09.003. MR2995721
- [23] C. Hoppen, Y. Kohayakawa, C. G. Moreira, and R. M. Sampaio, *Limits of permutation sequences through permutation regularity*, available as arXiv:1106.1663 (2011).
- [24] Carlos Hoppen, Yoshiharu Kohayakawa, Carlos Gustavo Moreira, and Rudini Menezes Sampaio, *Testing permutation properties through subpermutations*, Theoret. Comput. Sci. **412** (2011), no. 29, 3555–3567, DOI 10.1016/j.tcs.2011.03.002. MR2839700
- [25] Svante Janson, *Poset limits and exchangeable random posets*, Combinatorica **31** (2011), no. 5, 529–563, DOI 10.1007/s00493-011-2591-x. MR2886098
- [26] Daniel Král', Chun-Hung Liu, Jean-Sébastien Sereni, Peter Whalen, and Zelealem B. Yilma, *A new bound for the 2/3 conjecture*, Combin. Probab. Comput. **22** (2013), no. 3, 384–393, DOI 10.1017/S0963548312000612. MR3053853
- [27] Daniel Král', Lukáš Mach, and Jean-Sébastien Sereni, *A new lower bound based on Gromov's method of selecting heavily covered points*, Discrete Comput. Geom. **48** (2012), no. 2, 487–498, DOI 10.1007/s00454-012-9419-3. MR2946458
- [28] Daniel Král' and Oleg Pikhurko, *Quasirandom permutations are characterized by 4-point densities*, Geom. Funct. Anal. **23** (2013), no. 2, 570–579, DOI 10.1007/s00039-013-0216-9. MR3053756
- [29] László Lovász, *Large networks and graph limits*, American Mathematical Society Colloquium Publications, vol. 60, American Mathematical Society, Providence, RI, 2012. MR3012035
- [30] László Lovász and Vera T. Sós, *Generalized quasirandom graphs*, J. Combin. Theory Ser. B **98** (2008), no. 1, 146–163, DOI 10.1016/j.jctb.2007.06.005. MR2368030

- [31] L. Lovász and B. Szegedy, *Finitely forcible graphons*, J. Combin. Theory Ser. B **101** (2011), no. 5, 269–301, DOI 10.1016/j.jctb.2011.03.005. MR2802882
- [32] László Lovász and Balázs Szegedy, *Limits of dense graph sequences*, J. Combin. Theory Ser. B **96** (2006), no. 6, 933–957, DOI 10.1016/j.jctb.2006.05.002. MR2274085
- [33] László Lovász and Balázs Szegedy, *Testing properties of graphs and functions*, Israel J. Math. **178** (2010), 113–156, DOI 10.1007/s11856-010-0060-7. MR2733066
- [34] Oleg Pikhurko and Alexander Razborov, *Asymptotic structure of graphs with the minimum number of triangles*, Combin. Probab. Comput. **26** (2017), no. 1, 138–160, DOI 10.1017/S0963548316000110. MR3579594
- [35] Oleg Pikhurko and Emil R. Vaughan, *Minimum number of k -cliques in graphs with bounded independence number*, Combin. Probab. Comput. **22** (2013), no. 6, 910–934, DOI 10.1017/S0963548313000357. MR3111549
- [36] Alexander A. Razborov, *Flag algebras*, J. Symbolic Logic **72** (2007), no. 4, 1239–1282, DOI 10.2178/jsl/1203350785. MR2371204
- [37] Alexander A. Razborov, *On 3-hypergraphs with forbidden 4-vertex configurations*, SIAM J. Discrete Math. **24** (2010), no. 3, 946–963, DOI 10.1137/090747476. MR2680226
- [38] Alexander A. Razborov, *On the minimal density of triangles in graphs*, Combin. Probab. Comput. **17** (2008), no. 4, 603–618, DOI 10.1017/S0963548308009085. MR2433944
- [39] Vojtěch Rödl, *On universality of graphs with uniformly distributed edges*, Discrete Math. **59** (1986), no. 1-2, 125–134, DOI 10.1016/0012-365X(86)90076-2. MR837962
- [40] Andrew Thomason, *Pseudorandom graphs*, Random graphs '85 (Poznań, 1985), North-Holland Math. Stud., vol. 144, North-Holland, Amsterdam, 1987, pp. 307–331. MR930498
- [41] Andrew Thomason, *Random graphs, strongly regular graphs and pseudorandom graphs*, Surveys in combinatorics 1987 (New Cross, 1987), London Math. Soc. Lecture Note Ser., vol. 123, Cambridge Univ. Press, Cambridge, 1987, pp. 173–195. MR905280

DEPARTMENT OF COMPUTER SCIENCE, UNIVERSITY OF WARWICK, COVENTRY CV4 7AL, UNITED KINGDOM

Current address: Department of Mathematics and Statistics, McGill University, Montreal H3A 0B9, Canada

Email address: `jacob.cooper@mail.mcgill.ca`

DEPARTMENT OF MATHEMATICS, INSTITUTE FOR THEORETICAL COMPUTER SCIENCE (CE-ITI) AND THE EUROPEAN CENTRE OF EXCELLENCE NTIS (NEW TECHNOLOGIES FOR THE INFORMATION SOCIETY), UNIVERSITY OF WEST BOHEMIA, UNIVERZITNÍ 8, 306 14 PLZEŇ, CZECH REPUBLIC

Email address: `kaisert@kma.zcu.cz`

MATHEMATICS INSTITUTE, DIMAP AND DEPARTMENT OF COMPUTER SCIENCE, UNIVERSITY OF WARWICK, COVENTRY CV4 7AL, UNITED KINGDOM

Email address: `d.kral@warwick.ac.uk`

MATHEMATICAL INSTITUTE, UNIVERSITY OF OXFORD, OXFORD OX2 6GG, UNITED KINGDOM

Current address: Department of Computer Science and DIMAP, University of Warwick, Coventry CV4 7AL, United Kingdom

Email address: `j.noel@warwick.ac.uk`