

## DECOMPOSING A 4-MANIFOLD

SELMAN AKBULUT

(Communicated by Ronald A. Fintushel)

ABSTRACT. A splitting of a manifold in Kirby's problem list (no. 4.97) is given.

Gauge theory provides many fake copies of oriented closed smooth 4-manifolds  $X$  with  $b_2^+(X)$  odd. Unfortunately, there is no such example with  $b_2^+(X)$  even. In problem 4.97 of Kirby's problem list [4] the author suggested a possible candidate for such an example. Here we show that our example fails to be fake. Along the way we show some interesting splittings of Milnor fibers of some Brieskorn singularities.

Let  $Q$  be the Milnor fiber of  $z_1^2 + z_2^3 + z_3^{13}$ . In particular  $\partial Q$  is the homology sphere  $\Sigma = \Sigma(2, 3, 13)$ , and  $Q$  is a simply connected spin 4-manifold with signature  $\sigma(Q) = -16$  and the second betti number  $b_2 = 24$ , i.e. the intersection form is  $2E_8 \oplus 4H$ . It is well known that  $\Sigma$  bounds a contractible manifold  $W$ . Hence  $X = Q \smile_{\partial} W$  is homotopy equivalent to  $K3 \# S^2 \times S^2$ , where  $K3$  is the Kummer surface (i.e. quartic in  $\mathbf{CP}^3$ )

**Theorem 0.1.**  $X$  is diffeomorphic to  $Y \# S^2 \times S^2$ , where  $Y$  is a homotopy  $K3$ .

*Proof.* Clearly the Milnor fiber  $Q$  is the 13-fold branched cover of  $B^4$  along the Seifert surface of  $(2, 3)$  torus knot (i.e. the right handed trefoil knot), drawn in Figure 1.

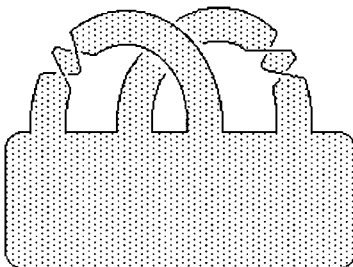

FIGURE 1

By the algorithm of [2] the handlebody picture of  $Q$  can be drawn as the handlebody of Figure 2, consisting of  $B^4$  with twenty-four 2-handles with  $(-2)$  framing (each strand has 12 circles). The number  $-1$  across the strands in Figure 2 indicates that there is one left handed twist on the strands.

---

Received by the editors January 15, 1998 and, in revised form, January 29, 1998.

1991 *Mathematics Subject Classification.* Primary 57R55; Secondary 58A03.

*Key words and phrases.* Contractible manifold, Milnor fiber.

The author was partially supported by NSF grant DMS-9626204.

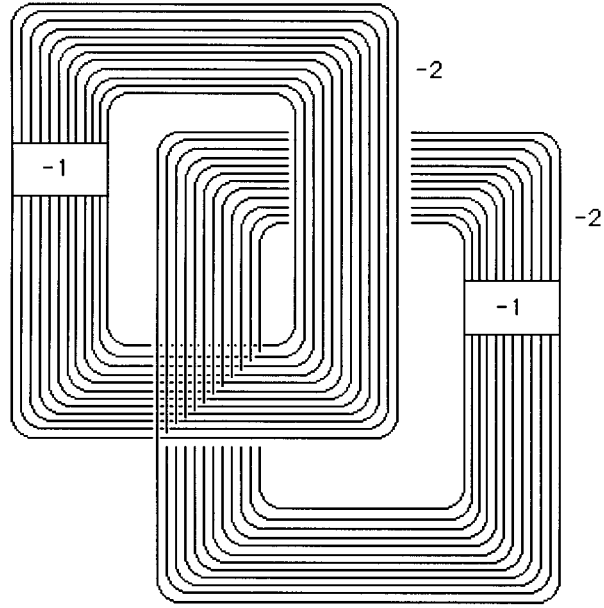

FIGURE 2

We now cap  $Q$  with a contractible 4-manifold  $W$  to get  $X = Q \cup_{\partial} W$ . We will achieve this by attaching two 2-handles and two 3-handles and one 4-handle to  $Q$ . To do this we first attach a 2-handle  $\mathbf{h}$  to  $Q$  as shown in Figure 3.

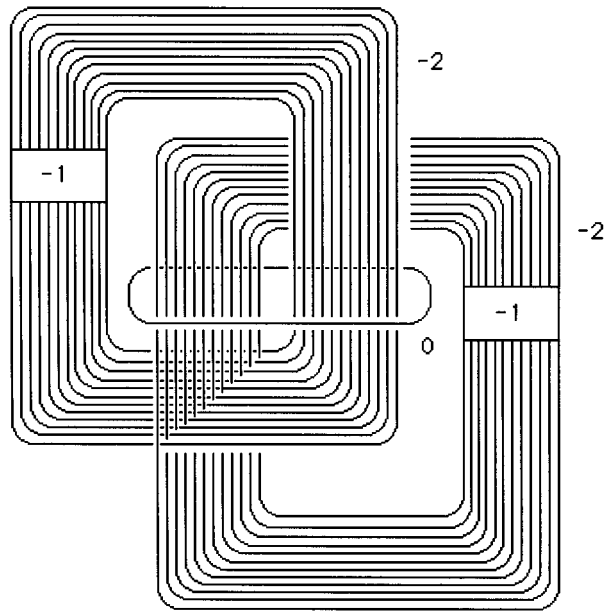

FIGURE 3

We then show that the new boundary is diffeomorphic to the boundary of the manifold  $K^0$  of Figure 10, which is a 4-ball with a 2-handle attached to a slice knot  $K$  with 0-framing. Hence  $\partial(K^0)$  is obtained from  $S^3$  by 0-surgery to the knot  $K$ , which is a slice. Let  $D^2 \subset B^4$  be the slice disc which  $K$  bounds in  $B^4$ , and let  $N(D)$  be the open tubular neighborhood of  $D$ . Since  $\partial(K^0) = \partial(B^4 - N(D))$ , we can define:

$$W = \mathbf{h} \smile_{\partial} (B^4 - N(D)).$$

From Figure 3 we can see a splitting  $X = Y \# S^2 \times S^2$  where  $Y$  is a homotopy  $K3$  surface. Here the two 2-spheres of  $S^2 \times S^2$  correspond to the 0 framed circle and one of the  $-2$  framed circles of Figure 3.

Now it remains to prove that the boundary of Figure 3 is diffeomorphic to the boundary of Figure 10: By a blowing up and down operation we see that the boundary of Figure 3 is diffeomorphic to the boundary of the the manifold in Figure 4 (blow up a  $-1$  framed circle on the 0 framed circle of Figure 3, turning it into a  $-1$  framed circle, and blow down this new  $-1$  framed circle). The framings of twenty-four 2-handles of Figure 4 are now  $-1$ .

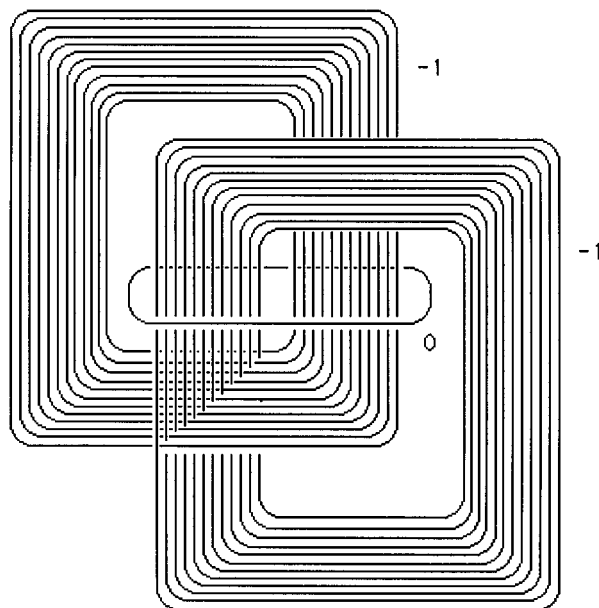

FIGURE 4

By an isotopy we can redraw Figure 4 as in Figure 5. By sliding two handles over each other we get Figure 6 (i.e. by sliding parallel vertical framed circles over each other). By blowing down  $-1$  framed circles we see that the boundary of Figure 6 is diffeomorphic to Figure 7. Then by blowing down “the indicated  $-1$  circles” of Figure 7 we get Figure 8. By surgering the indicated 0 framed circles (i.e. putting dots on them) we get Figure 9, and cancelling the 1-handles with their dual 2-handles (and blowing down the remaining circle) we obtain Figure 10.  $\square$

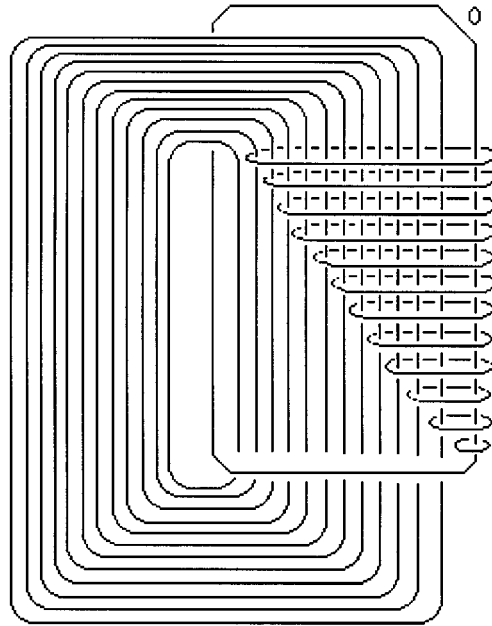

FIGURE 5

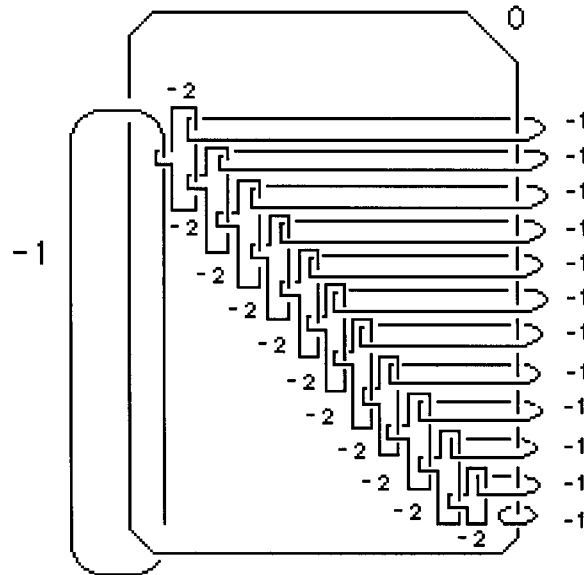

FIGURE 6

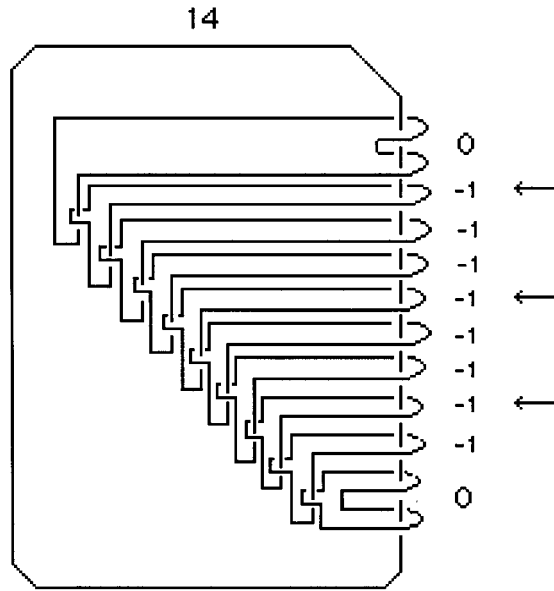

FIGURE 7

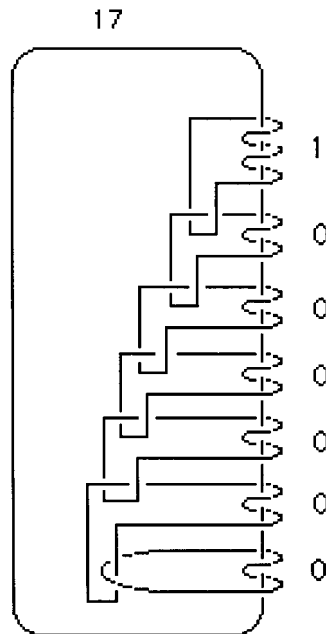

FIGURE 8

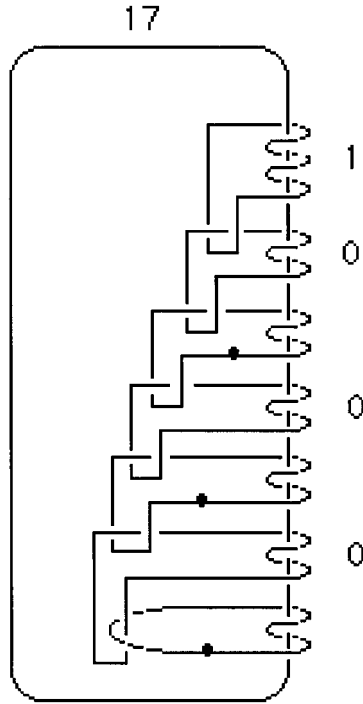

FIGURE 9

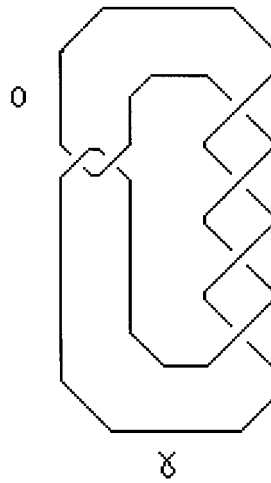

FIGURE 10

*Remark 0.2.* It is likely that  $Y$  is diffeomorphic to the  $K3$  surface: Let  $M(p, q, r)$  denote the Milnor fiber of the singularity  $z_1^p + z_2^q + z_3^r$ , so  $Q = M(2, 3, 13)$ . It can easily be seen that

$$Y = [M(2, 3, 12) \smile_{\partial} \mathbf{h}_0] \smile_{\partial} (B^4 - N(D))$$

where  $\mathbf{h}_0$  is a 2-handle. In fact the same method shows that in general:

$$M(2, 3, r) \smile_{\partial} \mathbf{h} = [ M(2, 3, r - 1) \smile_{\partial} \mathbf{h}_0 ] \# S^2 \times S^2.$$

More specifically  $M(2, 3, r)$  is obtained from  $M(2, 3, r - 1)$  by attaching two 2-handles  $M(2, 3, r) = M(2, 3, r - 1) \smile_{\partial} (\mathbf{h}_0 \cup \mathbf{h}_1)$ , and the “new” 2-handle  $\mathbf{h}$  along with  $\mathbf{h}_1$  gives the two generators of  $S^2 \times S^2$  with the intersection matrix

$$\begin{pmatrix} 0 & 1 \\ 1 & -2 \end{pmatrix}.$$

$\mathbf{h}_0$  and  $\mathbf{h}_1$  are the two “outermost” circles of the each strand of Figure 3; and  $\mathbf{h}$  is the 0-framed circle of Figure 3 (the figure is drawn for  $r = 13$ ). If we take  $\mathbf{h}_1$  to be the “lower outermost” circle, by cancelling it with  $\mathbf{h}$  we get  $M(2, 3, r - 1) \smile_{\partial} \mathbf{h}_0$ . It is easy to check that the picture of  $M(2, 3, r - 1)$  is the same as Figure 2 except that each strand has one less circle (each strand contains 11 circles in this case).

*Remark 0.3.* The reader might wonder if gluing  $Q$  to  $W$  by a diffeomorphism (along the boundary  $\Sigma$ ), which is not isotopic to identity, would still result  $X$  with the same splitting property? The diffeomorphism of  $f : \Sigma \rightarrow \Sigma$  discussed in Figure 19 of [3] can be seen to be not isotopic to identity. If  $\gamma \subset \Sigma = \partial W$  is the attaching circle of the handle  $\mathbf{h} \subset W$ , it is easy to check that  $f(\gamma)$  also bounds a disc  $D' \subset W$ . Hence  $Q \smile_f W$  would still contain  $Q \smile_{\partial} \mathbf{h}$  which gives the splitting by the remark above. The Seifert fibered space  $\Sigma$  is not likely to admit too many self-diffeomorphisms which are not isotopic to identity ( $f$  might be the only one) since homotopic self-diffeomorphisms of  $\Sigma$  are isotopic. Also, by changing  $W$  by some other obvious contractible manifolds still seems to give the splitting of the main theorem.

REFERENCES

1. S. Akbulut, *A Fake compact contractible 4-manifold*, J. Diff. Geom. **33** (1991), 335-356. MR **92b**:57025
2. S. Akbulut and R. Kirby, *Branched covers of surfaces in 4-manifolds*, Math. Ann. **252** (1980), 111-131. MR **82j**:57001
3. S. Akbulut and R. Kirby, *Mazur manifolds*, Michigan Math. J. **24** (1979), 259-284. MR **80h**:57004
4. R. Kirby, *Problems in low dimensional topology*, Geometric topology, Studies in Advanced Math. AMS/IP vol. 2, part 2 (1993).

DEPARTMENT OF MATHEMATICS, MICHIGAN STATE UNIVERSITY, EAST LANSING, MICHIGAN 48824

*E-mail address:* akbulut@math.msu.edu