

QUARTERLY OF APPLIED MATHEMATICS

Vol. XXIX

APRIL 1971

No. 1

A CLASS OF MOTIONS WITH CONSTANT STRETCH HISTORY*

BY

R. R. HUILGOL

Illinois Institute of Technology

Abstract. The purpose of this paper is to examine the kinematics and dynamics of a class of motions with constant stretch history. A kinematical result is announced to indicate the velocity field such a motion may have and two examples, viz. helical-torsional flow and the helical flow combined with the axial motion of fanned planes, are discussed in detail. The helical-torsional flow is found to be experimentally realizable, albeit approximately, and it is shown how an apparatus may be built to measure the material functions occurring in such flows. Two nonlinear differential equations are derived to determine the velocity profile when the motion under study is treated as a nearly viscometric flow. In addition, restrictions on the proper numbers of the first Rivlin-Ericksen tensor are arrived at so that the motion with constant stretch history is completely determined by the first two or first three Rivlin-Ericksen tensors. This permits a reduction in the number of terms occurring in the full expansion of the constitutive equation.

1. Introduction. This article is an examination of the kinematics and dynamics of a class of *motions with constant stretch history*,¹ delineated originally by Noll [1]. He analyzed all the possible motions that occur under the classification of *substantially stagnant motions*, a discovery of Coleman [2]. What are explored here are MWCSH of type (ii), as defined in [1] and recollected below in Sec. 2.

The main results of the paper are:

(i) examination of the conditions under which the proper numbers of the first Rivlin-Ericksen tensor A_1 are all distinct or two of them are equal but distinct from the third, when trace $A_1 = 0$: This permits us to discover when the constitutive equation is determined by A_1 and A_2 or by A_1 , A_2 and A_3 , so that the relationship with the work of Wang [3] is established (see Sec. 3);

(ii) in Sec. 4, we derive a sufficient condition under which a motion is a MWCSH. This condition is broader than the homogeneous velocity fields used by Truesdell and Noll [4, Sec. 118]; attempts are being made to see if this condition yields an intrinsically unsteady MWCSH, thereby corroborating the conclusion of Yin and Pipkin [5].

(iii) in Sec. 5, a kinematical description of MWCSH of type (ii) is given and conditions under which a (spatial) uniform steady velocity field may be added to an existing

* Received December 22, 1969.

¹ In what follows, the phrase "motion(s) with constant stretch history" will be replaced by MWCSH. The context makes it clear whether "motion" or "motions" is being implied.

MWCSH of type (ii) so that the resulting motion is still a MWCSH of type (ii) are explored. In doing so, we find a motion yielding a strain history with finite terms, but this is not a MWCSH;

(iv) in Sec. 6, the dynamics of helical-torsional flow are explored since this velocity field is approximately realizable in the laboratory so that the material functions occurring in MWCSH of type (ii) may be measured;

(v) in Sec. 7, the material functions determined from treating the helical-torsional flow as a nearly viscometric flow in the sense of Pipkin and Owen [6] are listed from elsewhere [7] and two nonlinear differential equations are obtained to determine the velocity field of the helical-torsional flow from the experimental observations;

(vi) in Sec. 8, the combined motion of helical flow with the axial motion of fanned planes is shown to be a dynamically possible MWCSH of type (ii);

(vii) and finally in Sec. 9, certain reductions in the number of terms in the constitutive equations (2.6) or (3.17) are made under appropriate conditions on the velocity field.

2. Collection of previous results. According to Noll [1], in all MWCSH the deformation gradient $F_0(\tau)$ relative to a fixed reference configuration at time 0 is given by

$$F_0(\tau) = Q(\tau)e^{\tau M}, \quad Q(0) = 1, \quad (2.1)$$

where $Q(\tau)$ is an orthogonal tensor and M is a constant tensor. In a three-dimensional vector space a linear transformation is either nilpotent of order two, or of order three or not nilpotent. Thus M in (2.1) is either

(i) nilpotent of order two, i.e., $M^2 = 0$ —such flows are called viscometric [2]; or

(ii) nilpotent of order three, i.e., $M^2 \neq 0$, $M^3 = 0$; or

(iii) not nilpotent, i.e., $M^n \neq 0$ for all $n = 1, 2, 3, \dots$.

In MWCSH, the right relative Cauchy–Green strain tensor has the form:

$$C_i(t-s) = e^{-sL^T} e^{-sL}, \quad 0 \leq s < \infty, \quad (2.2)$$

where

$$L = Q(t)MQ^T(t), \quad (2.3)$$

$$L_1 = L + \dot{Q}(t)Q^T(t), \quad (2.4)$$

where the superscript T denotes transposition, L_1 is the velocity gradient at time t and L the velocity gradient in a rotating frame of reference [1]. In MWCSH of type (ii), which will be studied in this article,

$$C_i(t-s) = 1 - sA_1 + \frac{1}{2}s^2A_2 - \frac{1}{3!}s^3A_3 + \frac{1}{4!}s^4A_4, \quad (2.5)$$

where A_i ($i = 1, \dots, 4$) are the first four Rivlin–Ericksen tensors. According to Theorem 2 of Noll [1], MWCSH of type (ii) are *isochoric* as well. Examples of such motions are given below.

Now, Wang [3] has proved that in all MWCSH, the extra stress T_E in an incompressible simple fluid [8] is given by

$$T_E = T + p1 = f(A_1, A_2, A_3), \quad (2.6)$$

where T is the stress tensor determined up to an arbitrary hydrostatic pressure p and $f(\cdot)$ is an isotropic function of its arguments. In fact, Wang [3] showed that there exist

three separate cases under which a representation of the type (2.6) is valid, the three cases depending on the proper numbers of \mathbf{A}_1 . This question will be discussed next.

If a material is incompressible, all motions possible in this material are subject to the condition

$$\text{tr } \mathbf{A}_1 = 0, \quad (2.7)$$

where tr is the trace operator. Hence, if \mathbf{A}_1 has three proper numbers which are all equal, incompressibility demands that $\mathbf{A}_1 = \mathbf{0}$, which implies a rigid motion. Thus for a non-trivial motion to occur in incompressible materials, \mathbf{A}_1 must have either (i) three distinct proper numbers or (ii) two proper numbers equal but different from the third. Not only this, if the two proper numbers are equal but distinct from the third in a MWCSH, the matrix of \mathbf{A}_2 , relative to the orthonormal basis for which the matrix of \mathbf{A}_1 is given by

$$[\mathbf{A}_1] = \begin{vmatrix} a & 0 & 0 \\ 0 & a & 0 \\ 0 & 0 & b \end{vmatrix}, \quad a \neq b, \quad (2.8)$$

must be such that

$$[\mathbf{A}_2] \neq \begin{vmatrix} a^2 & 0 & 0 \\ 0 & a^2 & 0 \\ 0 & 0 & b^2 \end{vmatrix}, \quad (2.9)$$

if the MWCSH is of type (ii). Otherwise, the MWCSH will be of type (iii), generated by a non-nilpotent tensor, and will be equivalent to simple extension [3, 7, 9]. Thus the next section examines the conditions under which the proper numbers of \mathbf{A}_1 , subject to (2.7), are either distinct or two of them are equal.

3. Proper numbers of \mathbf{A}_1 . Let the matrix of \mathbf{A}_1 relative to an orthonormal basis be given by

$$[\mathbf{A}_1] = \kappa \begin{vmatrix} a_1 & l & m \\ l & a_2 & n \\ m & n & a_3 \end{vmatrix}, \quad \kappa > 0, \quad (3.1)$$

$$a_1 + a_2 + a_3 = 0, \quad (3.2)$$

$$a_1^2 + a_2^2 + a_3^2 + l^2 + m^2 + n^2 = 1. \quad (3.3)$$

Consider the characteristic equation of $\kappa^{-1}\mathbf{A}_1$. This reads:

$$\lambda^3 - (1 + a_1a_2 - a_3^2)\lambda + a_3l^2 + a_2m^2 + a_1n^2 - a_1a_2a_3 - 2lmn = 0. \quad (3.4)$$

If the three roots of (3.4) are λ_1 , λ_2 , and λ_3 , then they obey

$$\lambda_1 + \lambda_2 + \lambda_3 = 0, \quad (3.5)$$

$$\lambda_1\lambda_2 + \lambda_2\lambda_3 + \lambda_3\lambda_1 = a_3^2 - a_1a_2 - 1, \quad (3.6)$$

$$\lambda_1\lambda_2\lambda_3 = 2lmn + a_1a_2a_3 - a_3l^2 - a_2m^2 - a_1n^2. \quad (3.7)$$

Without loss of generality, take $\lambda_1 = \lambda_2 \neq \lambda_3$. Then we obtain

$$\lambda_3 = -2\lambda_1, \quad 3\lambda_1^2 = 1 + a_1a_2 - a_3^2, \quad (3.8)$$

$$2\lambda_1^3 = a_3l^2 + a_2m^2 + a_1n^2 - a_1a_2a_3 - 2lmn. \quad (3.9)$$

Thus $\lambda_1 = \lambda_2$ whenever

$$27(a_3l^2 + a_2m^2 + a_1n^2 - a_1a_2a_3 - 2lmn)^2 = 4(1 + a_1a_2 - a_3^2)^3, \quad (3.10)$$

where the numbers a_1, a_2, \dots, n obey (3.2) and (3.3).

Suppose there is an orthonormal basis such that the matrix of \mathbf{A}_1 has the form (3.1) with

$$a_1 = a_2 = a_3 = 0. \quad (3.11)$$

Thus (3.3) now reads

$$l^2 + m^2 + n^2 = 1, \quad (3.12)$$

while (3.10) now becomes

$$27l^2m^2n^2 = 1. \quad (3.13)$$

Together, (3.12) and (3.13) imply that

$$\frac{1}{3}(l^2 + m^2 + n^2) = \frac{1}{3}, \quad (l^2m^2n^2)^{1/3} = \frac{1}{3}, \quad (3.14)$$

must be satisfied simultaneously if \mathbf{A}_1 has two equal proper numbers. Since the arithmetic mean is greater than the geometric mean, (3.14)₁ and (3.14)₂ are not consistent unless [10, p. 17]

$$l^2 = m^2 = n^2 = \frac{1}{3}. \quad (3.15)$$

Hence, in particular, we may read off the results:

(i) if \mathbf{A}_1 has the form (3.1), $a_i = 0$ ($i = 1, 2, 3$) and l, m, n obey (3.12), then it has three unequal proper numbers if and only if (3.15) is not satisfied; otherwise two of its proper numbers are equal, but distinct from the third;

(ii) in particular, from the results of Noll [1], one has that the matrix of \mathbf{L} , has the form

$$[\mathbf{L}] = \kappa \begin{vmatrix} 0 & 0 & 0 \\ l & 0 & 0 \\ m & n & 0 \end{vmatrix}, \quad l^2 + m^2 + n^2 = 1, \quad (3.16)$$

with respect to an orthonormal basis, if the motion be a MWCSH of type (ii). Thus in these flows, the matrix of \mathbf{A}_1 obeys (3.1), (3.11) and (3.12). Hence if the flow be a MWCSH of type (ii) and (3.15) is not satisfied, the constitutive equation (2.6) reads

$$\mathbf{T}_E = \mathbf{T} + p\mathbf{1} = f(\mathbf{A}_1, \mathbf{A}_2); \quad (3.17)$$

otherwise (2.6) is the correct form.

Wang [3] stated that in MWCSH of type (ii), \mathbf{A}_1 has three distinct proper numbers or two of them are equal, but the restriction on \mathbf{A}_1 given here delineates the conditions under which (2.6) or (3.17) is the correct form. This result was derived by the author in [7].

4. A sufficient condition for a given motion to be a MWCSH. It is a well-known result in continuum mechanics [11] that with respect to a fixed reference configuration at time 0:

$$(d/d\tau)\mathbf{F}_0(\tau) = \mathbf{L}_1(\tau)\mathbf{F}_0(\tau), \quad (4.1)$$

where \mathbf{L}_1 is the velocity gradient at time τ . Suppose that the material derivative of $\mathbf{L}_1(\tau)$ is zero, i.e.,

$$(d/d\tau)\mathbf{L}_1(\tau) = (\partial/\partial\tau)\mathbf{L}_1 + \mathbf{v} \cdot \text{grad } \mathbf{L}_1 = \mathbf{0}, \quad (4.2)$$

where \mathbf{v} is the velocity at time τ and position \mathbf{x} in space. Now, if (4.2) holds, (4.1) can be integrated to give

$$\mathbf{F}_0(\tau) = e^{\tau\mathbf{L}_1} \quad (4.3)$$

since $\mathbf{F}_0(0) = \mathbf{1}$. Now, if (4.3) is compared with (2.1) it is obvious that (4.3) represents the deformation gradient of a MWCSH with $\mathbf{Q}(\tau) = \mathbf{1}$ always. Thus we have established a sufficient condition for a flow to generate MWCSH as follows: *if the velocity gradient has a vanishing material derivative, the motion is one with constant stretch history.*

The above result is more general than the homogeneous velocity fields considered by Truesdell and Noll [4, Sec. 118]. Moreover, the condition that $\dot{\mathbf{L}}_1 = \mathbf{0}$ is satisfied by velocity fields of the type

$$\mathbf{v} = \mathbf{f}(t) + \mathbf{g}(\mathbf{x}), \quad \mathbf{v} \cdot \text{grad } \mathbf{g} = \mathbf{0}. \quad (4.4)$$

It must be noted that (4.4)₁ is not necessarily a steady velocity field in a non-inertial frame of reference. On using the concept of *equivalent motions* [8, Sec. 11], the reader can verify that

$$\dot{x} = ky, \quad \dot{y} = 0, \quad \dot{z} = f(t) \quad (4.5)$$

is steady in a non-inertial frame, while

$$\dot{x} = f(t) + \exp x, \quad \dot{y} = \dot{z} = 0, \quad f(t) \neq 0 \quad (4.6)$$

is not steady anywhere, i.e., *intrinsically unsteady*. The above discussion is not irrelevant to MWCSH because recently Yin and Pipkin [5, Sec. 7] constructed an intrinsically unsteady viscometric flow, possible over a *finite* time interval, thereby showing that Pipkin's assumption to the contrary [12, p. 89] was not correct. It would, therefore, be of interest to find if there exists an intrinsically unsteady motion such that $\dot{\mathbf{L}}_1 = \mathbf{0}$, for then this flow would yield a MWCSH that is intrinsically unsteady over an indefinite interval.

Incidentally, (4.4)₁ represents the superposition of a uniform velocity field onto an existing velocity field. It may be erroneously assumed that, since the uniform velocity field $\mathbf{f}(t)$ gives rise to a rigid motion by itself, the addition of $\mathbf{f}(t)$ should have no effect on the strain history. That such an assumption is false will be demonstrated by a counter-example in Sec. 5.

5. MWCSH of type (ii). It is well known through the work of Noll [1] that the following velocity field

$$\dot{x}^1 = 0, \quad \dot{x}^2 = v(x^1), \quad \dot{x}^3 = w(x^1), \quad (5.1)$$

(where $v(\cdot)$ and $w(\cdot)$ are smooth functions of x^1) in a curvilinear orthogonal coordinate

system $\{x^k\}_1^3$ is a viscometric flow if the components of the metric tensor $g_{i\alpha}$ ($i = 1, 2, 3$; no sum) do not vary along the path line of the particle. It was established by the author [13] that under the above restrictions on the coordinate system and the components of the metric tensor, the following velocity field

$$\begin{aligned} \dot{x}^1 &= 0, \\ \dot{x}^2 &= -cx^2 + ex^3, \quad c^2 + ef = 0, \\ \dot{x}^3 &= fx^2 + cx^3, \end{aligned} \quad (5.2)$$

where c , e and f are constants, is a viscometric flow. For the path lines corresponding to (5.2) are obtained by integrating the equations

$$d\xi^1/ds = 0, \quad d\xi^2/ds = c\xi^2 - e\xi^3, \quad d\xi^3/ds = -f\xi^2 - c\xi^3, \quad (5.3)$$

under the initial conditions $\xi^i|_{s=0} = x^i$ ($i = 1, 2, 3$). The path lines are:

$$\begin{aligned} \xi^1 &= x^1, \\ \xi^2 &= x^2 + c \int_0^s \xi^2 d\sigma - e \int_0^s \xi^3 d\sigma, \\ \xi^3 &= x^3 - f \int_0^s \xi^2 d\sigma - c \int_0^s \xi^3 d\sigma. \end{aligned} \quad (5.4)$$

On adding (5.4)₂ and (5.4)₃, and using $c^2 + ef = 0$, we get

$$f\xi^2 + c\xi^3 = fx^2 + cx^3. \quad (5.5)$$

Using (5.5) in (5.4)₂ and ₃ for ξ^2 and ξ^3 respectively, we get

$$\xi^2 = x^2 - s(ex^3 - cx^2), \quad (5.6)$$

$$\xi^3 = x^3 - s(fx^2 + cx^3). \quad (5.7)$$

It is easily verified that (5.4), and (5.6)–(5.7) are the path lines of a viscometric flow.

It will now be proved that the superposition of (5.1) on (5.4), viz.

$$\begin{aligned} \dot{x}^1 &= 0, \\ \dot{x}^2 &= v(x^1) - cx^2 + ex^3, \\ \dot{x}^3 &= w(x^1) + fx^2 + cx^3, \end{aligned} \quad (5.8)$$

is a MWCSH of type (ii) provided

(a) the coordinate system $\{x^k\}$ is a curvilinear orthogonal system; and

(b) the components of the metric tensor $g_{i\alpha}$ ($i = 1, 2, 3$; no sum) do not vary along the path line of each particle.

It is easily demonstrated that if the velocity field (5.8) is integrated, using the earlier notation of ξ and \mathbf{x} , one obtains [13]:

$$\begin{aligned} \xi^1 &= x^1, \\ \xi^2 + x^2 - s[v(x^1) - cx^2 + ex^3] + \frac{1}{2}s^2[ew(x^1) - cv(x^1)], \\ \xi^3 + x^3 - s[w(x^1) + fx^2 + cx^3] + \frac{1}{2}s^2[fv(x^1) + cw(x^1)]. \end{aligned} \quad (5.9)$$

It is a simple calculation to show that the matrix form of $F_t(t - s)$ is given by

$$[F_t(t - s)] = [1] - s[L] + \frac{1}{2}[L^2], \quad (5.10)$$

where L has the matrix form

$$[L] = \begin{vmatrix} 0 & 0 & 0 \\ (g_{22}g_{11}^{-1})^{1/2}v' & -c & (g_{22}g_{33}^{-1})^{1/2}e \\ (g_{33}g_{11}^{-1})^{1/2}w' & (g_{33}g_{22}^{-1})^{1/2}f & c \end{vmatrix} \quad (5.11)$$

and

$$v' = dv/dx^{1'} \quad w' = dw/dx^{1'}.$$

Also, the motion (5.8) is isochoric and in view of (5.10) and (5.11), it meets all the conditions of Theorem 2 of Noll [1] and is thus a MWCSH of type (ii), provided

$$ew' \neq cv', \quad \text{or} \quad fv' \neq cw'. \quad (5.12)$$

If one were to examine the matrix of L^2 , one finds that if (5.12) holds, then $L^2 = 0$ or the motion (5.8) becomes viscometric. But as will be seen below, in the examples considered $c = 0$ and thus the above condition is not met, and so the flows considered below are truly MWCSH of type (ii).

Now, the simplest case of a MWCSH of type (ii) occurs whenever conditions (a) and (b) are met and the velocity field is such that \dot{x}^2 depends linearly on x^3 , while \dot{x}^3 is an *arbitrary, smooth function* of x^1 . Such an example was constructed by Oldroyd [14]. This is the Poiseuille-torsional flow, viz., $\dot{r} = 0$, $\dot{\theta} = cz$, $\dot{z} = u(r)$ in a cylindrical polar coordinate system. Of course, the Poiseuille-torsional flow as well as the example of Noll [1, Sec. 3] are special cases of (5.8). It is apparent that out of the few kinematically possible combinations existing in (5.8), the helical-torsional flow, viz.

$$\dot{r} = 0, \quad \dot{\theta} = \omega(r) + cz, \quad \dot{z} = u(r), \quad (5.13)$$

in a cylindrical polar coordinate system with $\omega(\cdot)$ and $u(\cdot)$ being smooth functions of r , and c being a constant, provides an approximate, experimentally realizable situation to measure the material functions occurring in MWCSH of type (ii).

As Oldroyd [14] remarked, the flow (5.13) with $\omega(r) = 0$ can be generated, in principle, "in a limited region by rotating two porous disks, at different speeds, about a common axis placed along the axis of a circular pipe of approximately the same radius as the disks, so as to impose a torsional motion on the liquid flowing down the pipe." Thus the helical-torsional flow can be generated in between two concentric cylinders by rotating two porous rings at different speeds in the annular space between the two cylinders, provided the width of each porous ring is almost equal to the annular space between the two cylinders (see Fig. 1). It is obvious that the two motions discussed here are approximately realizable because the boundary conditions are not met on the cylinders.

In the next section, the dynamical equations connected with (5.13) are solved and it is demonstrated that the material functions occurring in the flow (5.13) can be measured by the helical-torsional rheometer described above.

Before proceeding further, it is essential to note that (5.8) remains a MWCSH of

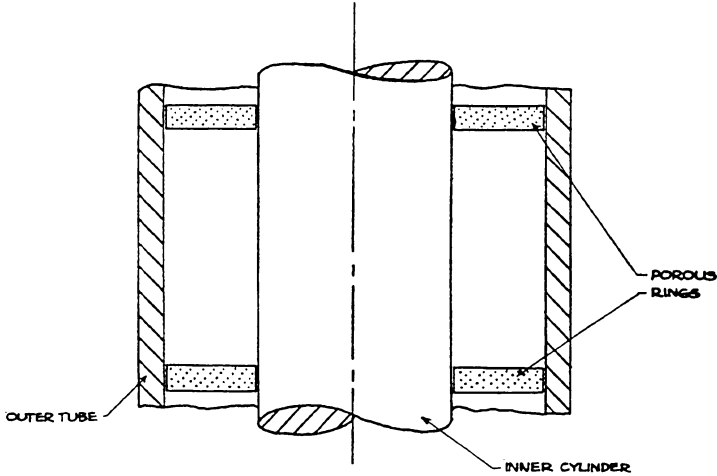

FIG. 1

type (ii) if it is replaced by

$$\begin{aligned} \dot{x}^1 &= u_0, \\ \dot{x}^2 &= v_0 + v(x^1) - cx^2 + ex^3, \\ \dot{x}^3 &= w_0 + w(x^1) + fx^2 + cx^3, \end{aligned} \quad (5.14)$$

provided

- (a) the conditions on the coordinate system and the metric tensor are met; and either
 (b) $u_0 = 0$ and apart from the restriction (5.12) no other restrictions on $v(x^1)$ and $w(x^1)$ are imposed; or
 (c) $u_0 \neq 0$ and $v(x^1) = \alpha x^1$, $w(x^1) = \beta x^1$, where α and β are constants, i.e., $v(x^1)$ and $w(x^1)$ are linear in x^1 , and $\beta e \neq c\alpha$ or $\alpha f \neq -\beta c$ [cf. (5.12)].

What is being stated is that one cannot add an arbitrary uniform velocity field to an existing velocity field (in the spatial description), and expect the character of the flow to remain substantially the same. That one of the conditions (b) or (c) is essential is demonstrated by the following example in Cartesian coordinates:

$$\dot{x} = u_0, \quad \dot{y} = x^2, \quad \dot{z} = y, \quad (5.15)$$

which is a MWCSH of type (ii) if $u_0 = 0$ and not otherwise. Further if $u_0 = 0$, note that $\dot{L}_1 = 0$, thereby providing an example to the discussion in Sec. 4; and, in addition if $u_0 \neq 0$, (5.15) is a nonviscometric flow which is not a MWCSH but which has a *strain history with a finite number of terms* in its expansion, viz.:

$$C_i(t-s) = 1 + \sum_{n=1}^6 ((-1)^n s^n A_n / n!) \quad (5.16)$$

as can be verified easily by direct calculation. It is believed to be the first example of this kind available in the literature.

Moreover, as may be anticipated, (5.8) does not exhaust the kinematical possibility

of MWCSH of type (ii). For example, the following homogeneous motion in Cartesian coordinates, viz.

$$\begin{aligned} \dot{x} &= ay + bz, \\ \dot{y} &= -cy + ez, \quad c^2 + ef = 0 \\ \dot{z} &= fy + cz, \end{aligned} \quad (5.17)$$

is also a MWCSH of type (ii). For the velocity gradient \mathbf{L}_1 is such that $\mathbf{L}_1^2 \neq \mathbf{0}$, $\mathbf{L}_1^3 = \mathbf{0}$.

6. Helical-torsional flow. Let the matrix of \mathbf{L} relative to an orthonormal basis for a MWCSH of type (ii) be given by (cf. (5.11)):

$$[\mathbf{L}] = \kappa \begin{vmatrix} 0 & 0 & 0 \\ l & 0 & 0 \\ m & n & 0 \end{vmatrix}, \quad \kappa > 0, \quad (6.1)$$

$$l^2 + m^2 + n^2 = 1. \quad (6.2)$$

Let the material functions occurring in this flow be denoted by [13]:

$$\begin{aligned} \Sigma_1 &= T_E\langle 22 \rangle - T_E\langle 11 \rangle, & \Sigma_2 &= T_E\langle 33 \rangle - T_E\langle 11 \rangle, \\ \tau_1 &= T_E\langle 12 \rangle, & \tau_2 &= T_E\langle 13 \rangle, & \tau_3 &= T_E\langle 23 \rangle, \end{aligned} \quad (6.3)$$

where $T_E \langle ij \rangle$ represents the physical component of \mathbf{T}_E in the ij th direction and the Σ_i ($i = 1, 2$) and τ_j ($j = 1, 2, 3$) are all functions of κ , l , m and n . If \mathbf{L} has the matrix form (6.1), then \mathbf{A}_1 has the matrix form (3.1) with $a_i = 0$ ($i = 1, 2, 3$).

For the helical-torsional flow (5.13), it is easy to show that [13]

$$\begin{aligned} \Sigma_1 &= T_E\langle zz \rangle - T_E\langle rr \rangle, & \Sigma_2 &= T_E\langle \theta\theta \rangle - T_E\langle rr \rangle, \\ \tau_1 &= T_E\langle rz \rangle, & \tau_2 &= T_E\langle r\theta \rangle, & \tau_3 &= T_E\langle \theta z \rangle. \end{aligned} \quad (6.4)$$

For, if one were to integrate the velocity field (5.13) and obtain the path lines and find the strain history \mathbf{C}_i ($t - s$), it will turn out that relative to the orthonormal basis of cylindrical polar coordinate system, \mathbf{L} has the matrix form [13]

$$[\mathbf{L}] = \begin{vmatrix} 0 & 0 & 0 \\ r\omega' & 0 & cr \\ u' & 0 & 0 \end{vmatrix}, \quad \omega' = \frac{d\omega}{dr}, \quad u' = \frac{du}{dr}. \quad (6.5)$$

Thus a rotation of the axes is needed so that the matrix form of the rotated tensor has the form given by (6.1). It is easy to show that the orthogonal tensor \mathbf{Q} with components

$$[\mathbf{Q}] = \begin{vmatrix} 1 & 0 & 0 \\ 0 & 0 & 1 \\ 0 & 1 & 0 \end{vmatrix} \quad (6.6)$$

will transform \mathbf{L} in (6.5), through \mathbf{QLQ}^T , to take the matrix form (6.1) with

$$\kappa l = u', \quad \kappa m = r\omega', \quad \kappa n = cr. \quad (6.7)$$

Now, from Truesdell and Noll [4, Sec. 109], it is known that in MWCSH

$$\mathbf{T}_E = \mathbf{g}(\mathbf{L}) \quad (6.8)$$

where \mathbf{g} is an isotropic function of \mathbf{L} , i.e.,

$$\mathbf{Q}\mathbf{g}(\mathbf{L})\mathbf{Q}^T = \mathbf{g}(\mathbf{Q}\mathbf{L}\mathbf{Q}^T) \quad (6.9)$$

for all constant orthogonal tensors \mathbf{Q} . Hence, applying (6.9) and retracing the steps, (6.4) is obtained from (6.3).

The dynamical equations, under the assumption that the body force \mathbf{b} per unit mass is derivable from a potential ψ through $\mathbf{b} = -\text{grad } \psi$, and by using a modified pressure function ϕ defined through

$$\phi = p + \rho\psi, \quad (6.11)$$

where ρ is the density of the fluid, take the following form in cylindrical polar coordinates for the flow (5.13):

$$\begin{aligned} -(\partial\phi/\partial r) + (\partial/\partial r)T_E \langle rr \rangle + (1/r)(T_E \langle rr \rangle - T_E \langle \theta\theta \rangle) &= 0, \\ - (1/r)(\partial\phi/\partial\theta) + (\partial/\partial r)T_E \langle r\theta \rangle + (2/r)T_E \langle r\theta \rangle &= 0, \\ - (\partial\theta/\partial z) + (\partial/\partial r)T_E \langle rz \rangle + (1/r)T_E \langle rz \rangle &= 0. \end{aligned} \quad (6.12)$$

Note that the inertia terms have been neglected in (6.12), for otherwise the torsional flow term crz makes the equations incompatible. Further, since all quantities κ , l , m and n are dependent on r , so are the extra stresses \mathbf{T}_E and this fact has been used in (6.12).

The solutions are:

$$\begin{aligned} \phi &= -az + h(r), & \tau_2 &= T_E \langle r\theta \rangle = M/2\pi r^2, \\ \tau_1 &= T_E \langle rz \rangle = -\frac{1}{2}ar + br^{-1}, & h'(r) &= (d/dr)T_E \langle rr \rangle - (1/r)\Sigma_2. \end{aligned} \quad (6.13)$$

In (6.13), a is the modified pressure drop per unit length and M is the torque per unit height needed to maintain the rotation of the cylinders in relative motion. The torque needed to maintain the upper (or lower) porous ring in rotation yields $T_E \langle \theta z \rangle$ or the material function τ_3 .

Now, from (6.4), we have that

$$(\partial/\partial r)T \langle zz \rangle = (\partial/\partial r)T \langle rr \rangle + (\partial/\partial r)\Sigma_1. \quad (6.14)$$

If the body force is assumed to act along the z axis only, we get, on noting that $\partial/\partial r = d/dr$:

$$T \langle zz \rangle = az + \int_a^r \left(\frac{1}{\xi} \Sigma_2 + \frac{d}{d\xi} \Sigma_1 \right) d\xi, \quad \alpha > 0. \quad (6.15)$$

Thus

$$T \langle zz \rangle(r) - T \langle zz \rangle(R_1) = \int_{R_1}^r \frac{1}{\xi} \Sigma_2 d\xi + \Sigma_1(r) - \Sigma_1(R_1), \quad R_1 \leq r \leq R_2. \quad (6.16)$$

Hence the thrust on one of the porous rings would yield a combination of Σ_1 and Σ_2 . Next, using the assumption that the body force acts along the z -axis only, we have from (6.12)₁:

$$(d/dr)T \langle rr \rangle = (1/r)(T_E \langle \theta\theta \rangle - T_E \langle rr \rangle) = (1/r)\Sigma_2, \quad (6.17)$$

or

$$T\langle rr\rangle(R_2) - T\langle rr\rangle(R_1) = \int_{R_1}^{R_2} \frac{1}{r} \Sigma_2 dr. \quad (6.18)$$

Thus, (6.16) and (6.17) determine Σ_1 and Σ_2 , while (6.13)₂ yields τ_2 ; the torque on the porous ring, which is

$$T = 2\Pi \int_{R_1}^{R_2} \tau_3 r^2 dr, \quad (6.19)$$

gives τ_3 . However, before τ_1 can be determined completely, the constant b must be found. Note that $b = 0$ in Poiseuille-torsional flow and thus

$$\tau_1(\kappa, u/\kappa, 0, cr/\kappa) = -\frac{1}{2}ar, \quad \kappa^2 = u'^2 + c^2r^2. \quad (6.20)$$

However, for the helical-torsional flow, b cannot be determined from theoretical considerations alone, as will become apparent below.

To appreciate the difficulty, we turn to the helical flow analysis of Coleman and Noll [15] and note that their procedure uses the following steps:

- (i) the constant b is determined from a knowledge of the viscometric shear stress function $\tau(\kappa)$ and the rate of shear κ ;
- (ii) since the functions $\omega(r)$ and $u(r)$ satisfy certain boundary conditions in helical flow, they are found next.

It is clear that this procedure is not applicable here, for the helical-torsional flow is the first known experimental situation to measure τ_1 and τ_2 ; also the torsional flow term introduces inertial effects which are not balanced in the equations of motion and the boundary conditions are not exactly satisfied. Thus it does not seem that b , $\omega(r)$ and $u(r)$ can be determined from theoretical considerations alone. Hence in Sec. 7, a pair of nonlinear differential equations are derived to determine $\omega(r)$ and $u(r)$ by assuming the helical-torsional flow to be a nearly viscometric flow in the sense of Pipkin and Owen [6] and that b can be measured experimentally.

For the convenience of the reader, we list below, in physical components form, the first four Rivlin-Ericksen tensors of the helical-torsional flow:

$$[\mathbf{A}_1] = \begin{vmatrix} 0 & r\omega' & u' \\ \cdot & 0 & cr \\ \cdot & \cdot & 0 \end{vmatrix} \quad [\mathbf{A}_2] = \begin{vmatrix} 2(r^2\omega'^2 + u'^2) & cru' & 2cr^2\omega' \\ \cdot & 0 & 0 \\ \cdot & \cdot & 2c^2r^2 \end{vmatrix} \quad (6.21)$$

$$[\mathbf{A}_3] = \begin{vmatrix} 6cr^2\omega'u' & 0 & 3c^2r^2u' \\ \cdot & 0 & 0 \\ \cdot & \cdot & 0 \end{vmatrix} \quad [\mathbf{A}_4] = \begin{vmatrix} 6c^2r^2u'^2 & 0 & 0 \\ \cdot & \cdot & 0 \\ \cdot & \cdot & 0 \end{vmatrix} \quad (6.22)$$

Also, a repeated application of the isotropy condition (6.9) shows that [13]:

$$\begin{aligned} \Sigma_i(\kappa, l, m, n) &= \Sigma_i(\kappa, -l, -m, n) = \Sigma_i(\kappa, -l, m, -n) \\ &= \Sigma_i(\kappa, l, -m, -n), \quad i = 1, 2; \end{aligned} \quad (6.23)$$

$$\tau_1(\kappa, l, m, n) = -\tau_1(\kappa, -l, -m, n) = -\tau_1(\kappa, -l, m, -n) = \tau_1(\kappa, l, -m, -n), \quad (6.24)$$

$$\begin{aligned} \tau_2(\kappa, l, m, n) &= -\tau_2(\kappa, -l, -m, n) = \tau_2(\kappa, -l, m, -n) \\ &= -\tau_2(\kappa, l, -m, -n); \end{aligned} \quad (6.25)$$

$$\tau_3(\kappa, l, m, n) = \tau_3(\kappa, -l, -m, n) = -\tau_3(\kappa, -l, m, -n) = -\tau_3(\kappa, l, -m, -n). \quad (6.26)$$

For example, one can prove from (6.24) that

$$\tau_1(\kappa, 0, 0, 1) = 0, \quad (6.27)$$

with similar results for other shear stress functions.

7. A procedure to determine $\omega(r)$ and $u(r)$. Let us assume that the torsional flow term crz is so small that the helical-torsional flow is nearly viscometric [6]. Then the author has shown that [7]:

$$\begin{aligned} \tau_1 &= \eta u' + (\phi - \nu)cr^2\omega' + \left(\frac{5}{2}\nu - 2\phi\right)\frac{cr^2\omega'u'^2}{\kappa^2} \\ &\quad + \frac{cr^2\omega'u'^2}{\kappa^2}\delta S_{2323}[\kappa | s^2] - \frac{cr^2\omega'u'}{\kappa^2}f(\kappa, s), \end{aligned} \quad (7.1)$$

$$\begin{aligned} \tau_2 &= \eta\omega' + \left(\phi - \frac{\nu}{2}\right)cr\omega' - \frac{\nu}{2}\frac{cr\omega'^3}{\kappa^2} + 2(\nu - \phi)\frac{cr^3\omega'^2u'}{\kappa^2} \\ &\quad - \frac{cr\omega'^3}{\kappa^2}\delta S_{2323}[\kappa | s^2] - \frac{cr^3\omega'^2u'}{\kappa^3}f(\kappa, s), \end{aligned} \quad (7.2)$$

$$\begin{aligned} \tau_3 &= \eta cr + \phi r\omega'u' - \eta\frac{3cr^3\omega'^2u'^2}{\kappa^4} \\ &\quad + \frac{cr\omega'^2(r^2\omega'^2 - u'^2)}{\kappa^3}\delta S_{1323}[\kappa | s^2] - \frac{cr^3\omega'^2u'^2}{\kappa^3}g(\kappa, s) - \frac{2cr^3\omega'^2u'^2}{\kappa^3}h(\kappa, s), \end{aligned} \quad (7.3)$$

where $\eta = \eta(\kappa)$, $\phi = \phi(\kappa)$, $\nu = \nu(\kappa)$, $\kappa = r^2\omega'^2 + u'^2$,

$$f(\kappa, s) = \delta S_{1211}[\kappa | s] + \delta S_{1222}[\kappa | s] + \kappa^2\{\delta S_{1222}[\kappa | s^3] + 2\delta S_{1211}[\kappa | s^3]\}, \quad (7.4)$$

$$g(\kappa, s) = 5\delta S_{2211}[\kappa | s] + \delta S_{2222}[\kappa | s] + \kappa^2\{2\delta S_{2211}[\kappa | s^3] + \delta S_{2222}[\kappa | s^3]\}, \quad (7.5)$$

$$h(\kappa, s) = 5\delta S_{1111}[\kappa | s] + \delta S_{1122}[\kappa | s] + \kappa^2\{2\delta S_{1111}[\kappa | s^3] + \delta S_{1122}[\kappa | s^3]\}. \quad (7.6)$$

The function η is the viscometric viscosity, ϕ and ν are the normal stress functions and the $\delta S_{i_1, i_2}[\cdot]$ are linear functionals whose nature has been explored by Pipkin and Owen [6].

Now, we turn to the determination of $\omega(r)$ and $u(r)$ by examining two cases.

(i) *Poiseuille-torsional flow.* Note that τ_1 as given by (7.1) is simply $\eta u'$ and thus it follows that the velocity profile $u(r)$ is the same as in the viscometric, Poiseuille flow.

(ii) *Helical-torsional flow.* If the outer tube is suspended, then the axial force acting on it can be measured. This gives b , since the axial force per unit length is given by (6.13):

$$2\pi R_2(b/R_2 - \frac{1}{2}aR_2), \quad (7.7)$$

where R_2 is the outer radius of the cylindrical tube.

Elsewhere [7] the author has conjectured on the basis of reasonable physical grounds that the value of the linear functional

$$\delta S_{2323}[\kappa | s^2] = -\frac{1}{2}\nu. \quad (7.8)$$

If one neglects the contributions to τ_1 and τ_2 from $f(\kappa, s)$ in (7.1) and (7.2) and used (7.8), one obtains:

$$\tau_1 = \eta u' + \frac{(\phi - \nu)cr^2\omega}{r^2\omega'^2 + u'^2} (r^2\omega'^2 - u'^2) = \frac{b}{r} - \frac{ar}{2}, \quad (7.9)$$

$$\tau_2 = \eta r\omega' + \frac{(\phi - \nu)cr u'}{r^2\omega'^2 + u'^2} (u'^2 - r^2\omega'^2) + \frac{\nu}{2} cru' = \frac{M}{2\Pi r^2}. \quad (7.10)$$

Thus (7.9) and (7.10) lead to two highly nonlinear differential equations for determining $\omega(r)$ and $u(r)$. These will have to be solved numerically, subject to the conditions

$$u(R_i) = 0 (i = 1, 2); \quad \omega(R_2) = \Omega_2, \quad \omega(R_1) = \Omega_1. \quad (7.11)$$

The reader's attention is drawn to the fact that even under drastic simplifications, the material functions τ_1 and τ_2 are not related as in the helical flow.

Finally, if a simpler constitutive equation such as the BKZ fluid [15] is used, one would have obtained [7]

$$\tau_1 = \eta u' + (\phi - \nu)cr^2\omega', \quad (7.12)$$

$$\tau_2 = \eta r\omega' + \left(\phi - \frac{\nu}{2}\right)cr u'. \quad (7.13)$$

While the differential equations (7.9) and (7.10) are somewhat simplified by using (7.12) and (7.13), the solution is still to be sought numerically.

8. The helical flow combined with axial motion of fanned planes. Turning to (5.8), one can see that the following velocity field

$$\dot{r} = 0, \quad \dot{\theta} = \omega(r), \quad \dot{z} = u(r) + c\theta, \quad (8.1)$$

is a MWCSH of type (ii), occurring in a cylindrical polar coordinate system.² The physical components of the acceleration field associated with (8.1) are:

$$a\langle r \rangle = -\omega^2 r, \quad a\langle \theta \rangle = 0, \quad a\langle z \rangle = c\omega, \quad (8.2)$$

and it is easy to see that the equations of motion (5.12) are solved, by inserting the inertia terms $\rho a\langle r \rangle$, $\rho a\langle \theta \rangle$ and $\rho a\langle z \rangle$ in (6.12)₁, (6.12)₂ and (6.13)₃ respectively and by choosing

$$\begin{aligned} \phi &= -az + h(r), \\ T_E\langle rz \rangle &= -\frac{1}{2}ar + br^{-1} + r^{-1} \int_A^r \rho c R \omega(R) dR, \quad A > 0, \end{aligned} \quad (8.3)$$

$$h'(r) = \rho r \omega^2 + (d/dr)T_E\langle rr \rangle - (1/r)\Sigma_1.$$

Note that Σ_1 appears in (8.3)₃ because the tensor \mathbf{L} has a matrix form (6.1) with $\kappa l = r\omega'$, $\kappa m = u'$ and $\kappa n = cr$. Thus, from (6.3)₁ it follows that for the flow (8.1),

$$\begin{aligned} \Sigma_1 &= T_E\langle \theta\theta \rangle - T_E\langle rr \rangle, \\ \Sigma_2 &= T_E\langle zz \rangle - T_E\langle rr \rangle, \\ \tau_1 &= T_E\langle r\theta \rangle, \quad \tau_2 = T_E\langle rz \rangle, \quad \tau_3 = T_E\langle \theta z \rangle. \end{aligned} \quad (8.4)$$

² The axial motion of fanned planes, described by $\dot{r} = \dot{\theta} = 0$, $\dot{z} = c\theta$, is a discovery of Pipkin [12].

Hence we have demonstrated that the helical flow superposed on the axial motion of fanned planes is dynamically possible in an incompressible simple fluid, and further no inertia terms have been neglected.

9. A simplified form of the constitutive equation for MWCSH of type (ii). It was established earlier that if the motion be a MWCSH of type (ii) and (3.15) is not satisfied, then the constitutive equation is

$$\mathbf{T} + p\mathbf{1} = \mathbf{T}_E = f(\mathbf{A}_1, \mathbf{A}_2). \quad (9.1)$$

Now, a full of expansion of (9.1) contains eight terms if the term involving $\mathbf{1}$ is absorbed into the pressure function p .

For the Poiseuille-torsional flow, (3.15) can never be satisfied because $m = r\omega'/\kappa$ is zero. Thus (9.1) holds always for this flow. In addition, for this motion the number of terms in the expansion of (9.1) can be reduced to six [7] and thus we obtain:

$$\mathbf{T}_E = \alpha_1\mathbf{A}_1 + \alpha_2\mathbf{A}_1^2 + \alpha_3\mathbf{A}_2 + \alpha_4\mathbf{A}_2^2 + \alpha_5(\mathbf{A}_1\mathbf{A}_2 + \mathbf{A}_2\mathbf{A}_1) + \alpha_6(\mathbf{A}_1^2\mathbf{A}_2^2 + \mathbf{A}_2^2\mathbf{A}_1^2), \quad (9.2)$$

where the α_i ($i = 1, \dots, 6$) are analytic functions of the invariants of \mathbf{A}_1 and \mathbf{A}_2 , which were given originally by Rivlin [17]. The interesting feature of (9.2) is that it can be shown to hold for the flow in the Maxwell rheometer as well [7], [18], [19] and [20].

Similarly, it can be shown that when (3.15) holds, the constitutive equation is given by [7]:

$$\mathbf{T}_E = \beta_1\mathbf{A}_1 + \beta_2\mathbf{A}_1^2 + \beta_3\mathbf{A}_2 + \beta_4\mathbf{A}_2^2 + \beta_5\mathbf{A}_3 + \beta_6\mathbf{A}_3^2, \quad (9.3)$$

where the β_j ($j = 1, \dots, 6$) depend on the appropriate invariants of \mathbf{A}_1 , \mathbf{A}_2 and \mathbf{A}_3 [7, 21].

The general method of proving (9.2) (or (9.3)) consists in showing that the combinations of kinematical tensors appearing in (9.2) (or (9.3)) are such that the operator \mathcal{L} defined by:

$$[\mathcal{L}][\mathbf{M}] = [\mathbf{A}] \quad (9.4)$$

is nonsingular. In (9.4), \mathbf{M} is the "column vector" consisting of the following six symmetric tensors:

$$[\mathbf{M}_1] = \begin{vmatrix} 1 & 0 & 0 \\ 0 & 0 & 0 \\ 0 & 0 & 0 \end{vmatrix} \quad [\mathbf{M}_2] = \begin{vmatrix} 0 & 0 & 0 \\ 0 & 1 & 0 \\ 0 & 0 & 0 \end{vmatrix} \quad [\mathbf{M}_3] = \begin{vmatrix} 0 & 0 & 0 \\ 0 & 0 & 0 \\ 0 & 0 & 1 \end{vmatrix} \quad (9.5)$$

$$[\mathbf{M}_4] = \begin{vmatrix} 0 & 1 & 0 \\ 1 & 0 & 0 \\ 0 & 0 & 0 \end{vmatrix} \quad [\mathbf{M}_5] = \begin{vmatrix} 0 & 0 & 1 \\ 0 & 0 & 0 \\ 1 & 0 & 0 \end{vmatrix} \quad [\mathbf{M}_6] = \begin{vmatrix} 0 & 0 & 0 \\ 0 & 0 & 1 \\ 0 & 1 & 0 \end{vmatrix} \quad (9.6)$$

and \mathbf{A} is the "column vector" consisting of $\mathbf{A}_1, \dots, (\mathbf{A}_1\mathbf{A}_2^2 + \mathbf{A}_2^2\mathbf{A}_1), (\mathbf{A}_1^2\mathbf{A}_2^2 + \mathbf{A}_2^2\mathbf{A}_1^2)$ (or $\mathbf{A}_1, \dots, \mathbf{A}_3^2$).

10. Concluding remarks. This paper has explored the kinematics of a class of MWCSH and suggested approximately realizable experiments to measure the material functions occurring in such flows. It is clear that one way of estimating these non-viscometric material functions is to treat the flows discussed here as nearly viscometric flows in the sense of Pipkin and Owen [6]. Such an attempt has been made and described elsewhere [7] in full detail, while a selected list of results was presented in Sec. 7 here.

Acknowledgment. The research reported here was sponsored by the Mathematics Research Center, United States Army, Madison, Wisconsin, under Contract No. DA-31-124-ARO-D-462. I wish to thank Professors M. W. Johnson, Jr., A. S. Lodge and J. B. Rosser for constructive criticisms and suggestions.

REFERENCES

- [1] W. Noll, *Motions with constant stretch history*, Arch. Rational Mech. Anal. 11, 97-105 (1962)
- [2] B. D. Coleman, *Kinematical concepts with applications in the mechanics and thermodynamics of incompressible viscoelastic fluids*, Arch. Rational Mech. Anal. 9, 273-300 (1962)
- [3] C.-C. Wang, *A representation theorem for the constitutive equation of a simple material in motions with constant stretch history*, Arch. Rational Mech. Anal. 20, 329-340 (1965)
- [4] C. Truesdell and W. Noll, *The non-linear field theories of mechanics*, Handbuch der Physik, Band III/3, Springer-Verlag, Berlin, 1965, pp. 1-602
- [5] W.-L. Yin and A. C. Pipkin, *Kinematics of viscometric flow*, Div. Appl. Math., Brown Univ. Technical Report No. 1, 1969
- [6] A. C. Pipkin and D. R. Owen, *Nearly viscometric flows*, Phys. Fluids 10, 836-843 (1967)
- [7] R. R. Huilgol, *On the construction of motions with constant stretch history II: Motions superposable on simple extension and various simplified constitutive equations for constant stretch histories*, M.R.C. Technical Report No. 975, Univ. of Wisconsin, Madison, Wis., 1969; parts of this report appear in Trans. Soc. Rheol. 14, 425-437 (1970)
- [8] W. Noll, *A mathematical theory of the mechanical behavior of continuous media*, Arch. Rational Mech. Anal. 2, 198-226 (1958)
- [9] B. D. Coleman and W. Noll, *Steady extension of incompressible simple fluids*, Phys. Fluids 5, 840-843 (1962)
- [10] G. H. Hardy, J. E. Littlewood and G. Polya, *Inequalities*, Cambridge Univ. Press, New York, (1934), 2nd ed., 1952
- [11] W. Noll, *On the continuity of the solid and fluid states*, J. Rational Mech. Anal. 4, 3-81 (1955)
- [12] A. C. Pipkin, *Controllable viscometric flows*, Quart. Appl. Math. 26, 87-100 (1968)
- [13] R. R. Huilgol, *On the construction of motions with constant stretch history. I: Superposable viscometric flows*, M.R.C. Technical Report 954, Univ. of Wisconsin, Madison, Wis., 1968
- [14] J. G. Oldroyd, *Some steady flows of the general elastico-viscous liquid*, Proc. Roy. Soc. London, Ser. A 283, 115-133 (1965)
- [15] B. D. Coleman and W. Noll, *Helical flow of general fluids*, J. Appl. Phys. 30, 1508-1512 (1959)
- [16] B. Bernstein, E. A. Kearsley and L. J. Zapas, *A study of stress relaxation with finite strain*, Trans. Soc. Rheology 7, 391-410 (1963)
- [17] R. S. Rivlin, *Further remarks on the stress-deformation relations for isotropic materials*, J. Rational Mech. Anal. 4, 681-702 (1955)
- [18] B. Maxwell and R. P. Chartoff, *Studies of a polymer melt in an orthogonal rheometer*, Trans. Soc. Rheology 9, 41-52 (1965)
- [19] R. B. Bird and E. K. Harris, Jr., *Analysis of steady state shearing and stress relaxation in the Maxwell orthogonal rheometer*, A. I. Ch. E. J. 14, 758-761 (1968)
- [20] R. R. Huilgol, *On the properties of the motion with constant stretch history occurring in the Maxwell rheometer*, Trans. Soc. Rheology (to appear)
- [21] A. J. M. Spencer and R. S. Rivlin, *The theory of matrix polynomials and its application to the mechanics of isotropic continua*, Arch. Rational Mech. Anal. 2, 309-336 (1958/59)