

## EQUATIONS IN A FREE $\mathbf{Q}$ -GROUP

O. KHARLAMPOVICH AND A. MYASNIKOV

ABSTRACT. An algorithm is constructed that decides if a given finite system of equations over a free  $\mathbf{Q}$ -group has a solution, and if it does, finds a solution.

### 0. INTRODUCTION

Systems of equations over a group have been widely studied (see, for instance, [4],[5],[11]). This is currently one of the main streams of combinatorial group theory. The problem of deciding if a system of equations in a group has a solution is a generalization of the word and conjugacy problems. Makanin [8] and Razborov [11] proved one of the most significant results in this area: the algorithmic solvability of systems of equations in free groups. Rips and Sela [12] solved equations over hyperbolic groups by reducing the problem to free groups. Myasnikov and Remeslennikov proved that the universal theory is decidable over free  $A$ -groups, where  $A$  is an integral domain of characteristic 0 and  $\mathbf{Z}$  is a pure subgroup of  $A$ .

If  $\mathbf{Z}$  is not a pure subgroup of  $A$  then the structure of a free  $A$ -group is much more complicated. It turned out (see [3]) that the crucial case is  $A = \mathbf{Q}$ . Baumslag [1] proved that the word problem is decidable in free  $\mathbf{Q}$ -groups. In [6] we proved that the conjugacy problem in these groups is decidable.

A subring  $C$  of the ring  $\mathbf{Q}$  is said to be *recursive* if there is an algorithm which decides whether a given rational number belongs to  $C$ . Any subring of  $\mathbf{Q}$  is of the form  $\mathbf{Q}_\pi$ , i.e. generated by the set  $\{\frac{1}{p} \mid p \in \pi\}$ , where  $\pi$  is a set of primes. It is not difficult to see that the recursive subrings of  $\mathbf{Q}$  are exactly the rings  $\mathbf{Q}_\pi$  for recursive subsets  $\pi$ . If the set  $\pi$  is not recursive then the Diophantine problem over a free  $\mathbf{Q}_\pi$ -group  $F^{\mathbf{Q}_\pi}$  is undecidable. Indeed, let  $a \in F^{\mathbf{Q}_\pi}$  be an element which  $\mathbf{Q}_\pi$ -generates its own centralizer in  $F^{\mathbf{Q}_\pi}$  (i.e. if  $1 \neq a = b^r$ , then  $r$  is invertible in  $\mathbf{Q}_\pi$ ); then an equation  $x^p = a$  has a solution in  $F^{\mathbf{Q}_\pi}$  if and only if  $p \in \pi$ .

The main result of this paper is the following.

**Theorem 1.** *Let  $\pi$  be a recursive set of primes. Then there exists an algorithm that decides if a given finite system of equations over a free  $\mathbf{Q}_\pi$ -group has a solution, and if it does, finds a solution.*

In particular, the Diophantine problem over a free  $\mathbf{Q}$ -group  $F^{\mathbf{Q}}$  is decidable.

Let  $A$  be an arbitrary ring of characteristic 0 with a prime subring  $\mathbf{Z}$ . The additive isolator  $Is_A(\mathbf{Z}) = \{a \in A \mid \exists n(na \in \mathbf{Z})\}$  of  $\mathbf{Z}$  in  $A$  is a subring of  $A$  which

---

Received by the editors April 5, 1996.

1991 *Mathematics Subject Classification.* Primary 20E05, 20F10.

The first author was supported by grants from NSERC and FCAR; the second author was supported by the NSF Grant DMS-9103098.

©1998 American Mathematical Society

is embeddable in  $\mathbf{Q}$ . Therefore,  $Is_A(\mathbf{Z}) = \mathbf{Q}_{\pi(A)}$ , where  $\pi(A)$  is the set of all prime integers which are invertible in  $A$ .

Theorem 1 and approximation results from [3] imply the following fact.

**Theorem 2.** *Let  $A$  be a ring of characteristic 0 with identity 1. Then an algorithm that decides if a given finite system  $W = 1$  of equations with coefficients in  $F$  has a solution in a free  $A$ -group  $F^A$  exists if and only if the set  $\pi(A)$  is recursive. Moreover, if  $W = 1$  has a solution, the algorithm finds one.*

In particular, for any field  $K$  of characteristic 0 the Diophantine problem with coefficients in  $F$  over  $F^K$  is decidable.

In order to solve a system of equations in a free  $\mathbf{Q}_\pi$ -group, we develop some methods to reduce a system of equations in such a group to a finite set of systems in a free group. The reduction guarantees that for every so-called “minimal” solution of the system in the free  $\mathbf{Q}_\pi$ -group, there exists a solution to at least one of the systems in the free group satisfying certain conditions restricting the range of values of the unknowns, and for every such solution to one of the systems in the free group there exists a corresponding solution for the original system in the free  $\mathbf{Q}_\pi$ -group. Since by [8], [7] and [11] it is possible to decide if a system of equations in a free group has a solution (satisfying certain restrictions), this reduction allows one to decide if the system over the free  $\mathbf{Q}_\pi$ -group has a solution. This idea was used for the first time in [12]. Notice that a system of equations over a free  $\mathbf{Q}_\pi$ -group is equivalent to a system of equations (over the free  $\mathbf{Q}_\pi$ -group) with coefficients that lie in the free group with the same set of generators. Notice also that a free  $\mathbf{Q}_\pi$ -group is a direct limit of hyperbolic groups [6], but this does not help us directly. Indeed, if a solution of the system exists in the free  $\mathbf{Q}_\pi$ -group then it belongs to some member of the union (direct limit), so to some hyperbolic group, but we do not know which member.

We can prove the same result as Theorem 1 for a tensor  $\mathbf{Q}_\pi$ -completion of an arbitrary torsion-free hyperbolic group, but a lot of additional work is required. With a view to proving the more general result in a subsequent paper, we formulate most of the notions and lemmas in this paper in more general terms than are required for proving Theorem 1.

Let  $G$  be a torsion-free hyperbolic group with generators  $d_1, \dots, d_N$ . We will consider a finite system of equations over the  $\mathbf{Q}_\pi$ -group  $G^{\mathbf{Q}_\pi}$  (see the definition in the next section). By adding a finite number of new variables and new equations we can reduce this system to a system with coefficients in  $G$  (indeed, every constant of the form  $d^{m/n}$  can be replaced by a new variable  $z$  satisfying the equation  $z^n = d^m$ ). We also can replace this system by an equivalent system of triangular equations (every equation contains no more than three terms). We will consider now a finite system of triangular equations with coefficients in  $G$ :

$$(1) \quad \phi_i(d_1, \dots, d_N, x_1, \dots, x_L) = 1$$

## 1. $A$ -GROUPS

Let  $A$  be an arbitrary associative ring with identity and  $G$  a group. Fix an action of the ring  $A$  on  $G$ , i.e. a map  $G \times A \rightarrow G$ . The result of the action of  $\alpha \in A$  on  $g \in G$  is written as  $g^\alpha$ . Consider the following axioms:

1.  $g^1 = g, g^0 = 1, 1^\alpha = 1$ ;
2.  $g^{\alpha+\beta} = g^\alpha \cdot g^\beta, g^{\alpha\beta} = (g^\alpha)^\beta$ ;

- 3.  $(h^{-1}gh)^\alpha = h^{-1}g^\alpha h$ ;
- 4.  $[g, h] = 1 \implies (gh)^\alpha = g^\alpha h^\alpha$ .

**Definition 1.** Groups with  $A$ -actions satisfying axioms 1)–4) are called  $A$ -groups.

In particular, an arbitrary group  $G$  is a  $\mathbf{Z}$ -group. We now recall the definition of  $A$ -completion.

**Definition 2.** Let  $G$  be a group. Then an  $A$ -group  $G^A$  together with a homomorphism  $G \rightarrow G^A$  is called a *tensor  $A$ -completion* of the group  $G$  if  $G^A$  satisfies the following universal property: for any  $A$ -group  $H$  and a homomorphism  $\varphi : G \rightarrow H$  there exists a unique  $A$ -homomorphism  $\psi : G^A \rightarrow H$  (a homomorphism that commutes with the action of  $A$ ) such that the following diagram commutes:

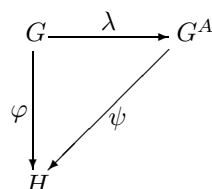

It was proved in [2] that for every group  $G$  the tensor  $\mathbf{Q}_\pi$ -completion of  $G$  exists and is unique; in [9] this fact was proved for an arbitrary ring  $A$ .

We describe below the  $\mathbf{Q}_\pi$ -completion  $G^{\mathbf{Q}_\pi}$  of a torsion-free hyperbolic group  $G$  as the union of an effective chain of hyperbolic subgroups (details can be found in [6]).

An element  $v$  of a group is called a *primitive* element if it is not a proper power.

Let  $\mathbf{Z}_\pi$  be the multiplicative submonoid of  $\mathbf{Z}$  generated by the set  $\pi$ ,  $\mathbf{Z}_\pi = \{m_1, m_2, \dots\}$ , where  $m_1 < m_2 < \dots$ . For an arbitrary torsion-free hyperbolic group  $R$  and natural number  $n \geq 2$ , choose a set of elements  $\mathcal{V}_n = \{v_1 \dots v_t\} \in R$  satisfying the following condition ( $S_n$ ):

- 1)  $\mathcal{V}_n$  consists of cyclically minimal (of minimal length in its conjugacy class) primitive elements of length not more than  $m_n$ ;
- 2) no two centralizers in the set of centralizers  $\{C(v), v \in \mathcal{V}_n\}$  are conjugate in  $R$ ;
- 3) the set  $\mathcal{V}_n$  is maximal with properties 1) and 2), i.e. any element of length not more than  $m_n$  is conjugate to a power of some  $v \in \mathcal{V}_n$ .

By definition,

$$(2) \quad R(\mathcal{V}_n) = (\dots (R *_{v_1=w_1^{m_n}} \langle w_1 \rangle) *_{v_2=w_2^{m_n}} \langle w_2 \rangle) * \dots *_{v_t=w_t^{m_n}} \langle w_t \rangle).$$

Notice that this definition does not depend on the order of elements in  $\mathcal{V}_n$ .

It was proved in [6] that  $G^{\mathbf{Q}_\pi}$  is the union of a chain of hyperbolic groups

$$G = T_0 < T_1 < T_2 < \dots < \bigcup_{n=0}^{\infty} T_n,$$

with  $T_n = T_{n-1}(\mathcal{V}_n)$ , where  $\mathcal{V}_n$  satisfies the condition  $S_n$  in the group  $T_{n-1}$ .

**Definition 3.** Let a group  $H$  be an amalgamated product  $H = S *_{w=tr} \langle t \rangle$ . Then  $t$ -syllables of the word  $b_0 t^{\alpha_1} b_1 t^{\alpha_2} \dots b_n$ , where  $b_j \in S$ , are the subwords  $t^{\alpha_1}, \dots, t^{\alpha_n}$ . If  $u$  is an element in  $H$ , then  $|u|_H$  is the number of occurrences of  $\langle t \rangle$ -syllables in a reduced word representing  $u$ . We call this number the  $t$ -length of  $u$ .

Any finite set of elements  $\{g_1, \dots, g_n\}$  in  $G^{\mathbf{Q}^\pi}$  is contained in some subgroup  $H$  that is obtained from the group  $G$  by adding a finite number of roots. It is the union of a chain of subgroups  $H_i$ . The groups  $H_i$  together with a canonical set of generators are defined below. Let  $G = H_0$ .

1. Step 1. Consider pairwise nonconjugated cyclically minimal primitive elements  $u_1, \dots, u_{k_1} \in G$ ,  $|u_1| \leq \dots \leq |u_{k_1}|$  (here  $|u|$  denotes the length of  $u$  in  $G$ ), and add roots  $t_1, \dots, t_{k_1}$  such that  $u_j = t_j^{s_j}$ . (Notice that  $u_{i+1}$  does not become a proper power after we add roots  $t_1, \dots, t_i$ .) The corresponding groups are denoted by  $H_1, \dots, H_{k_1}$ , where  $H_{j+1} = H_j *_{u_{j+1}=t_{j+1}^{s_{j+1}}} \langle t_{j+1} \rangle$ .
2. Step 2. Consider pairwise nonconjugated primitive elements  $u_{k_1+1}, \dots, u_{k_2} \in H_1$ , cyclically reduced in the amalgamated product, each having the reduced form  $u = t_1^{\alpha_1} c_1 \dots t_1^{\alpha_k} c_k$ , where  $\alpha_i \neq 0, \alpha_i \in \mathbf{Z}, c_i \in G$ ,  $|u_{k_1+1}|_{H_1} \leq \dots \leq |u_{k_2}|_{H_1}$ ; and add roots  $t_{k_1+1}, \dots, t_{k_2}$ , such that  $u_j = t_j^{s_j}$ , to the group  $H_{k_1}$ . The corresponding groups are denoted by  $H_{k_1+1}, \dots, H_{k_2}$ , where  $H_{j+1} = H_j *_{u_{j+1}=t_{j+1}^{s_{j+1}}} \langle t_{j+1} \rangle$ .
3. Step  $i + 1$ . Suppose that  $H_1, \dots, H_{k_i}$  have been constructed.

Consider pairwise nonconjugated primitive elements  $u_{k_i+1}, \dots, u_{k_{i+1}} \in H_i$ , cyclically reduced in the amalgamated product, each having the following reduced form  $t_i^{\alpha_1} c_1 \dots t_i^{\alpha_k} c_k$ , where  $\alpha_i \neq 0, \alpha_i \in \mathbf{Z}, c_i \in H_{i-1}$  ( $c_k$  is not a power of  $u_i$ , because the elements are cyclically reduced),  $|u_{k_i+1}|_{H_i} \leq \dots \leq |u_{k_{i+1}}|_{H_i}$ , and add roots  $t_{k_i+1}, \dots, t_{k_{i+1}}$ , such that  $u_j = t_j^{s_j}$ , to the group  $H_{k_i}$ . The corresponding groups are denoted by  $H_{k_i+1}, \dots, H_{k_{i+1}}$ , where  $H_{j+1} = H_j *_{u_{j+1}=t_{j+1}^{s_{j+1}}} \langle t_{j+1} \rangle$ .

Finally, for some number  $i$  one has  $H = H_{k_{i+1}}$ .

The canonical set of generators of  $H_0 = G$  is  $\{d_1, \dots, d_N\}$ : the canonical set of generators of  $H_{j+1}$  is defined inductively as the union of the canonical set of generators of  $H_j$  and  $t_{j+1}$ .

The group  $H_{k_{i+1}}$  is called the *group at level  $i$* , corresponding to the sequence  $u_1, \dots, u_{k_{i+1}}$ . The group  $H_i$  will be called the *group of rank  $i$* . We also order the set of  $t_j$ 's:  $t_k < t_l$  if  $k < l$ .

Let  $F$  be the free group with the same set of generators as  $G$  and  $F_{k_j+p} = F * K_{k_j+p}$ , where  $j \leq i$  and  $K_{k_j+p}$  is the free group with the generators  $t_1, \dots, t_{k_j+p}$ . Let  $\pi$  be the natural homomorphism of  $F_{k_i+p}$  onto  $H_{k_i+p}$ . If  $v \in F_j$ , then by  $\tilde{v}$  we denote  $\pi(v) \in H_j$ .

## 2. DIAGRAMS

Recall that a *map* is a finite, planar, connected 2-complex.

By a *diagram  $\Delta$  over a presentation  $\langle a_1, \dots, a_m | R_1, \dots, R_n \rangle$* , where the words  $R_i$  are cyclically reduced, we mean a map with a function  $\phi$  which assigns to each edge of the map one of the letters  $a_k^{\pm 1}$ ,  $1 \leq k \leq m$ , such that  $\phi(e^{-1}) = (\phi(e))^{-1}$  and if  $p = e_1 \dots e_d$  is the contour of some cell  $\Phi$  of  $\Delta$ , then  $\phi(p) = \phi(e_1) \dots \phi(e_d)$  in the free group  $F(a_1, \dots, a_m)$  is a cyclic shift of one of the defining words  $R_i^{\pm 1}$ . In general the word  $\phi(p)$  is called the *label* of the path  $p$ . The label of a diagram  $\Delta$  (whose contour is always taken with a counterclockwise orientation) is defined analogously.

Van Kampen's Lemma states that a word  $W$  represents the identity of the group  $G$  if and only if there is a simply connected (or Van Kampen, or disk) diagram  $\Delta$  over  $G$  such that the boundary label of  $\Delta$  is  $W$ .

Suppose we have a diagram over  $H_j$ . A  $t_j$ -strip is a subdiagram with the boundary label  $t_j^{s_j^n} u_j^{-n}$  (see Figure 1(a)), consisting of cells with the boundary  $t_j^{s_j} u_j^{-1}$  (see Figure 1(b)). Two  $t_j$ -strips can be glued together to form a *paired  $t_j$ -strip* (see Figure 1(c)). More than two  $t_j$ -strips can be glued together to form a  $t_j$ -star (see Figure 1(d)).

Every minimal (with minimal number of  $t_j$ -cells) diagram over  $H_j$  consists of paired  $t_j$ -strips,  $t_j$ -stars,  $t_j$ -strips on the boundary and  $H_{j-1}$ -subdiagrams between them (annular paired  $t_j$ -strips can be assumed not to occur). Suppose we have a  $H_{k_i}$ -diagram. Notice that for  $i \leq j, l \leq k_i$ ,  $t_j$ -stars,  $t_l$ -stars, and paired strips cannot meet as in Figure 1(e), because  $u_i, \dots, u_{k_i}$  do not contain  $t_i, \dots, t_{k_i}$ .

For every word  $w$  which represents the identity element in  $H_{k_i}$  there is a diagram over  $H_{k_i}$  with the boundary label  $w$  that has the form shown in Figure 1(f). If it consists of glued  $t_j$ -strips, and  $t_j$ -strips on the boundary for  $j \in \{i, \dots, k_i\}$ , and  $H_{i-1}$ -subdiagrams between them.

### 3. SOME PROPERTIES OF THE CAYLEY GRAPH OF $H$

A generating set  $J$  of  $H = H_{k_{i+1}}$  consists of  $d_1, \dots, d_N$  and the added roots  $t_1, \dots, t_{k_{i+1}}$ . Recall that the vertices of the Cayley graph  $\Gamma(H) = \Gamma(H, J)$  are elements of  $H$ ; and two vertices  $g, h$ , are connected by an edge  $e = (g, d)$ , with label  $\phi(e) = d \in J$ , if  $h = gd$ .

**Definition 4.** Let  $u$  be a cyclically reduced word in  $H_i$ . A word  $X$  is called a *u-periodic word* if it is a subword of some power  $u^k$ .

**Lemma 1.** Let  $p, s \in H_{i-1}$ , let  $u, v \in F_i$  be words representing the reduced forms of elements  $\tilde{u}, \tilde{v} \in \{u_{k_{i+1}}, \dots, u_{k_{i+1}}\}$ , let  $X, Y$  be  $u$ - and  $v$ -periodic words respectively, and let  $s\tilde{X}p = \tilde{Y}$ .

If  $\tilde{u} \neq \tilde{v}$ , then  $|\tilde{X}|_{H_i}, |\tilde{Y}|_{H_i} < |\tilde{u}|_{H_i} + |\tilde{v}|_{H_i} + 2$ .

If  $\tilde{u} = \tilde{v}$  and  $X, Y$  begin and end with  $t_i$  belonging to distinct  $\langle t_i \rangle$ -syllables of  $u$ ,  $s \neq 1$ , then  $|\tilde{X}|_{H_i}, |\tilde{Y}|_{H_i} \leq |\tilde{u}|_{H_i}$ .

If  $\tilde{u} = \tilde{v}$ ,  $X, Y$  begin and end with  $t_i$  belonging to the same  $\langle t_i \rangle$ -syllables of  $u$ ,  $s \neq 1$ , then  $s = u_i^\beta, p = u_i^\gamma$  in  $H_i$  and the canonical image of  $t_i^{\beta s_i} X t_i^{\gamma s_i}$  equals the canonical image of  $Y$  in  $H_{i-1} * \langle t_i \rangle$ .

*Proof.* We will prove the first assertion of the lemma. Suppose  $|\tilde{v}|_{H_i} \geq |\tilde{u}|_{H_i}$ . Taking a cyclic permutation of  $u$  instead of  $u$  and a cyclic permutation of  $v$  instead of  $v$ , we can suppose that  $X$  starts with  $u$ ,  $Y$  starts with  $v$ ,  $\tilde{u} = a_0 t_i^{\beta_1} a_1 \dots t_i^{\beta_n} a_n$ ,  $0 < \beta_k < s_i$  for all  $k$ , and  $\tilde{v} = s(a_0 t_i^{\beta_1} a_1 \dots t_i^{\beta_n} a_n)^c a_0 \dots t_i^{\beta_m} b$ .

Suppose that  $|\tilde{X}|_{H_i} \geq |\tilde{u}|_{H_i} + |\tilde{v}|_{H_i} + 2$ . The case  $\bar{\beta}_m < \beta_m$  is impossible, because it implies  $\beta_1 = \beta_m = \beta_m - \bar{\beta}_m$ . We have

$$(3) \quad \begin{aligned} & b s a_0 t_i^{\beta_1} a_1 \dots t_i^{\beta_n} a_n a_0 t_i^{\beta_1} a_1 t_i^{\beta_2} \dots \\ & = a_m t_i^{\beta_{m+1}} a_{m+1} \dots t_i^{\beta_n} a_n a_0 t_i^{\beta_1} a_1 \dots a_{m+1} t_i^{\beta_{m+2}} \dots \end{aligned}$$

Now instead of  $a_r, r < n$ , we write  $\bar{a}_r$  and instead of  $a_0 a_n$  we just write  $\bar{a}_n$ . We have  $\beta_j = \beta_{j+m}$  for any  $j$  (indices are taken modulo  $n$ ). These equations for powers imply  $a_0 \neq 1$  or  $a_n \neq 1$ . Let  $d = (n, m)$ ; then this implies that  $\beta_j = \beta_{j+d}$  (indices are taken

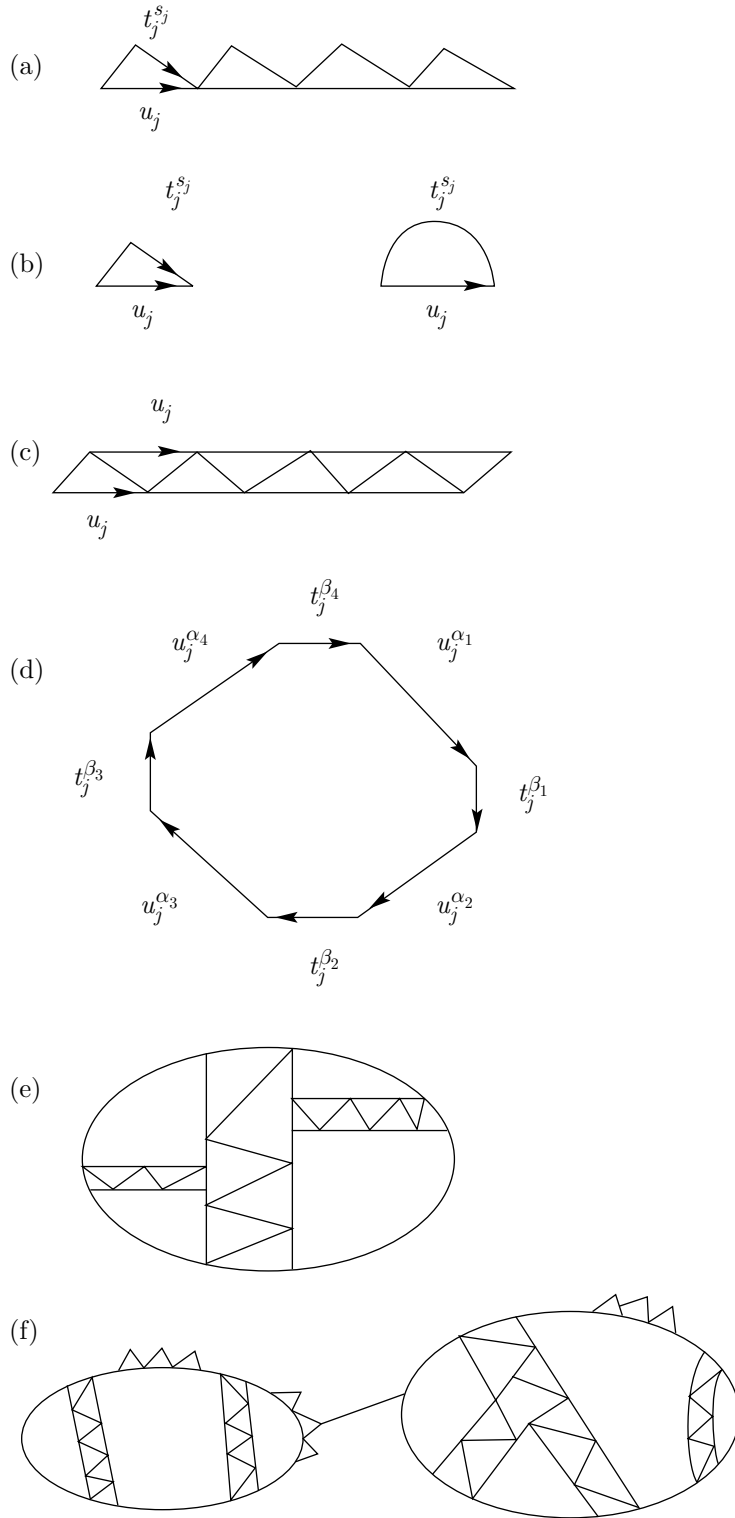

FIGURE 1

modulo  $n$ ). We also have from equation (3)  $bsa_0 = a_m u_i^{\alpha_0}$ ,  $u_i^{\alpha_{j-1}} \bar{a}_j = \bar{a}_{m+j} u_i^{\alpha_j}$ ,  $j = 1, \dots, n$  (the subscripts of the  $\bar{a}$ 's are taken modulo  $n$ ). Then  $\alpha_n = \alpha_0$ , because  $u_i^{\alpha_0} \bar{a}_1 = \bar{a}_{m+1} u_i^{\alpha_1}$  and  $u_i^{\alpha_n} \bar{a}_1 = \bar{a}_{m+1} u_i^{\alpha_{n+1}}$  and the subgroup  $\langle u_i \rangle$  is malnormal. Hence

$$u_i^{\alpha_0} a_1 \dots t_i^{\beta_n} a_n a_0 t_i^{\beta_1} u_i^{-\alpha_0} = a_{m+1} \dots t_i^{\beta_n} a_n a_0 t_i^{\beta_1} a_1 \dots a_m t_i^{\beta_{m+1}}.$$

We have for some  $\beta$  and  $\gamma$ ,  $u_i^\beta \bar{a}_d = \bar{a}_n u_i^\gamma$ . We also have  $\sum_k \alpha_{j+dk} = 0$ . And  $\tilde{u}$  is the  $(n/d)$ -th power of the element  $a_0 t_i^{\beta_1} \dots t_i^{\beta_d} u_i^{-\beta} a_n = a_0 t_i^{\beta_1} \dots t_i^{\beta_d} a_d u_i^{-\gamma}$ . Then  $\tilde{v}$  is also a proper power.

In the case  $m = 0$ ,  $|\tilde{v}|_{H_i} > |\tilde{u}|_{H_i}$ , we have  $\tilde{v} = s(a_0 t_i^{\beta_1} a_1 \dots t_i^{\beta_n} a_n)^c b$  and

$$(4) \quad bsa_0 t_i^{\beta_1} a_1 \dots t_i^{\beta_n} a_n a_0 t_i^{\beta_1} a_1 t_i^{\beta_2} \dots = a_0 t_i^{\beta_1} a_1 \dots t_i^{\beta_n} a_n a_0 t_i^{\beta_1} a_1 t_i^{\beta_2} \dots.$$

Then  $bsa_0 = a_0 u_i^{\alpha_0}$  and  $u_i^{\alpha_{j-1}} \bar{a}_j = \bar{a}_j u_i^{\alpha_j}$ . This implies that  $\alpha_0 = 0$  and  $b = s^{-1}$ , and  $\tilde{v}$  is conjugated to a power of  $\tilde{u}$ .

In the case  $|\tilde{v}|_{H_i} = |\tilde{u}|_{H_i}$ , we have  $\tilde{v} = sa_0 t_i^{\beta_1} a_1 \dots t_i^{\beta_n} a_n b$  and

$$bsa_0 t_i^{\beta_1} a_1 \dots t_i^{\beta_n} a_n bsa_0 t_i^{\beta_1} a_1 t_i^{\beta_2} \dots = a_0 t_i^{\beta_1} a_1 \dots t_i^{\beta_n} a_n a_0 t_i^{\beta_1} a_1 t_i^{\beta_2} \dots,$$

and again  $b = s^{-1}$  and  $\tilde{u}$  and  $\tilde{v}$  are conjugated.

The second and third assertions of the lemma can be proved similarly.

**Corollary 1.** *Let  $p, s \in H_{i-1}$  and  $\tilde{u}, \tilde{v} \in \{u_{k_i+1}, \dots, u_{k_{i+1}}\}$ ,  $\tilde{u} \neq \tilde{v}$ ,  $|\tilde{v}|_{H_i} \geq |\tilde{u}|_{H_i}$ . Let  $X, Y$  be  $u$ - and  $v$ -periodic words respectively and  $sXp = Y$ . Then  $|\tilde{X}|_{H_i}, |\tilde{Y}|_{H_i} < 3|\tilde{v}|_{H_i}$ .*

This follows directly from the lemma in the case  $|\tilde{v}|_{H_i} > 1$ . If  $|\tilde{v}|_{H_i} = |\tilde{u}|_{H_i} = 1$ , then taking cyclic permutations of  $u, v$  instead of  $u$  and  $v$ , we have  $\tilde{u} = a_0 t^\beta a_1$ ,  $\tilde{v} = sa_0 t^\beta b_1$ . If  $|\tilde{X}|_{H_i} = |\tilde{Y}|_{H_i} \geq 3$ , then

$$sa_0 t_i^\beta a_1 a_0 t_i^\beta a_1 a_0 t_i^\beta \dots = sa_0 t_i^\beta b_1 sa_0 t_i^\beta b_1 sa_0 t_i^\beta \dots.$$

Hence  $a_1 a_0 = b_1 sa_0 u_i^{\alpha_0}$ ,  $u_i^{\alpha_0} a_1 a_0 = b_1 sa_0 u_i^{\alpha_1}$  for some  $\alpha_0, \alpha_1 \in \mathbf{Z}$ . Then  $\alpha_0 = \alpha_1 = 0$ ,  $a_1 a_0 = b_1 sa_0$  and  $\tilde{u} = \tilde{v}$ , a contradiction.

**Definition 5.** An element in  $H_{i+r}$  is said to be written in *reduced form in rank  $i$*  if it belongs to  $H_i$  and is in reduced form as an element in the amalgamated product  $H_i = H_{i-1} *_{u_i=t_i^{s_i}} \langle t_i \rangle$ . If  $r = 0$ , then the element is said to be in reduced form in all ranks  $\geq i$  if it is in reduced form in rank  $i$ . An element  $h$  in  $H_{i+r}$  is defined by induction on  $r$  to be written in *reduced form in all ranks  $\geq i$*  if it is written in reduced form in the amalgamated product  $H_{i+r} = H_{i+r-1} *_{u_{i+r}=t_{i+r}^{s_{i+r}}} \langle t_{i+r} \rangle$ ,  $h = b_0 t_{i+r}^{\alpha_1} b_1 t_{i+r}^{\alpha_2} \dots b_n$ , where the  $b_1, \dots, b_n \in H_{i+r-1}$  are in reduced form in all ranks  $\geq i$ .

**Definition 6.** A  $\langle t_i \rangle$ -*syllable of a path* is a subpath labelled by some  $\langle t_i \rangle$ -syllable of the label of the path.

**Definition 7.** A  $u$ -*path* is a path labelled by a  $u$ -periodic word.

**Definition 8.** Let  $\tilde{u}, \tilde{v} \in \{u_{k_i+1}, \dots, u_{k_{i+1}}\}$ ,  $|\tilde{u}|_{H_i} \geq |\tilde{v}|_{H_i}$ . Consider in  $\Gamma(H)$  two paths: a  $u$ -path  $r_1$  and a  $v$ -path  $r_2$ , where  $r_1$  connects the sequence of vertices

$$\dots, g\tilde{u}^{-2}, g\tilde{u}^{-1}, g, g\tilde{u}, g\tilde{u}^2, \dots,$$

$r_2$  connects the sequence of vertices

$$\dots, gh\tilde{v}^{-2}, gh\tilde{v}^{-1}, gh, gh\tilde{v}, gh\tilde{v}^2, \dots,$$

the label of every subpath of  $r_1$  or  $r_2$  is a reduced word in  $H_i$ , and  $h \in H_{k_i}$ . Then a path  $q$  that connects  $r_1$  with  $r_2$  is called a *minimal path* if

1.  $\phi(q)$  represents an element in reduced form in all ranks greater than or equal to  $i$ ,
2. the number of  $\langle t_i \rangle$ -syllables in  $\phi(q)$  is minimal for all paths connecting  $r_1$  with  $r_2$ .

**Lemma 2.** *Let  $r_1$  and  $r_2$  be the paths from Definition 8,  $h \in H_{k_i}$ . Then there are two possibilities:*

1.  *$h$  contains some  $t_j$  that is greater than or equal to  $t_i$ . Then there are a uniquely determined number  $s_1$  and consecutive  $\langle t_i \rangle$ -syllables  $z_1, z_2$  and  $z_3$  of the subpath of  $r_1$ , with the label  $u$ , between  $g\tilde{u}^{s_1}$  and  $g\tilde{u}^{s_1+2}$ , such that the initial points of all the minimal paths connecting  $r_1$  with  $r_2$  belong to the subpath of  $r_1$  joining  $z_1$  with  $z_3$ . (And, similarly, there are a uniquely determined number  $s_2$  and consecutive  $\langle t_i \rangle$ -syllables  $z_4, z_5$  and  $z_6$  of the subpath of  $r_2$ , with the label  $v$ , between  $gh\tilde{v}^{s_2}$  and  $gh\tilde{v}^{s_2+2}$ , such that the terminal points of all the minimal paths connecting  $r_1$  with  $r_2$  belong to the subpath of  $r_2$  joining  $z_4$  with  $z_6$ .)*
2.  *$h$  does not contain any  $t_j$  that is greater than or equal to  $t_i$ . Then either the same conclusion is true as in the previous case, or, for any two paths  $q$  and  $q'$  connecting  $r_1$  with  $r_2$  and such that  $|q|_{H_i} = |q'|_{H_i} = 0$ , we have the equality  $\pi\phi(q^{-1})\tilde{X}\pi\phi(q') = \tilde{Y}$ , where  $X$  is a  $u$ - and  $Y$  is a  $v$ -periodic word corresponding to the subpaths of  $r_1$  and  $r_2$  connecting the initial and terminal points of  $q$  and  $q'$  respectively. Then  $|\tilde{X}|_{H_i}, |\tilde{Y}|_{H_i} \leq |\tilde{u}|_{H_i} + |\tilde{v}|_{H_i} + 1$ .*

The numbers  $s_1, s_2$  above do not depend on  $g$ .

*Proof.* The assertion of the lemma in the second case follows directly from Lemma 1.

To prove the assertion in the first case, suppose that  $q$  and  $\bar{q}$  are two minimal paths connecting  $r_1$  with  $r_2$ . Let  $p_1, \bar{p}_1$  be their initial points and  $p_2, \bar{p}_2$  their terminal points. We have to prove that each of the paths  $p_1\bar{p}_1$  and  $p_2\bar{p}_2$  contains at most one  $\langle t_i \rangle$ -syllable.

Consider a minimal diagram  $\Theta$ , with contour consisting of the subpath of  $r_1$  between the points  $p_1$  and  $\bar{p}_1$ , the path  $\bar{q}$ , the subpath of  $r_2^{-1}$  between  $\bar{p}_2$  and  $p_2$ , and the path  $q^{-1}$ .

Every subpath of  $r_1$  or  $r_2$  is reduced (i.e. has a reduced label), and the elements  $q$  and  $\bar{q}$  are reduced; hence there cannot be  $t_j$ -arcs and  $t_j$ -stars with two ends on the same side of  $\Theta$ , as in Figure 2(a), for  $j \geq i$ . The diagram  $\Theta$  has the form shown in Figure 2(b), where the strips are paired  $t_j$ -strips for  $j \geq i$ , the 3-ended stars are  $t_i$ -stars and the regions between the strips and stars must be  $H_{i-1}$  subdiagrams. Hence the paths  $p_1\bar{p}_1$  and  $p_2\bar{p}_2$  cannot contain more than one  $t_i$ -syllable each.

The lemma is proven.

The lemma immediately implies the following result.

**Corollary 2.** *Let  $\tilde{u} = u_{k_i+p}, h \in H_{k_i+p-1}$ . Consider in  $\Gamma(H)$  two  $u$ -paths  $r_1$  and  $r_2$ , where  $r_1$  connects the sequence of vertices*

$$\dots, g\tilde{u}^{-2}, g\tilde{u}^{-1}, g, g\tilde{u}, g\tilde{u}^2, \dots,$$

*$r_2$  connects the sequence of vertices*

$$\dots, gh\tilde{u}^{-2}, gh\tilde{u}^{-1}, gh, gh\tilde{u}, gh\tilde{u}^2, \dots,$$



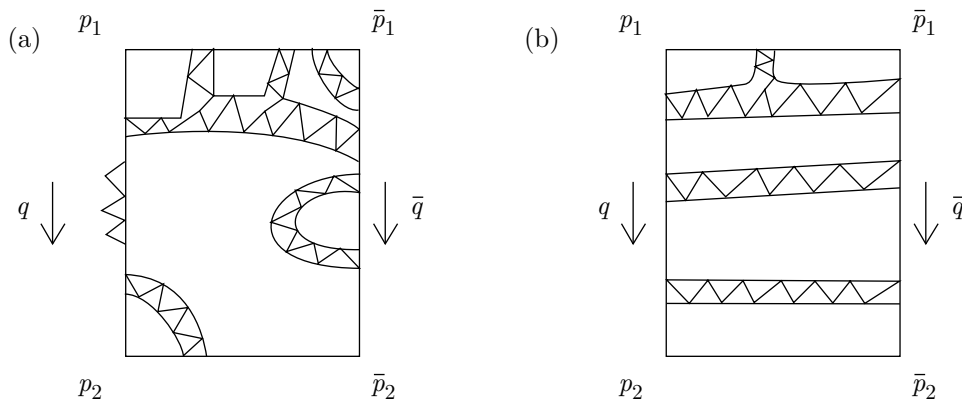

FIGURE 2

and every subpath of  $r_1$  or  $r_2$  is labelled by a reduced word in  $H_i$ .

Then there are uniquely determined numbers  $s_1, s_2$ , such that for every path  $\bar{q}$  connecting some  $g\tilde{u}^{s_3}$  with  $gh\tilde{u}^{s_4}$

1.  $\phi(\bar{q}) = \phi(q_1)\phi(q)\phi(q_2)$ , where  $q_1$  is a  $u$ -path connecting  $g\tilde{u}^{s_3}$  with some vertex  $p_1$  on the subpath of  $r_1$  joining  $g\tilde{u}^{s_1}$  and  $g\tilde{u}^{s_1+3}$  (see Figure 3),  $q$  is a path connecting  $p_1$  with a vertex  $p_2$  on the subpath of  $r_2$  joining  $gh\tilde{u}^{s_2}$  and  $gh\tilde{u}^{s_2+3}$ ,  $q_2$  is a  $u$ -path connecting  $p_2$  with  $gh\tilde{u}^{s_4}$ ,
2.  $q$  is reduced in all ranks  $j \geq i$ , and
3. the sum of  $t_i$ -lengths of pieces of  $q$  between  $\langle t_j \rangle$ -syllables, for  $j > i$ , is minimal for all paths  $q$  with the above property.

These numbers  $s_1, s_2$  and the labels of the paths  $q_1, q, q_2$  depend only on  $h$  and  $u$ , and not on  $g$ .

There is a uniquely determined number  $s_1$  such that, for every path  $\bar{q}$  connecting some vertex  $g$  with  $ghu^{s_3}$ ,

1.  $\phi(\bar{q}) = \phi(q_3)\phi(q_4)$ , where  $q_4$  connects  $g$  with some vertex  $p_1$  on the subpath of  $r_2$  joining  $g\tilde{u}^{s_1}$  and  $g\tilde{u}^{s_1+3}$ ,  $q_4$  is a  $u$ -path connecting  $p_1$  with  $gh\tilde{u}^{s_3}$ ,
2.  $q_3$  is reduced in all ranks  $j \geq i$ , and
3. the sum of  $t_i$ -lengths of pieces of  $q_3$ , between  $\langle t_j \rangle$ -syllables for  $j > i$ , is minimal for all paths  $q_3$  with the above property.

This number  $s_1$  and the labels of the paths  $q_3, q_4$  do not depend on  $g$ .

The label of the path  $q$  satisfying the conditions of this corollary will be called a  $(u, u)$ -pseudoconnector for  $h$ , the label of the path  $q_3$  will be called a  $u$ -pseudoconnector for  $h$ . Notice that all elements of the form  $u^k h u^s$  have the same  $(u, u)$ -pseudoconnectors and all the elements of the form  $h u^s$  have the same  $u$ -pseudoconnectors.

**Definition 9.** In this definition we keep the notation of the corollary. A *connecting zone* for the element  $h$  is defined as follows. Consider a path  $q$  labelled by a  $(u, u)$ -pseudoconnector for  $h$ . Consider the two phase vertices  $b_1$  and  $b_2$  closest to  $p_2$  on either side of  $p_2$  on the  $u$ -path  $r_2$ , with the property that the path from  $p_2$  to  $b_j$  has  $t_i$ -length at least one. (If  $p_2$  is not a phase vertex, then  $b_1 = gh\tilde{u}^{s_2}$ ,  $b_2 = gh\tilde{u}^{s_2+k}$ , where  $k$  is either 1 or 2; if  $p_2$  is a phase vertex, then  $b_1 = gh\tilde{u}^{s_2-1}$  and  $b_2 = gh\tilde{u}^{s_2+1}$ .)

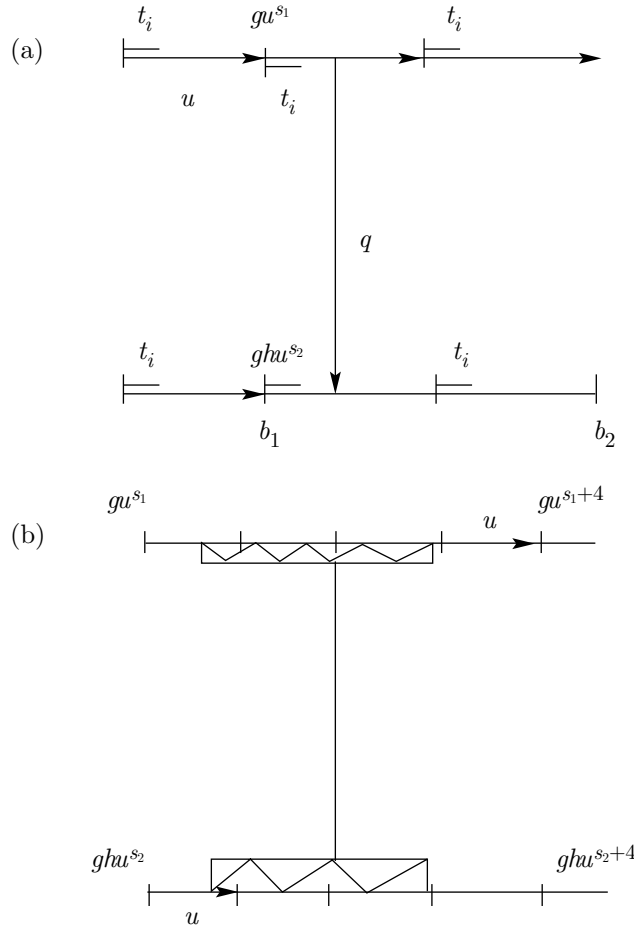

FIGURE 3

The connecting zone for  $h$  with respect to  $g$  is the union of all phase vertices between such  $b_1$  and  $b_2$  for all  $(u, u)$ -pseudoconnectors ( $u$ -pseudoconnectors) for  $h$ ; see Figure 3(a). (Sometimes the connecting zone can consist of five phase vertices; they are shown in Figure 3(b).)

If the vertex  $gh\tilde{u}^s$  belongs to the connecting zone for  $h$  with respect to  $g$ , then the vertex  $g_1h\tilde{u}^s$  belongs to the connecting zone for  $h$  with respect to  $g_1$ . If it is clear from the context what the initial vertex  $g$  of the path labelled by  $h$  is (or if it does not matter), then we denote by  $(h)_1$  and  $(h)_2$  the initial and terminal vertices of the connecting zone for  $h$  with respect to  $g$ , and will talk about the connecting zone for  $h$  without mentioning the initial point  $g$ .

4. CONSTRUCTION OF CANONICAL REPRESENTATIVES

We will define a section  $\beta : H_{k_i+p} \rightarrow F_{k_i+p}$  (a mapping of sets such that  $\pi \circ \beta = id$ ). For  $X \in H_{k_i+p}$  we call  $\beta(X)$  the *canonical representative* of  $X$ .

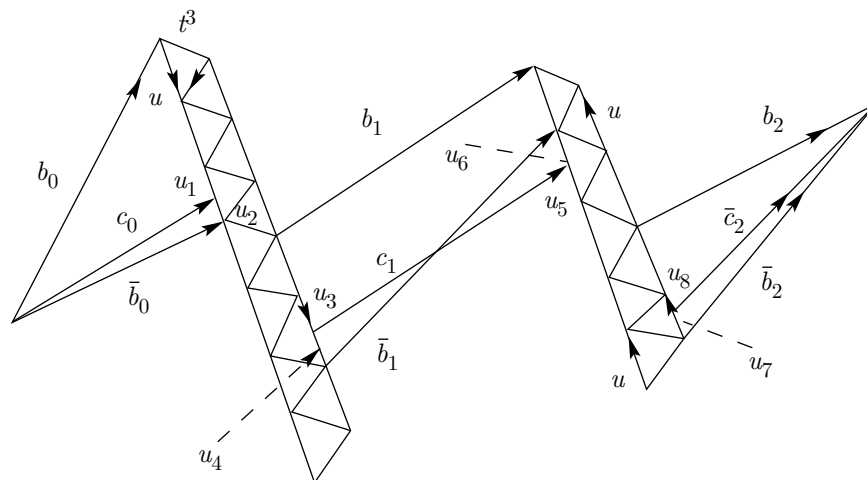

FIGURE 4

The canonical representative of an element in  $G$  is just some fixed geodesic word representing this element. (If  $G$  is a free group, then it is the reduced word representing this element.) Suppose we have already constructed representatives for all elements in  $H_{k_i+p-1}$ . Now take an element  $X$  in  $H_{k_i+p}$  that contains  $t_{k_i+p}$  and construct a representative of this element in  $F_{k_i+p}$ . The representative of  $X$  will be a word (or a label of a path in  $\Gamma(H_{k_i+p})$ ) corresponding to a reduced form of  $X$  in rank  $k_i + p$ . For each syllable  $b$  of this element between two consecutive  $\langle t_{k_i+p} \rangle$ -syllables we will denote the canonical representative of the label of a path connecting the vertices  $(b^{-1})_2$  and  $(b)_2$  by  $\bar{b}$  (see Figure 4). Suppose  $X = b_0 t^{\alpha_1} b_1 t^{\alpha_2} \dots b_n$ . Take some path labelled by  $X$  in  $\Gamma(H_{k_i+p})$ . The path corresponding to  $\bar{b}_i$  connects the points  $(b_i^{-1})_2$  and  $(b_i)_2$ . Then the points  $(b_{i-1})_2$  and  $(b_i^{-1})_2$  can be connected by a path with the label  $t_{i_k+p}^{\gamma_i}$ . Then the canonical representative for  $X$  is  $\bar{b}_0 t_{i_k+p}^{\gamma_1} \bar{b}_1 t_{i_k+p}^{\gamma_2} \dots \bar{b}_n$ .

**Definition 10.** Let  $\tilde{u} = u_{k_i+p}$ ,  $h \in H_{k_i+p-1}$ ,  $h$  an element from Corollary 2. The  $(u, u)$ -connector (resp. a  $u$ -connector) for the element  $h$  is the canonical representative of the label of a path, reduced in ranks  $i, \dots, k_i + p - 1$ , connecting the vertex  $(h^{-1})_2$  (resp.  $g$ ) with  $(h)_2$ .

Let  $\tilde{u} = u_j, \tilde{v} = u_k, j < k, j, k \in \{i + 1, \dots, k_{i+1}\}$ , and suppose that  $q$  connects some vertex  $g\tilde{u}^{s_1}$  with  $gh\tilde{v}^{s_2}, h \in H_i$ . Consider the point  $(h)_2$  (the terminal point of the path labelled by the  $v$ -connector for  $h$ ). Let the path  $p$  connect  $(h)_2$  with  $g\tilde{u}^{s_1}$ . Consider the point  $(\phi(p)^{-1})_2$  (the terminal point of the path labelled by the  $u$ -connector for  $\phi(p)^{-1}$ ). The  $(u, v)$ -connector for  $h$  is the canonical representative of the label of a path in  $H_i$  connecting  $(\phi(p)^{-1})_2$  with  $(h)_2$ .

It is important that the elements  $u_j$  that do not belong to  $G$  be chosen in such a way that  $\beta(u_{k_i+p}^n) = (\beta(u_{k_i+p}))^n$ . For this we first take connectors for  $u_{k_i+p}^n$  and then, if necessary, replace  $u_{k_i+p}$  by its cyclic permutation starting with  $t_i$ . (If  $G$  is a free group then this equality can be made true for all  $u_i$ 's.) Below, all the elements  $u_j$  will always be represented by the words  $\beta(u_j)$ , and we will write  $u_j$  instead of  $\beta(u_j)$ . It will be clear from the context when  $u_i$  means a word and when it means the element represented by this word.

In Figure 4 we considered the following example. Denote  $t_{k_i+p}$  by  $t$  and  $u_{k_i+p}$  by  $u$ . Let  $u = t^3$ ,  $X = b_0 t^{11} b_1 t^{-7} b_2$  and  $u = u_1 u_2 = u_3 u_4 = u_5 u_6 = u_7 u_8$  in  $H_i$ . Let  $b_0 = c_0 u_1^{-1} u^{-2}$ , where  $c_0$  is a pseudoconnector for  $b_0$ ,  $b_1 = u u_3 c_1 u_6 u$ , where  $c_1$  is a pseudoconnector for  $b_1$ ,  $b_2 = u^{-1} u_8^{-1} c_2$ , where  $c_2$  is a pseudoconnector for  $b_2$ . Let  $\bar{b}_k$  ( $k = 0, 1, 2$ ) be a connector corresponding to  $b_k$ . In this example,  $\beta(X) = \beta(\bar{b}_0) t^8 \beta(\bar{b}_1) t^{-10} \beta(\bar{b}_2)$ .

5. MIDDLES

Let  $X = \{X_1, \dots, X_L\}$  be a solution of system (1) in the group  $G^{\mathbb{Q}\pi}$ . Suppose this solution contains the least possible number of roots. Then for some  $i$  this solution belongs to the group  $H_{k_{i+1}} = H$ . Let  $\tau_i(X)$  be the sum of the numbers of  $t_i$ -syllables in all  $X_1, \dots, X_L$ . Denote  $\tau(X) = (\tau_1(X), \dots, \tau_{k_{i+1}}(X))$ . Let  $X < Y$  if  $\tau(X) < \tau(Y)$ . Let  $X = \{X_1, \dots, X_L\}$  be a minimal solution with respect to this order.

By an *equational triangle* (resp. *equational diagram*) we mean a triangular equation  $XYZ = 1$  (resp. an equation  $X_1 \dots X_n = 1$ ) together with a solution  $A, B, C$  (resp.  $A_1, \dots, A_n$ ) and a diagram over  $H$  having  $\beta(A)\beta(B)\beta(C)$  (resp.  $\beta(A_1) \dots \beta(A_n)$ ) as its boundary label. A *system of equational diagrams* is a system of equations together with the system of diagrams, such that the solution associated to each equational diagram must be a solution of the whole system.

For the solution  $X_1, \dots, X_L$  of system (1) we will construct another solution  $X'_1, \dots, X'_L$  and a system of equations over the group  $G * K_{k_{i+1}}$  (if  $G = F$ , then  $G * K_{k_{i+1}} = F_{k_{i+1}}$ ), such that  $\beta(X'_1), \dots, \beta(X'_L)$  will be a part of a solution of this new system, and every solution of the new system will give a solution of system (1).

Denote  $u_{k_i+p}$  by  $u$  and  $t_{k_i+p}$  by  $t$ .

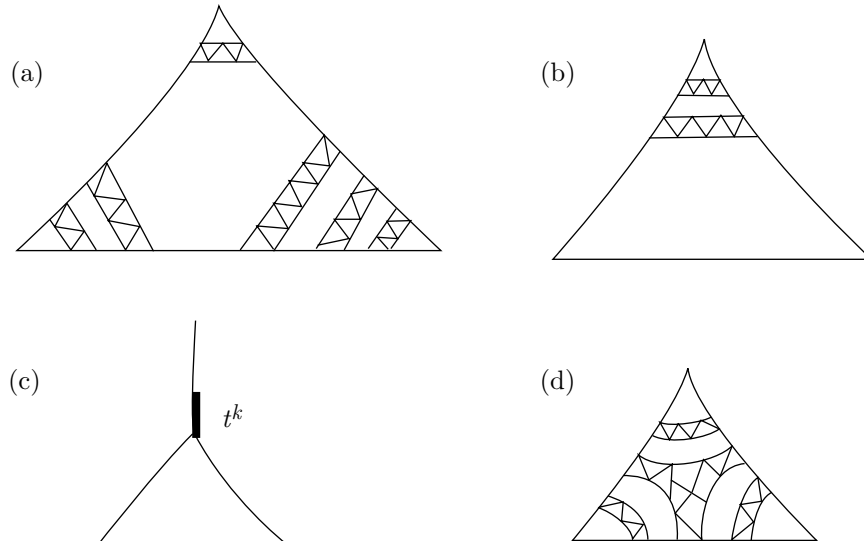

FIGURE 5

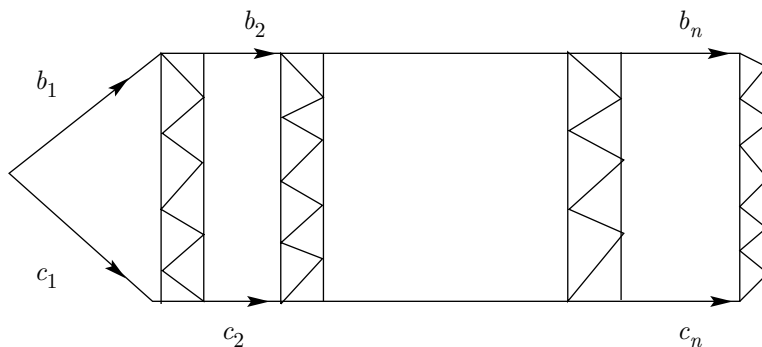

FIGURE 6

Consider an equational triangle in  $H_{k_i+p}$  with at least one side label containing  $t$  (hence at least two side labels containing  $t$ ). It is represented by a diagram in the form shown in Figure 5 (we showed only  $t_j$ -strips for  $t_j = t$ ).

**Lemma 3.** *Suppose that in  $H_{k_i+1}$  we have a diagram (see Figure 6) with the boundary label  $(b_1 t_{j_1}^{r_{j_1}} \dots t_{j_n}^{r_{j_n}} b_n t_{j_{n+1}}) t_{j_{n+1}}^{r_{j_{n+1}}} (c_1 t_{j_1}^{p_{j_1}} \dots t_{j_n}^{p_{j_n}} c_n t_{j_{n+1}})^{-1}$ , where  $j_1, \dots, j_{n+1} \in \{k_i + 1, \dots, k_{i+1}\}$ ,  $b_1, c_1, \dots, b_n, c_n \in H_{k_i}$ . Then  $\beta(b_1 t_{j_1}^{r_{j_1}} \dots t_{j_n}^{r_{j_n}} b_n t_{j_{n+1}}) t_{j_{n+1}}^{r_{j_{n+1}}} = \beta(c_1 t_{j_1}^{p_{j_1}} \dots t_{j_n}^{p_{j_n}} c_n t_{j_{n+1}})$  in  $F_{k_{j+1}}$ .*

This assertion follows immediately from the choice of canonical representatives.

It follows from Lemma 3 that every equational triangle either does not contain any cells or takes on one of the forms shown in Figure 7, and hence has a unique maximal nontrivial  $H_{k_i+p-1}$ -subdiagram.

**Definition 11.** Consider an equational triangle in  $\Gamma(H_{k_i+p})$  ( $p \geq 1$ ) with the boundary label  $\beta(X_1)\beta(X_2)\beta(X_3)$ . Suppose  $X_1$  contains  $t$ . Then the maximal nontrivial  $H_{k_i+p-1}$ -subdiagram of this triangle is called the *middle* of the triangle. (The subdiagrams  $ABCDEF$  (Fig. 7(a)),  $ABCD$  (Fig. 7(b)),  $ABC$  (Figure 7(c)) are middles.)

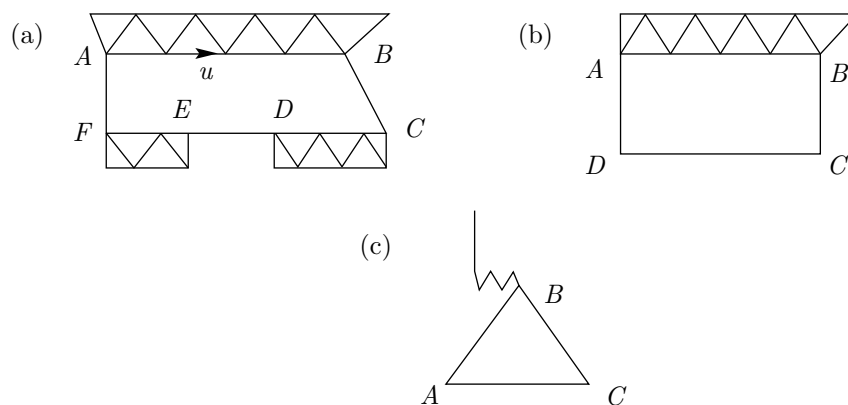

FIGURE 7

A boundary of a middle is canonically subdivided into paths; each of the paths either belongs to the  $u$ -side of a  $t$ -strip (is a  $u$ -path, joining two phase vertices) or is a connector. The  $u$ -paths are called *pseudoangles* of the middle. Every diagram over  $H_{k_i+p}$  can be embedded into  $\Gamma(H_{k_i+p})$ . A pseudoangle is *long* if the corresponding strippath is nontrivial and the connecting zones for two pseudoconnectors touching this pseudoangle do not intersect, and *short* if the corresponding strippath is nontrivial and the zones of two pseudoconnectors touching this pseudoangle intersect. A pseudoangle is *trivial* if the corresponding strippath is trivial. A middle is called *triangular* if all the pseudoangles are trivial; it is called *short* if it is not triangular and does not have long pseudoangles; otherwise it is long.

If none of the  $X_i$ 's contains  $t$ , then the middle of the triangle coincides with the triangle itself and is a *triangular middle*.

As an example, consider the middle  $ABCDEF$  in Figure 7(a). The paths  $AB, CD, EF$  are pseudoangles of this middle.

**Lemma 4.** *Consider an equational triangle over the group  $H_{k_i+p}, p \geq 1$ , and the middle of this triangle. Let  $AB, CD$  and  $EF$  be the pseudoangles of the middle (see Figure 7 (a)) and  $\phi(FA), \phi(BC), \phi(DE)$  be the connectors. Suppose  $\phi(AB) = u_{k_i+p}^n, n > 0$ . Then  $\beta(\phi(FA)\phi(AB)) = \phi(FA)\phi(AB)$ . If  $AB$  is a long pseudoangle and  $B_1$  is the left end of the zone for  $\phi(CB)$ , then  $A$  is the right end of the connecting zone for  $\phi(EA)$ ,  $B_1$  is the left end of the connecting zone for  $\phi(DB)$  and*

$$\beta(\phi(FA)\phi(AB_1)\phi(B_1C)) = \phi(FA)\phi(AB_1)\beta\phi(B_1C),$$

$$\beta(\phi(EA)\phi(AB_1)\phi(B_1C)) = \beta\phi(EA)\phi(AB_1)\beta\phi(B_1C),$$

$$\beta(\phi(FA)\phi(AB_1)\phi(B_1D)) = \phi(FA)\phi(AB_1)\beta\phi(B_1D),$$

$$\beta(\phi(EA)\phi(AB_1)\phi(B_1D)) = \beta\phi(EA)\phi(AB_1)\beta\phi(B_1D).$$

*Proof.* Let  $HGG_1H_1$  be the paired  $t_j$ -strip closest to the point  $A$ , and  $KLL_1K_1$  the paired  $t_{j_1}$ -strip closest to the point  $B$ ,  $j, j_1 > i$ . If there is no the strip  $HGG_1H_1$ , we just take  $F = H_1, E = G_1$ . If there is no strip  $KLL_1K_1$ , we take  $K = D, L = C$ . We show this case in Figure 8(a). There is no  $t_k$ -strip,  $k \geq i$ , connecting the paths  $H_1A$  and  $BL$ , because if there were, then from the description of representatives it would follow that  $A = B$ .

The label of the path  $FH$  is the beginning of the canonical representative for  $\phi(FB)$ . From the construction of representatives it follows that  $H_1A$  contains a  $\langle t_i \rangle$ -syllable; let  $PP_1$  be the  $\langle t_i \rangle$ -syllable closest to the vertex  $A$ . The path  $AB$  begins with a  $\langle t_i \rangle$ -syllable. Then  $P_1A$  is the last  $u_i$ -connector in  $u_{k_i+p}$ . It follows from the choice of  $u_{k_i+p}$  that  $P_1A$  connects these  $\langle t_i \rangle$ -syllables and connects the  $PP_1$ -syllable with the vertex  $A$  at the same time. So  $\phi(FA)\phi(AB)$  is the canonical representative of itself. Hence  $\beta(\phi(FA)\phi(AB)) = \phi(FA)\phi(AB)$ .

Because the pseudoangle  $AB$  is long, there should be at least two paired  $t_i$ -strips that begin on  $AB$  and end on  $ED$ , as in Figure 8(b). This implies that in the case when  $D \neq C$ , the left end of the connecting zone for  $\phi(DB)$  is  $B_1$ , and in the case when  $F \neq E$ , the right end of the connecting zone for  $\phi(EA)$  is  $A$ .

The four equalities follow by symmetry considerations from the first one. The lemma is proved.

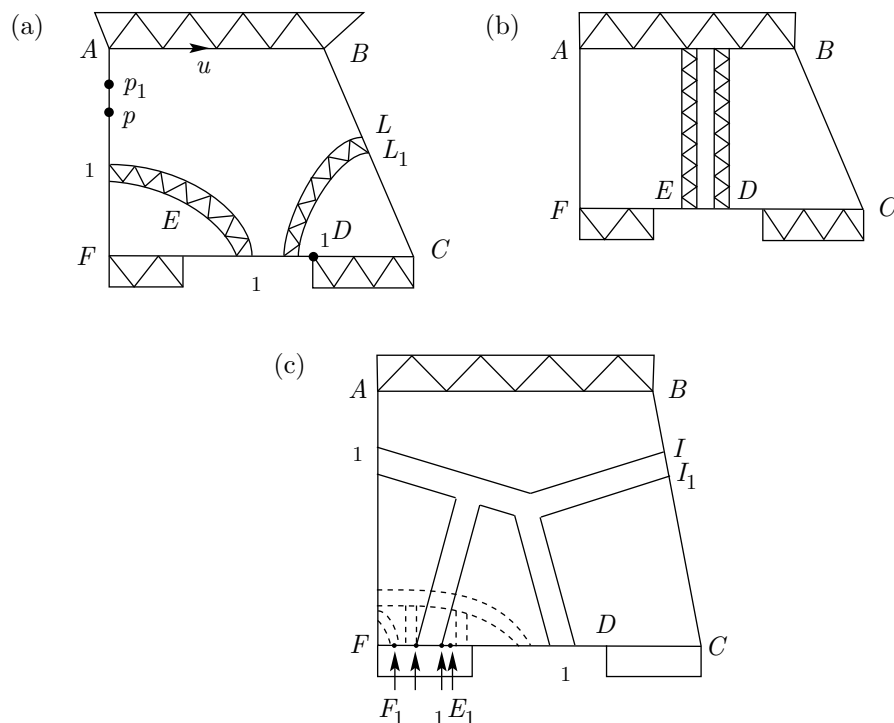

FIGURE 8

**Lemma 5.** Consider the diagram over the group  $H_{k_i+p}$ ,  $p \geq 1$ , shown in Fig. 7(a) or 7(b). Suppose the middle of this diagram is not triangular.

1. If all three connectors contain some  $t_j$ 's greater than  $t_i$ , then two pseudoangles are trivial.
2. If only two connectors contain some  $t_j$  greater than  $t_i$ , then one pseudoangle is trivial and another one is either trivial or short.
3. If none of the connectors contain a  $t_j$  greater than  $t_i$ , then two pseudoangles are either trivial or short.

*Proof.* Consider the middle shown in Fig. 7(a). Suppose there is a paired  $t_j$ -strip  $HGG_1H_1$  or a  $t_j$ -star  $HGG_1I_1IH_1$  for  $j > i$ , as shown in Fig. 8(c). Let this strip be the strip closest to  $FE$ . If  $j > k_i$  then by Lemma 3  $E = F$  and this pseudoangle is trivial. If  $j \leq k_i$ , then the path  $HG$  does not contain any  $t_k$  for  $k \geq i$ . Let  $E_1$  and  $F_1$  be the closest terminal points of  $(u_{k_i+p}, u_{k_i+p})$ -pseudoconnectors for  $\phi(DE)$  and  $\phi(AF)$  respectively. There are no paired  $t_i$ -arcs or  $t_i$ -stars as shown by broken lines in Fig. 8(c). Hence the path  $F_1E_1$  does not contain any  $t_i$ -syllable; hence  $F = E$ . If  $HGG_1H_1$  is a paired  $t_i$ -strip, then again the path  $HG$  does not contain  $t_i$ , and this implies  $F = E$ . If  $HH_1G_1GJ_1J$  is a  $t_i$ -star, then  $F_1$  and  $E_1$  must coincide, because  $AE_1$  is also a  $(u_{k_i+p}, u_{k_i+p})$ -pseudoconnector for  $AF$ . Now if all the three connectors contain some  $t_j$ 's greater than  $t_i$ , then either there are at least two paired strips for  $t_j$  and for  $t_{j_1}$ , as shown in Fig. 8(a), or there is a  $t_j$ -star. Then  $F = E$ ,  $D = C$ . So at least two pseudoangles are trivial.

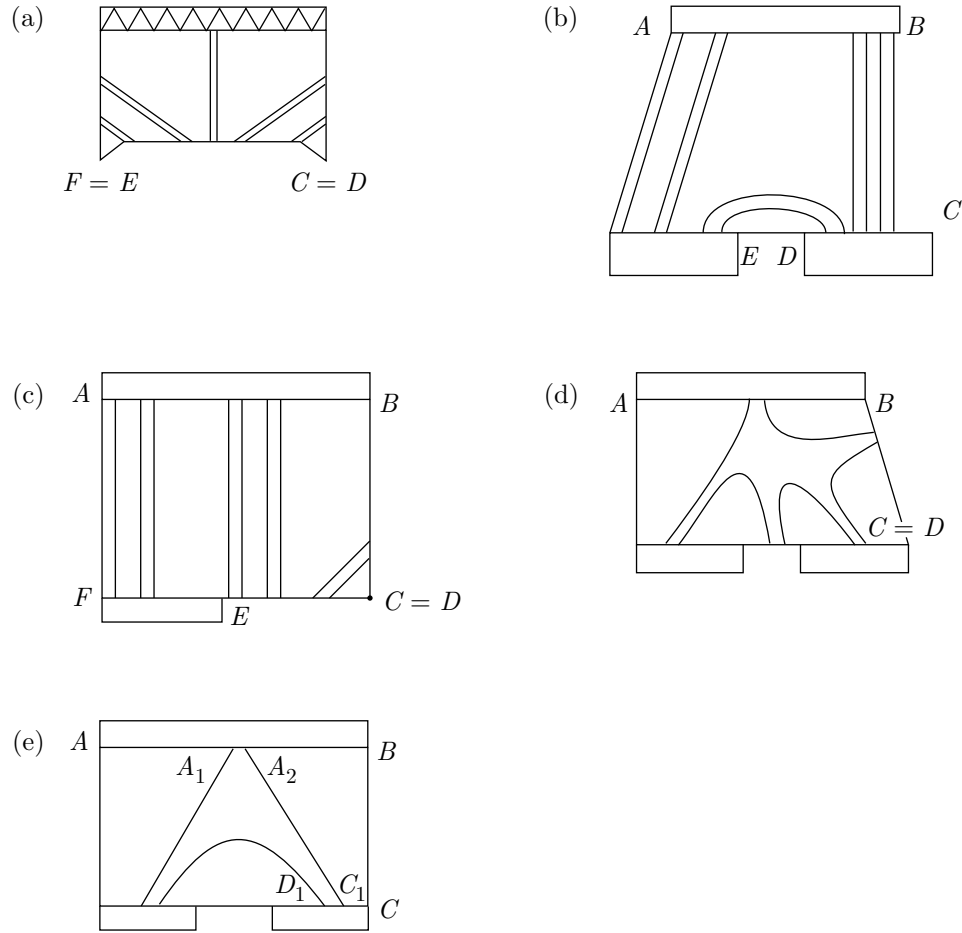

FIGURE 9

If only two connectors contain some  $t_j$  greater than  $t_i$ , then there is a paired  $t_j$ -strip  $HGG_1H_1$  closest to the vertex  $A$  as in Fig. 8(c); hence  $F = E$  and this pseudoangle is trivial. Suppose that the pseudoangle  $CD$  is nontrivial; the proof that it is short is similar to the proof of the third assertion, given below.

If none of the connectors contains a  $t_j$  greater than  $t_i$ , then there are no paired  $t_j$ -strips in the middle, and the  $t_i$ -strips are situated as in Fig. 9(a), 9(b), 9(c), 9(d), 9(e). In Fig. 9(a) the pseudoangles  $FE$  and  $DC$  are trivial, in Fig. 9(b) the pseudoangles  $FE$ ,  $AB$  and  $DC$  are short, in Fig. 9(c) the pseudoangle  $FE$  is short and  $DC$  is trivial, in Fig. 9(d) the pseudoangle  $FE$  is short and  $CD$  is trivial. In the case shown in Fig. 9(e) two pseudoangles are trivial and one is short. Indeed,  $A_1$  and  $A_2$  are both the beginnings of some  $(u_{k_i+p}, u_{k_i+p})$ -pseudoconnectors for  $BC$ , while  $D_1$  and  $C_1$  are both the beginnings of some  $(u_{k_i+p}, u_{k_i+p})$ -pseudoconnectors for  $CB$ .

The lemma is proved.



6. REDUCTION TO THE FREE GROUP

We start with a system  $S$  of  $M$  equational triangles in rank  $k_{i+1}$ . We will construct a system of equations in  $G * K_{k_{i+1}}$  such that the solution of  $S$  is a part of a solution of this system.

Consider in  $S$  an equational triangle with the boundary  $X_1X_2X_3$  corresponding to Figure 10. Recall that  $\beta(X_i) = X_i$  in  $F_{k_{i+1}}$ . Then

$$\begin{aligned} X_1 &= P_1Y_1(t^{s_{k_i+1}m_1+r_1})P_2, \\ X_2 &= P_2^{-1}t^{s_{k_i+1}m_2+r_2}Y_2^{-1}P_3^{-1}, \\ X_3 &= P_3Y_3P_1^{-1}, \\ Y_3 &= Y_4u^{-(m_1+m_2)}Y_1^{-1} \end{aligned}$$

in the group  $F_{k_{i+1}}$ , and we have to add the conditions that  $u \in F_i$ ,  $r_1 + r_2 = s_i$ , as well as the equational triangle over  $H_{k_{i+1}-1}$  with the boundary  $Y_4uY_2^{-1}$ .

**Definition 12.** A *free equational diagram* (resp. *triangle*) is an equational diagram (resp. triangle) with no cells.

The equational triangle with the boundary  $Y_4uY_2^{-1}$  over  $H_{k_{i+1}-1}$  is “non-free” (this means that the corresponding diagram might contain cells). We will say that the first three free equational diagrams are *free equational diagrams* (or *free equations*) of the *first type* and the fourth free equational diagram is a *free equational*

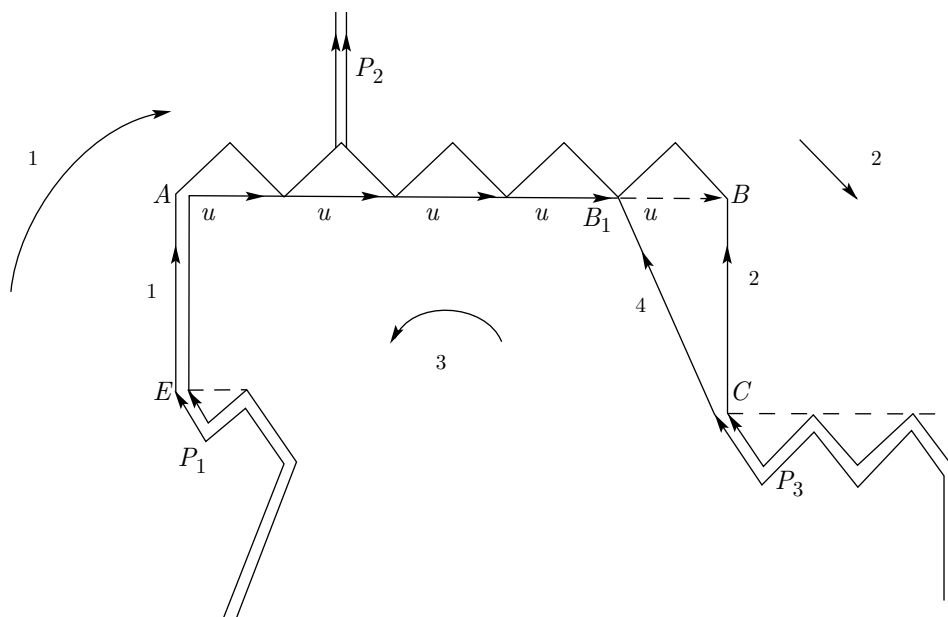

FIGURE 10

diagram (or free equation) of the second type. We also can rewrite free equational triangles in  $F_{k_{i+1}}$  in the form

$$\begin{aligned} X_1 &= P_1 Y_1 T^{m_1} T_1 P_2, \\ X_2 &= P_2^{-1} T^{m_2} T_2 (Y_2)^{-1} P_3^{-1}, \\ X_3 &= P_3 Y_3 P_1^{-1}, \\ Y_3 &= Y_4 u^{-(m_1+m_2)} Y_1^{-1} \end{aligned}$$

in the group  $F_{k_{i+1}}$ , and add equations

$$[T, t] = [T_1, t] = 1, \quad [T_2, t] = 1, \quad T_1 T_2 = T_1.$$

We also have to add the condition that  $u \in F_i$ .

Notice that the new “variables” in the non-free equational triangles are  $u$ , the connector  $Y_2$ , participating in the middle, and the canonical representative of the label of the path connecting  $C$  with the left end of the zone for  $\phi(CB)$  ( $\beta\phi(Y_2 u^{-1})$ ). Notice also that the freeness of the equational triangles of the first type implies that some of the  $Y$ ’s are the same. Below we will often use the fact that they will still have a solution in  $X$ ’s and  $P$ ’s if we replace some of the  $Y$ ’s by some other words.

We can rewrite every equational triangle in a similar way. We will obtain a system of free equations over  $F_{k_{i+1}}$  and a system of triangular equations over  $H_{k_{i+1}-1}$ . Denote the union of these systems by  $S_1$ . At the next step we repeat this process for the non-free equations over  $H_{k_{i+1}-1}$  with unknowns  $Y_i$ . Finally, after  $k_{i+1}$  steps we will obtain a system  $S_{k_{i+1}}$  over a group  $G * K_{k_{i+1}}$ , which, in the case when  $G$  is free, is just a free group  $F_{k_{i+1}}$ . Every solution of  $S_{k_{i+1}}$  gives a solution of the system (1).

**Definition 13.** For a given system of equational triangles in  $H$ , the union of all non-free equational triangles, in all ranks from 0 to  $k_{i+1}$  will be called a *tower of non-free equational triangles generated by this system*. The same non-free equational triangle can occur in different ranks; in this case we consider all these occurrences as one triangle of the tower.

**Lemma 6.** *If a solution of a system of triangular equations is minimal, then in the tower of non-free equational triangles generated by this system there is at least one nontriangular middle for the non-free triangles in each rank.*

*Proof.* Suppose that in rank  $j$  all the middles are triangular. Let  $\beta(X_1), \dots, \beta(X_L)$  be the canonical representatives of the elements of the solution. Then they are part of a solution of the system  $S_{k_{i+1}}$ . The constant  $t_i$  does not participate in the equations of the system  $S_{k_{i+1}}$ . Then we can cut out  $\langle t_j \rangle$ -syllables from all the elements in the solution of  $S_{k_{i+1}}$  and again have a solution of  $S_{k_{i+1}}$ . Every solution of  $S_{k_{i+1}}$  produces a solution of the system (1). This contradicts the minimality of the original solution.

**Lemma 7.** *Every middle in rank  $k_i + p$  can be split into several free equational triangles and at most one non-free equational triangle in the previous rank.*

*Proof.* Every triangular middle will be itself a triangular equation in the previous rank.

Consider the equational triangle in Fig. 7(a). Let  $ABCDEF$  be the middle of this triangle. Suppose the pseudoangle  $AB$  is nontrivial and  $AB$  is a positive power

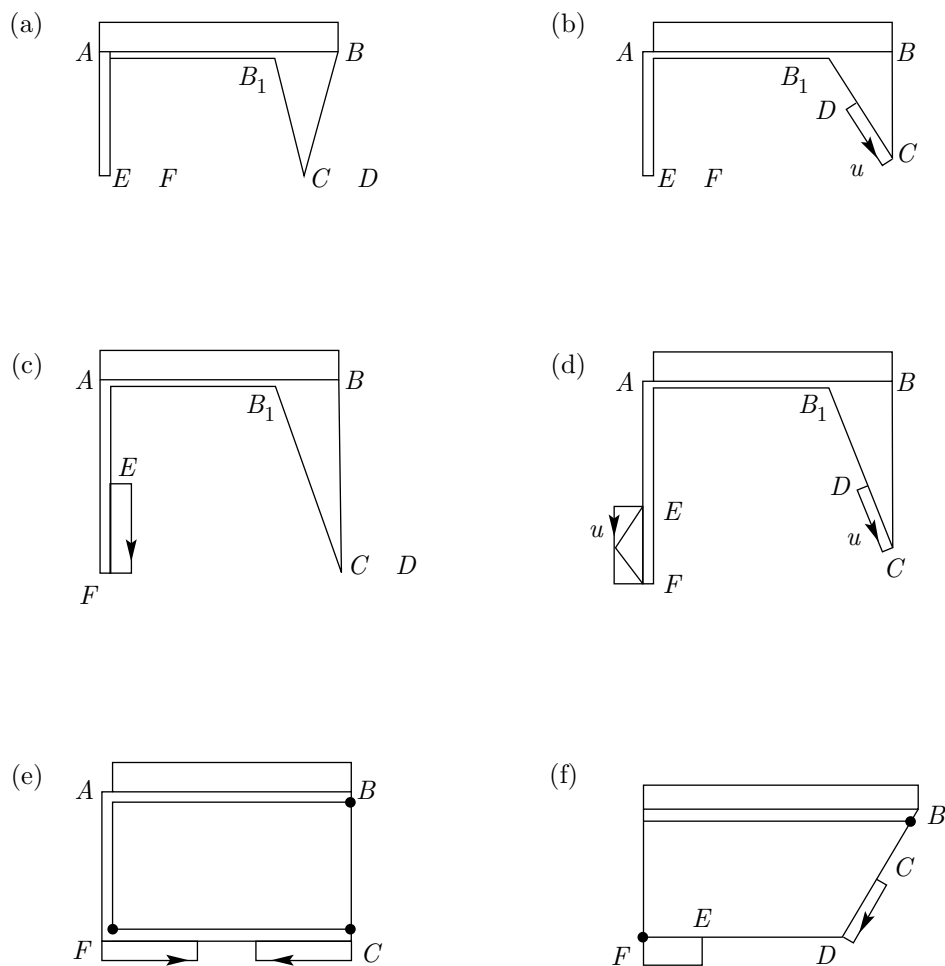

FIGURE 11

of  $u$ . Let  $B_1$  be the left end of the zone for  $\phi(CB)$ , and  $B_2$  be the left end of the zone for  $\phi(DB)$ . Consider the following possibilities. They all are shown in Fig. 11 with the corresponding letter; in the cases (a)–(d) the pseudoangle  $AB$  is long. Non-free equational triangles are marked by a star. All the assertions below follow directly from Lemma 4.

(a) Two other pseudoangles are trivial. We have  $E = F, C = D$ . Then there is a free equational diagram, with the boundary  $\phi(FA)\phi(AB_1)\beta\phi(B_1C)\phi(CF)$ , and an equational triangle with the boundary  $\phi(CB)\phi(BB_1)\beta\phi(B_1C)$ .

(b) The pseudoangle  $EF$  is trivial,  $\phi(CD)$  is a negative power of  $u$ . There is one non-free equational triangle, with the boundary  $\phi(CB)\phi(BB_1)\beta\phi(B_1C)$ , and two free equational diagrams, with the boundaries  $\phi(CD)\phi(DF)\phi(FD)$  and  $\phi(FA)\phi(AB_1)\beta\phi(B_1C)$ .

(c) The pseudoangle  $CD$  is trivial,  $\phi(FE)$  is a negative power of  $u$ . There is one non-free equational triangle, with the boundary  $\phi(CB)\phi(BB_1)\beta\phi(B_1C)$ ,

and two free equational diagrams with the boundaries,  $\phi(CE)\phi(EF)\phi(FC)$  and  $\phi(FA)\phi(AB_1)\beta\phi(B_1C)$ .

(d) The pseudoangles  $CD$  and  $FE$  are both nontrivial,  $CD$  and  $FE$  are negative powers of  $u$ . There is one non-free equational triangle, with the boundary  $\phi(CB)\phi(BB_1)\beta\phi(B_1C)$ , and two free equational diagrams, with the boundaries  $\phi(CD)\phi(DE)\phi(EF)\phi(FC)$  and  $\phi(FA)\phi(AB_1)\beta\phi(B_1C)$ .

In the case where there are no long pseudoangles, the middle is short, and, up to the relabelling of the vertices, there are two different possibilities:

(e)  $EF$  and  $DC$  are positive powers of  $u$ . There is one non-free equational triangle, with the boundary  $\phi(CB)\beta\phi(BF)\beta\phi(FC)$ , and two free equational diagrams, with the boundaries  $\phi(EF)\phi(FC)\phi(CD)\phi(DE)$  and  $\beta\phi(FB)\phi(BA)\phi(AF)$ .

(f)  $EF$  and  $CD$  are positive powers of  $u$ . There is one non-free equational triangle, with the boundary  $\beta\phi(FB)\beta\phi(BD)\beta\phi(DF)$ , and three free equational diagrams, with the boundaries  $\phi(CD)\beta\phi(DB)\phi(BC)$ ,  $\phi(EF)\beta\phi(FD)\phi(DE)$  and  $\phi(FA)\phi(AB)\beta\phi(BF)$ .

The lemma is proved.

**Lemma 8.** *Consider  $n$  non-free equational triangles in rank  $k_i + p$ . Suppose the solution is minimal. Then we can rewrite the system as a system of free equational triangles and at most  $n$  non-free equational triangles in ranks less than  $k_i + p$ . The variables in the new non-free equational triangles are of the following types: the connectors in the middles in rank  $k_i + p$ , and variables  $\bar{Z}_q$  such that there is a free equation, either of the form  $\bar{Z}_q = u^q_{k_i+p}$  or of the form  $\bar{Z}_q = u^{q_1} T u^{q_2}$ , where  $T$  is the label of some connector.*

*Proof.* Every nontriangular middle can be split by the previous lemma into several free equational triangles and at most one non-free equational triangle. The form of the new variables is obtained in the proof of the previous lemma.

**Lemma 9.** *In the minimal solution, the difference  $k_{j+1} - j$ , and hence the number of  $u$ 's containing some fixed  $t_j$  as the greatest root (which is equal to the difference  $k_{j+1} - k_j$ ), cannot be more than  $3M$ , where  $M$  is the number of equations in the original system.*

*Proof.* We will show that, when we consider non-free equational triangles in ranks  $k_{j+1}, k_{j+1} - 1, \dots$ , we have to come to rank  $j$  after not more than  $3M$  steps. Indeed, consider one non-free equational triangle in rank  $k_{j+1}$ . In Fig. 12 we show three paired  $t_p$ -strips, for  $p > i$ , closest to the center of this triangle. Let them be  $t_{p_1}, t_{p_2}$  and  $t_{p_3}$ -strips. Then this triangle will produce non-free triangular equations with

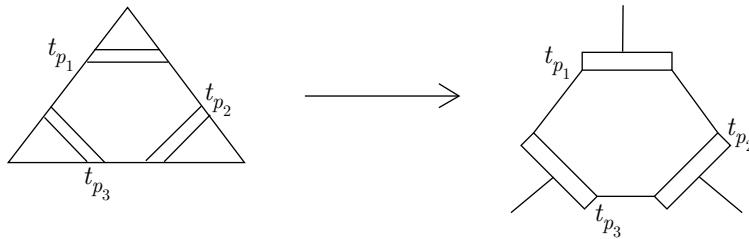

FIGURE 12

nontriangular middles in at most three ranks from  $k_{j+1}$  to  $j + 1$ . These ranks can be only  $p_1, p_2$  and  $p_3$ . In each rank we have at least one equational triangle with non-triangular middle. Hence the maximal possible number of ranks between  $k_{j+1}$  and  $j + 1$  is  $3M$ . The lemma is proved.

After considering some level  $j$ , we have an effectively bounded number of free equations of the second type connecting the variables  $Z_1, \dots, Z_m$ , formed on this level, and powers of  $u_k$ 's, where  $k \in \{k_j, \dots, k_{j+1} - 1\}$ . These equations have one of the following forms:  $Z_{j_1} = Z_{j_2} u_k^q Z_{j_3}$  or  $Z_j = u_k^l, Z_j = u_k^l Z_s u_k^r$ , where  $l, r \in \{1, 2, 3, 4\}$ .

## 7. SHORTENING OF MIDDLE-STRIPS

We now want to bound the powers of  $u_j$ 's in the free equational diagrams. Here  $j \geq k_1$ , in the case when  $G$  is not a free group, and  $j \geq 1$  in the case when  $G$  is a free group.

We denote  $u = u_{k_{i+1}}, t = t_{k_{i+1}}$ .

**Definition 14.** A *middle- $t$ -strip* is a  $t$ -strip formed by  $t$ -cells such that their  $u$ -sides belong to the long pseudoangle of the middle of some non-free equational triangle in rank  $k_{i+1}$ .

Notice that if two paths contain  $t_i$ , and represent the same element in  $H_i$ , then their canonical representatives are chosen in such a way that the part between the first and the last  $\langle t_i \rangle$ -syllable is the same word in  $F_{k_{i+1}}$ . So we can talk about the subword  $u$  in  $H_i$ . (Recall that we write  $u$  instead of  $\beta(u)$ .)

**Definition 15.** A subword  $u^k$  of the label of a side of an equational triangle is called *shrinkable* if one of the following conditions is satisfied:

1. There is an occurrence of  $u$  in  $u^k$  which is on the boundary of some  $t$ -cell belonging to some middle- $t$ -strip.
2.  $u^k$  is a subword of some shrinkable subword  $u^l$  of a side of an equational triangle.
3. Suppose there is a common subpath of two sides of an equational triangle labelled by  $\beta(X)$  and  $\beta(Y)$ . Suppose that the label of this common subpath is a shrinkable subword of  $\beta(X)$ . Then it is also a shrinkable subword of  $\beta(Y)$ .

So, to be precise, the set of all shrinkable subwords of labels  $\beta(X)$  of sides of equational triangles is the smallest class of subwords satisfying the above description.

A similar definition can be given for shrinkable subwords  $t^k$ .

Suppose we have an equational triangle with the boundary label  $XYZ$ . Suppose this triangle contains a middle- $t$ -strip. Then some maximal shrinkable subword  $u^k$  of some variable, say  $X$ , contains a part of the boundary of this middle- $t$ -strip. There are two possibilities. Either some maximal shrinkable subwords  $t^{k_{i+1}n_1}$  of  $Y$  and  $t^{k_{i+1}n_2}$  of  $Z$  both contain a part of the boundary of this middle- $t$ -strip (Fig. 13(a)) or the maximal shrinkable subword  $t^{k_{i+1}n_1}$  of  $Y$  contains the  $t$ -side of the boundary of this middle- $t$ -strip, and the maximal shrinkable subword  $t^{k_{i+1}n_2}$  of  $Z$  is the label of a common path of  $Y$  and  $Z$  (going along the other part of the subword  $t^{k_{i+1}n_1}$  of  $Y$ ) (Fig. 13(b)).

Suppose the triangle  $XYZ$  does not contain a middle- $t$ -strip. It might happen that one part of some maximal shrinkable subword  $u^k$  (resp.  $t^{k_{i+1}n_1}$ ) of  $X$  labels some common path of  $X$  and  $Y$  and another part labels some common path of  $X$

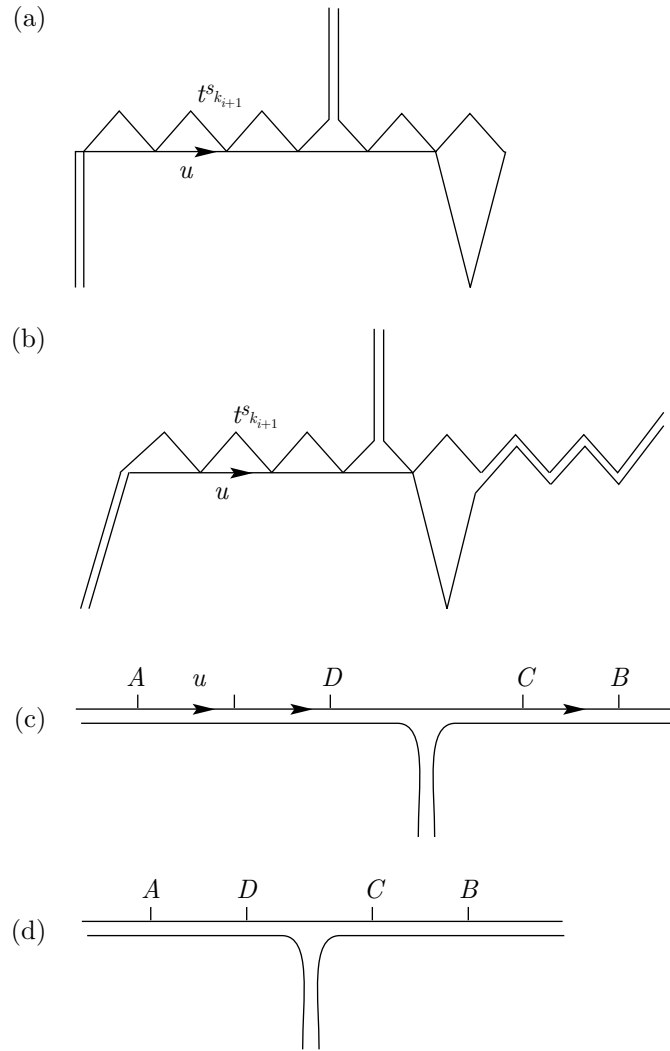

FIGURE 13

and  $Z$  (see Fig. 13(c), 13(d)). In both cases a maximal shrinkable piece of the triangle is the minimal subdiagram having these three maximal shrinkable subwords on its boundary. (In the cases shown in Fig. 13(c), 13(d), these pieces  $ABCD$  and  $ABC$  do not contain any cells.)

Denote the set of maximal shrinkable pieces by  $\mathcal{S}$ . The following lemma is obvious.

**Lemma 10.** *Every maximal shrinkable piece has one of the forms shown in Fig. 14 (broken line for  $t$ , bold line for  $u$ ).*

Below, we will consider only shrinkable subwords  $u^k$ ,  $k \geq 4$ , and  $t^l$ ,  $l > 4s_{k_{i+1}}$ .

**Definition 16.** The length of the shrinkable subword  $u^k$  is  $k - 4$ , and the length of the shrinkable subword  $t^{s_{k_{i+1}}j+r}$ , where  $0 < r < s_{k_{i+1}}$ , is  $j - 4$ .

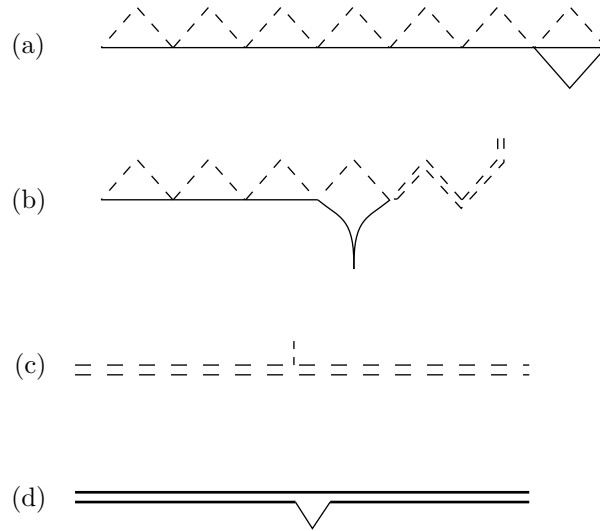

FIGURE 14

Every maximal shrinkable piece contains three maximal shrinkable subwords. Denote them by  $a_{kj}$ ,  $j = 1, 2, 3$ , and their lengths by  $\ell_{i1}, \ell_{i2}, \ell_{i3}$ . For example,  $a_{k3} = u^{4+\ell_{k3}}, a_{k1} = t^{s_{k_{i+1}}(4+\ell_{k1})}, a_{k2} = t^{s_{k_{i+1}}(4+\ell_{k2})}$ . Each diagram in  $\mathcal{S}$  gives one of the equations  $\ell_{i1} + \ell_{i2} + s = \ell_{i3}$ , where  $s \in \{1, 2, 3, 4, 5\}$ . Denote this system of equations, assigned to  $\mathcal{S}$ , by  $\mathcal{L}$ . Add to this system (with less than  $3M$  unknowns) the equalities and inequalities  $\ell_{ij} = \ell_{ip}, \ell_{ij} > 0, \ell_{ij} = 0$ , and the equations that keep the length of the short pseudoangles and maximal shrinkable subwords of nonpositive length.

It is possible to obtain only a finite number (depending on  $M$ ) of distinct linear systems of this form. Every such system is algorithmically solvable. This follows from the fundamental result of Presburger [10] about the decidability of the elementary theory of the natural numbers with addition. Take one solution for each system. Let  $\bar{L}$  be the maximum of the  $\ell_{ij}$  in these solutions. Then the system  $\mathcal{L}$  also has a solution bounded by  $\bar{L}$ . Let

$$\{\bar{\ell}_{kj}, i = 1, \dots, M, j = 1, 2, 3\}$$

be this solution,  $b_{kj}$  the pieces corresponding to  $a_{kj}$ , but of length  $\bar{\ell}_{kj}$  (for example, if  $a_{k3} = u^{4+\ell_{k3}}$ , then  $b_{k3} = u^{4+\bar{\ell}_{k3}}$ .)

**Lemma 11.** *Replace all the pieces  $a_{ij}$  by the analogous pieces  $b_{ij}$ . We get another solution of the original system of equations.*

Suppose we replaced all  $a_{ij}$  by the corresponding  $b_{ij}$ . If some  $a_{ij}$  participated in several maximal shrinkable pieces, then  $\ell_{ij}$ , and hence  $\bar{\ell}_{ij}$ , satisfy linear equations for all these pieces. In the places which do not meet shrinkable pieces, replacing  $a_{ij}$  by  $b_{ij}$  also does not destroy the solution. The lemma is proved.

We have described how to obtain another solution with the length of middle strips in rank  $k_{i+1}$  bounded by  $\bar{L} + 4$ . We now use induction. Suppose that the middle strips are bounded for all  $u_{k_{i+1}-1} \dots u_{k_{i+1}-j+1}$ , and bound them for  $u_{k_{i+1}-j}$ . We add new variables and rewrite free equational diagrams of the second type as

equational triangles. We will obtain a bounded number of equational triangles, because the length of the middle strips for  $u_{k_{i+1}-1} \dots u_{k_{i+1}-j+1}$  is bounded and the number of equational triangles obtained from free equational diagrams depends on the lengths of the middle strips.

We got some shrinkable pieces in rank  $k_{i+1} - j$ ; we name then  $a_{rl}$ ,  $l = 1, 2, 3$ . If  $a_{rl}$  coincides with a piece of another solution not in the middle, we also name this piece  $a_{rl}$ . The word  $a_{rl} = u_{k_{i+1}-j}^m$  can be a subword of some greater word  $u_{k_{i+1}-p}$  and touch it somewhere, but since we consider all free and non-free equational triangles, this is taken into consideration in the equations. The replacement of  $a_{rl}$  in  $u_{k_{i+1}-p}$  by  $b_{rl}$  can turn  $u_{k_{i+1}-p}$  into a proper power (in which case we turn the corresponding  $t_{k_{i+1}-p}$  into the same power), but it cannot turn  $u_{k_{i+1}-p}$  and  $u_{k_{i+1}-p_1}$  into proper powers of the same word, because the number of roots was taken to be minimal.

Indeed, if we obtained  $u = v^s, u = t_1^\alpha, v = t_2^\gamma$ , we could put  $t_1 = t_3^{s\gamma}, t_2 = t_3^\alpha$ , and this would be another solution with fewer roots added.

Now suppose by induction that we have bounded the lengths of the middle-strips at all levels higher than  $j$ . Free equational triangles at levels higher than  $j$  do not affect the maximal shrinkable pieces at level  $j$ . Indeed, free equations on levels higher than  $j$  just equate some of the  $\langle t_r \rangle$ -syllables, for  $r > k_{j+1}$ , and some of the  $(u_k, u_l)$ -connectors between two neighboring  $\langle t_k \rangle, \langle t_l \rangle$ -syllables, where  $k, l > j$  are equal. All the maximal shrinkable subwords  $u_j^k$  at level  $j$  are inside these connectors. All the maximal shrinkable subwords  $t_r^k$ , where  $r \in \{k_j + 1, \dots, k_{j+1}\}$ , coincide with some of these  $\langle t_r \rangle$ -syllables. For the level  $j$  we just repeat the procedure described for the level  $i$ . Because there are only a bounded number of  $u$ 's on the same level, and the number of non-free equations does not exceed  $M$ , we can get a boundary for the lengths of middles at each level. So all middle  $t$ -strips, at all the levels greater than 0, can be shortened.

If  $G$  is a free group, the middle  $t$ -strips at level 0 can be shortened by the same procedure.

**Lemma 12.** *Starting with a minimal solution, with bounded lengths of middle  $t_k$ -strips at all levels, it is possible to construct a solution with bounded depth in every rank  $j$  of the root  $t_j$  (i.e. the  $s_j$ 's are bounded).*

*Proof.* Suppose, by induction, that we have bounded the depth of the roots on all levels higher than  $j$ , and in the ranks  $k_{j+1}, \dots, k_{j+1} - p + 1$ . Now we will bound it in rank  $k_{j+1} - p$ . Consider all non-free equational triangles in rank  $k_{j+1} - p$ , together with all their middle strips as shown in Fig. 14(a), 14(b), 14(c). Let  $a_{ik} = t_{k_{j+i}-p}^{4+l_{ik}}$  be a shrinkable  $t_{k_{j+i}-p}$ -subword. For the middle strips we can write the system of linear equations with variables  $l_{ik}$  and  $d$ , where  $d$  is the depth of the root  $t_{k_{j+1}-p}$ .

We have no more than  $M$  equations of the form  $t_{k_{j+1}-p}^{x_1} t_{k_{j+1}-p}^{x_2} = u_{k_{j+1}-p}^s$  ( $s$  is bounded by the maximal length of middle-strips) or  $t_{k_{j+i}-p}^{x_1} t_{k_{j+i}-p}^{x_2} = t_{k_{j+i}-p}^{x_3}$ . So we have a homogeneous system of linear equations with not more than  $3M$  variables. These equations can only be of the form  $x_i \pm x_j = sd$  ( $s$  is bounded, by  $\bar{L}$ ), or  $x_i + x_j = x_k$ . The prime divisors of  $d$  must belong to the set  $\pi$ ,  $x_i \geq 0$ . The minimality of the solution  $X = \{X_1, \dots, X_L\}$  implies that the linear system does not admit solutions in which one of the  $x$ 's is divisible by  $d$ . This implies that, after transforming the system to reduced row-echelon form, we can only have  $d$  as a free variable, and can either solve the system or see that it is unsolvable.



There can be only a finite number of such systems, with each system having some solution; if  $\tilde{L}$  is the greatest value of  $d$  in all these solutions, then we always can find a solution of system (1) where the depth of the roots is bounded by  $\tilde{L}$ . The lemma is proved.

## 8. THE PROOF OF THEOREM 1

From now on we suppose that the group  $G$  is free. So  $F = G$ , and on level zero we have only free equations.

**Proposition 1.** *It is possible to determine a recursive function  $\psi(M)$  such that if a system of  $M$  triangular equations has a solution in  $F^{\mathbf{Q}}$ , then it also has a solution in some group  $H_{\psi(n)}$ , where  $H_0 = F$  and  $H_{i+1}$  is obtained from  $H_i$  by adding some root.*

*Proof.* It is possible to find a number  $\psi(M)$  such that if  $k_{i+1}$  is greater than  $\psi(M)$ , there will be some numbers  $r$  and  $s < r$  such that  $k_{r+1} - r = k_{s+1} - s$  and the following conditions are satisfied:

1. The systems of non-free equations in ranks  $r$  and  $s$  are equivalent (there exists a bijection between their sets of variables that induces a bijection between their solution sets).
2. Let  $Y_1, \dots, Y_p, u_{r+1}, \dots, u_{k_{r+1}}$  be the variables in the system of non-free equations in rank  $r$  and  $Z_1, \dots, Z_p, u_{s+1}, \dots, u_{k_{s+1}}$  the variables in the system of non-free equations in rank  $s$ . As variables,  $u_{r+1}, \dots, u_{k_{r+1}}$  correspond to  $u_{s+1}, \dots, u_{k_{s+1}}$ .
3. The corresponding roots of  $u_{r+1}, \dots, u_{k_{r+1}}$  and of  $u_{s+1}, \dots, u_{k_{s+1}}$  have the same depth.
4. Consider first free equations of the second type in ranks from  $r+1$  to  $k_{r+1}$ . They imply certain free equations for  $(u_j, u_k)$ - and  $u_j$ -connectors in  $H_r$  (those which are defined) and original variables in  $H_r$ ,  $j, k \in \{r+1, \dots, k_{r+1}\}$ . Hence the variables  $Y_1, \dots, Y_p, u_{r+1}, \dots, u_{k_{r+1}}$  satisfy some free equations. Next, consider the free equations of the second type in ranks from  $s+1$  to  $k_{s+1}$ . They likewise imply certain free equations for  $(u_j, u_k)$ - and  $u_j$ -connectors and original variables in  $H_s$ ,  $j, k \in \{s+1, \dots, k_{s+1}\}$ . Hence the variables  $Z_1, \dots, Z_p, u_{s+1}, \dots, u_{k_{s+1}}$  also satisfy some free equations. The systems of the free equations for the variables  $Y_1, \dots, Y_p, u_{r+1}, \dots, u_{k_{r+1}}$  and for the variables  $Z_1, \dots, Z_p, u_{s+1}, \dots, u_{k_{s+1}}$  must be equivalent.

Indeed, the number of roots on a given level, as well as the difference  $k_{j+1} - j$ , are bounded by Lemma 9, the length of middlestrips is bounded, the number of free equations of the second type at every level is bounded, and the depth of the roots is bounded by Lemma 12.

We now replace all the variables in equational triangles in rank  $r$  by the corresponding variables in equational triangles in rank  $s$ . In particular  $u_{r+1}, \dots, u_{k_{r+1}}$  will be replaced by  $u_{s+1}, \dots, u_{k_{s+1}}$ ;  $(u_k, u_l)$ - and  $u_k$ -connectors, for  $k, l \in \{r+1, \dots, k_{r+1}\}$  participating in non-free equational triangles, will be replaced by the corresponding  $(u_k, u_l)$ - and  $u_k$ -connectors, for  $k, l \in \{s+1, \dots, k_{s+1}\}$ . If some  $(u_k, u_l)$ - or  $u_k$ -connector, for  $k, l \in \{r+1, \dots, k_{r+1}\}$ , or original variable in  $H_r$  does not participate in nonfree equations, then we can replace it by an arbitrary element in  $H_s$ .

Our purpose is to show that we will again obtain a solution. Indeed, consider first what will happen to the free equational triangles that come from the levels higher than  $r$ . These equations just indicate that some of the  $(u_k, u_j)$ - and  $u_j$ -connectors are the same and some of the  $\langle t_j \rangle$ -syllables are the same, for  $j, k \in \{r+1, \dots, k_{r+1}\}$ . We will have to replace the pieces corresponding to  $u_{r+1}, \dots, u_{k_{r+1}}$  in these equations by the pieces corresponding to  $u_{s+1}, \dots, u_{k_{s+1}}$ , and hence to change  $u_{k_{r+1}+1}$  and all the highest  $u$ 's. But all these pieces are between two neighboring occurrences of  $t_j$  and  $t_k$ ,  $j, k \in \{r+1, \dots, k_{i+1}\}$ , so do not affect the other structure of free equations. We also will replace the pieces corresponding to  $(u_j, u_k)$ -connectors in  $H_r$ , for  $j, k \in \{r+1, \dots, k_{r+1}\}$ , by the pieces corresponding to  $(u_j, u_k)$ -connectors in  $H_s$ , for  $j, k \in \{s+1, \dots, k_{s+1}\}$ , and again this will change some connectors; however, all the connectors which were the same will remain the same.

So we obtain a solution with fewer roots (we do not need  $t_{s+1}, \dots, t_{k_{s+1}}$  if  $k_{s+1} < r+1$ , or  $t_{s+1}, \dots, t_{r+1-1}$  if  $k_{s+1} \geq r+1$ ). Indeed, now  $t_{r+1}, \dots, t_{k_{r+1}}$  will be the roots of  $u_{s+1}, \dots, u_{k_{s+1}}$ . We have obtained a contradiction with the minimality of our solution.

The proposition is proved.

It follows from the proposition that  $k_{i+1} = \psi(M)$ . The length of the middle  $t_j$ -strips, in all the ranks  $j$ , is bounded. We will construct a system of equational triangles in  $F_{k_{i+1}}$ , as it was described in Section 6. The number of possible systems of free equations that correspond to these systems of equational triangles is bounded, and we can list them. Finally we have a finite number of possible systems of equations in the free group  $F_{k_{i+1}}$ , with the restriction that some of the variables belong to subgroups generated by only a part of the generating set of the free group  $F_{k_{i+1}}$ . Each such system is algorithmically decidable [7]. If all these systems are incompatible, then our system does not have a solution. If at least one of them is consistent, we obtain a solution of our system by substituting the corresponding  $P_i$ 's  $u_j$ 's and  $T_k$ 's in the expressions for unknowns.

## 9. THE PROOF OF THEOREM 2

To prove Theorem 2 we first need some definitions.

A subgroup  $G$  is called *existentially closed* in a group  $H$  if any existential sentence, with constants from  $G$ , holds in the whole group  $H$  if and only if it holds in the subgroup  $G$ .

Let  $G$  be a subgroup of  $H$ . A finite system of equations  $W(x, g) = \{w_1(x, g) = 1, \dots, w_k(x, g) = 1\}$ , with variables  $x = (x_1, \dots, x_n)$  and constants  $g = (g_1, \dots, g_m)$  from  $G$ , has a solution in  $H$  (resp. in  $G$ ) if and only if the following formula holds in  $H$  (resp. in  $G$ ):

$$\exists x(w_1(x, g) = 1 \wedge \dots \wedge w_k(x, g) = 1).$$

Therefore, if  $G$  is existentially closed in  $H$ , then any system  $W(x, g) = 1$ , with constants in  $G$ , has a solution in  $H$  if and only if it has a solution in  $G$ .

Let  $G$  be a subgroup of  $H$ . Following [3] we will say that  $H$  is *locally  $\omega$ -separated in  $G$  by retractions* if for finitely many arbitrary nontrivial elements  $h_1, \dots, h_n \in H$  there exists a homomorphism  $\psi : H \rightarrow G$ , which is the identity on  $G$ , such that the images of  $h_1, \dots, h_n$  under  $\psi$  are also nontrivial in  $G$ .

In [3] the following result has been proven: Let  $G$  be a torsion-free hyperbolic group and  $A$  a ring of characteristic 0. Then  $G^A$  is locally  $\omega$ -separated in  $G^{\mathbf{Q}\pi(A)}$  by retractions.

**Lemma 13.** *Let  $G$  be a subgroup of  $H$ . If  $H$  is locally  $\omega$ -separated in  $G$  by retractions, then  $G$  is existentially closed in  $H$ .*

*Proof.* From general predicate calculus we know that any existential sentence in the group theory language with constants from  $G$  is equivalent to a sentence of the following type:

$$\Phi = \exists x \left( \bigwedge_1^s u_i(x, g) = 1 \bigwedge_1^t v_j(x, g) \neq 1 \right),$$

where the  $u_i$ 's and  $v_j$ 's are group words,  $x = (x_1, \dots, x_n)$  are variables and  $g = (g_1, \dots, g_k)$  are some constants from  $G$ .

Let the elements  $h = (h_1, \dots, h_n) \in H$  satisfy the quantifier-free part of this sentence in  $H$ . Denote by  $H_0$  the subgroup  $\langle h_1, \dots, h_n \rangle$  in  $H$ . By the conditions of the lemma there exists a homomorphism  $f : H_0 \rightarrow G$  which separates the elements  $v_1(h_1, \dots, h_n), \dots, v_t(h_1, \dots, h_n)$  in  $G$ . This implies that the images  $f(h_1), \dots, f(h_n)$  satisfy in  $G$  the same equalities  $u_i(f(h_1), \dots, f(h_n)) = 1, i = 1, \dots, s$ , and inequalities  $v_i(f(h_1), \dots, f(h_n)) \neq 1, i = 1, \dots, t$ . Therefore, the sentence  $\Phi$  holds in  $G$ . This shows that  $G$  is existentially-closed in  $H$ .  $\square$

**Corollary 3.** *Let  $G$  be a torsion-free hyperbolic group and  $A$  a ring of characteristic 0. Then  $G^{\mathbf{Q}\pi(A)}$  is existentially closed in  $G^A$ .*

Now we can complete the proof of Theorem 2. By the corollary above,  $F^{\mathbf{Q}\pi(A)}$  is existentially closed in  $F^A$ ; hence any system  $W = 1$  with coefficients from  $F$  has a solution in  $F^A$  if and only if it has a solution in  $F^{\mathbf{Q}\pi(A)}$ . The result now follows from Theorem 1.

## 10. EQUATIONS AND INEQUALITIES IN $F^{\mathbf{Q}\pi}$

In this section we show how to prove the algorithmic decidability of the universal theory of the group  $F^{\mathbf{Q}\pi}$  (with constants from  $F^{\mathbf{Q}\pi}$ ) to a question in the free group  $F$ .

To prove the decidability of the universal theory of  $F^{\mathbf{Q}\pi}$  one has to construct an algorithm solving finite systems of equations and inequalities in  $F^{\mathbf{Q}\pi}$ . Such a system can be reduced to the system of triangular equations (1) together with some inequalities  $X_k \neq 1$ . The algorithm constructed in this paper can be used to reduce the system to a finite number of possible systems of equations and inequalities in the free group  $F_{k_{i+1}}$ , with the restriction that some of the variables belong to subgroups generated by only a part of the generating set of the free group  $F_{k_{i+1}}$ .

This problem can be solved by methods described in [7].

## REFERENCES

1. G Baumslag, *On free  $\mathcal{D}$ -group*, Comm. Pure and Appl. Math., **18** (1965) 25–30. MR **31**:1293
2. ———, *Some aspects of groups with unique roots*, Acta Math., **104** (1960), 217–303. MR **23**:A191
3. G. Baumslag, A. Myasnikov, and V. Remeslennikov, *Residually hyperbolic groups*, preprint, 1996.

4. L. P. Comerford Jr., and C. C. Edmunds, *Solutions of equations in free groups*, Group Theory (Singapore, 1987; K. N. Cheng and Y. K. Leong, editors), de Gruyter, Berlin, 1989, pp. 347–356. MR **90a**: 20067
5. R. I. Grigorchuk and P. F. Kurchanov, *On quadratic equations in free groups*, Proc. Internat. Conf. Algebra (Novosibirsk, 1989), Part 1, Contemp. Math., vol. 131, Amer. Math. Soc., Providence, RI 1992, pp. 159–171. MR **94m**:20074
6. O. Kharlampovich and A. G. Myasnikov, *Hyperbolic groups and free constructions*, Trans. Amer. Math. Soc. **350** (1998), 571–613.
7. G.S. Makanin, *Decidability of the universal and positive theories of a free group*, Izv. Akad. Nauk SSSR, Ser. Mat. **48** (1984), 735–749; English transl., Math. USSR Izv. **25**, (1985), 75–88. MR **86c**:03009.
8. ———, *Equations in a free group*, Izv. Akad. Nauk SSSR, Ser. Mat. **46** (1982), 1199–1273; English transl., Math. USSR Izv. **21** (1983), 483–546. MR **84m**:20040
9. A. G. Myasnikov and V. N. Remeslennikov. *Exponential groups II: Extension of centralizers and tensor completion of CSA-groups*, Internat. J. Algebra Comput. **6** (1996), 687–712.
10. H. Presburger, *Über die Vollständigkeit eines gewissen Systems der Arithmetik ganzen Zahlen*, C. R. 1 Congr. Math. Pays Slaves, Warsaw, 1929, pp. 92–101.
11. A. A. Razborov, *On systems of equations in a free group*, Izv. Akad. Nauk SSSR Ser. Mat. **48** (1984), 779–832; English transl., Math. USSR Izv. **25** (1985), 115–162. MR **86c**:20033
12. E. Rips and Z. Sela, *Canonical representatives and equations in hyperbolic groups*, Invent. Math. **120** (1995), 489–512. MR **96c**:20053

DEPARTMENT OF MATHEMATICS AND STATISTICS, MCGILL UNIVERSITY, MONTRÉAL, P.Q., CANADA H3A 2K6

*E-mail address:* `olga@triples.math.mcgill.ca`

DEPARTMENT OF MATHEMATICS, CITY COLLEGE (CUNY), CONVENT AVENUE AND 138TH STREET, NEW YORK, NEW YORK 10031-9100

*E-mail address:* `alexei@rio.sci.cuny.edu`