

TRANSVERSE SURFACES AND ATTRACTORS FOR 3-FLOWS

W. J. COLMENAREZ AND C. A. MORALES

ABSTRACT. We prove that a hyperbolic strange attractor of a three-dimensional vector field is a suspension if it exhibits a transverse surface over which the unstable manifold induces a lamination without closed leaves. We also study the topological equivalence of singular attractors exhibiting transverse surfaces for three-dimensional vector fields.

0. INTRODUCTION

In this paper we consider hyperbolic strange attractors with a transverse surface for three-dimensional vector fields. The motivation is the known fact that an Anosov three-dimensional vector field is a suspension if it exhibits a transverse torus over which the unstable manifold induces a foliation without closed leaves [Fe1], [Fe2]. Indeed, we generalize this result for hyperbolic strange attractors exhibiting transverse surfaces.

We are also interested in the topological equivalence of singular attractors exhibiting transverse surfaces for three-dimensional vector fields. Indeed, we show that there is no equivalence between the geometric Lorenz attractors [GW] and the singular attractor described in §5 (see Figure 2(a)). This result is claimed in [MP], but the proof there is only a sketch. Here we fill in the details of the proof in [MP] by using the ideas developed in §2. We hope that similar ideas can be used to study the equivalence between singular attractors with transverse surface in a general setting.

Let us state our results precisely. Let X denote a vector field on a closed manifold M and let X_t denote the flow generated by X . Define $\omega_X(q)$, the ω -limit set of q , as the set of accumulation points of the positive orbit $\{X_t(q) : t \geq 0\}$ of q . A compact invariant set Λ of X is *transitive* if $\Lambda = \omega_X(q)$ for some $q \in \Lambda$; *singular* if it contains a singularity of X ; and *attracting* if it can be realized as $\bigcap_{t \geq 0} X_t(U)$ for some positively invariant open set U (i.e. $X_t(U) \subset U, \forall t > 0$). An *attractor* is a transitive attracting set.

An invariant set Λ is *hyperbolic* if it has an invariant splitting $E^s \oplus E^X \oplus E^u$ so that E^s is contracting, E^u is expanding and E^X is the direction of X ([PS]). If $p \in \Lambda$, there are invariant manifolds $W_X^s(p)$, $W_X^u(p)$, $W_X^{ss}(p)$ and $W_X^{uu}(p)$ which are tangent respectively to $E_p^s \oplus E_p^X$, $E_p^X \oplus E_p^u$, E_p^s and E_p^u ([HPS]). The manifold

Received by the editors October 27, 1999 and, in revised form, November 15, 2000.
2000 *Mathematics Subject Classification*. Primary 37Dxx; Secondary 37C15.
Key words and phrases. Anosov flow, hyperbolicity, cross-section.
Partially supported by FAPERJ, CNPq and PRONEX of Brasil.

$W_X^{ss}(p)$ ($W_X^{uu}(p)$) is called a strong stable (unstable) manifold of p . It follows that

$$W_X^{ss}(p) = \{x \in M : d(X_t(x), X_t(p)) \rightarrow 0, t \rightarrow \infty\}$$

and

$$W_X^{uu}(p) = \{x \in M : d(X_t(x), X_t(p)) \rightarrow 0, t \rightarrow -\infty\}.$$

In addition,

$$W_X^s(p) = \bigcup_{t \in \mathbb{R}} W_X^{ss}(X_t(p))$$

and

$$W_X^u(p) = \bigcup_{t \in \mathbb{R}} W_X^{uu}(X_t(p)).$$

A periodic orbit (singularity) of X is hyperbolic if it is a hyperbolic set of X . If \mathcal{O} is a hyperbolic periodic orbit of X , we denote $W_X^s(\mathcal{O}) = W_X^s(p)$ for some $p \in \mathcal{O}$. Clearly, this definition does not depend on $p \in \mathcal{O}$. Similarly, $W_X^u(\mathcal{O}) = W_X^u(p)$. A periodic orbit is attracting (repelling) if it is hyperbolic and $E^u = 0$ ($E^s = 0$). Similarly, for singularities. We say that the point $p \in M$ is *periodic* if its full orbit $\{X_t(p) : t \in \mathbb{R}\}$ is a periodic orbit of X . In that case p is hyperbolic if its corresponding periodic orbit is hyperbolic. The vector field X is *Anosov* if M is a hyperbolic set of X .

By a *surface* we mean a connected embedded 2-manifold with or without boundary. A surface S is *transverse* to Λ if (1) $X(q)$ is not tangent to S ($\forall q \in S$) and (2) $\Lambda \cap S$ is nonempty and does not intersect the boundary of S (if any). Following [Bo], we say that Λ is a *suspension* if it exhibits a transverse surface intersecting every orbit of X in Λ . We shall denote by $\dim(E)$ the dimension of a linear space E .

If Λ is a hyperbolic attracting set, $\dim(E^u) = 1$ and S is a transverse surface of Λ , there is a nonsingular lamination $\mathcal{F}_S^u = \{W_X^u(p) \cap S\}_{p \in \Lambda \cap S}$ on $\Lambda \cap S$. This lamination is defined in particular for *hyperbolic strange attractors*, i.e. hyperbolic attractors with $\dim(E^u) = 1$.

Theorem A. *A hyperbolic strange attractor of a three-dimensional vector field is a suspension if it exhibits a transverse surface S such that \mathcal{F}_S^u has no closed leaves.*

Observe that this result follows from [Fe1] if the attractor is M because, in that case, the vector field is Anosov and the transverse surface is incompressible. Theorem A is proved without using the lifting flow to the universal cover; it will be a direct consequence of Theorem B in §4 (see Example 2.1). Our approach will be used in §5 to prove that the singular attractor in Figure 2(a) and the geometric Lorenz attractor in [GW] are not equivalent.

The second author thanks Pedro Duarte for helpful conversation.

1. PRELIMINARIES

To begin, let Λ be a compact invariant set of a three-dimensional vector field X . We say that Λ is *isolated* if it can be realized as $\bigcap_{t \in \mathbb{R}} X_t(U)$ for some open set U . Obviously, attracting sets are isolated and the converse is not true.

We say that Λ is *connected* if it cannot be realized as the disjoint union of two relatively closed nonempty subsets. It is immediate that transitive sets for flows are connected.

If S is a surface transverse to Λ , we define

$$\sigma_S = \{q \in \Lambda : X_t(q) \notin S, \forall t \in \mathbb{R}\} \quad \text{and} \quad l_S = \{q \in \Lambda \cap S : X_t(q) \notin S, \forall t > 0\}.$$

Note that $\omega_X(q) \subset \sigma_S$ for any $q \in l_S$ since the orbits in Λ do not intersect the boundary of S .

Following [Fr], we say that S is a *cross-section* of Λ if $\sigma_S = \emptyset$. Observe that Λ is a suspension if it exhibits a cross-section.

Example 1.0. The Lorenz attractor is an example of a nonhyperbolic singular attractor Λ of a vector field X exhibiting a transverse surface S with $\sigma_S \neq \emptyset$. In this case, σ_S is a saddle singularity and l_S is a cantor set contained in a curve $c \subset W_X^s(\sigma_S) \cap S$. See Figure 2-(b).

Example 1.1. The supporting manifold of the Anosov flow in [BL] is an example of a hyperbolic attractor Λ exhibiting a transverse surface. In this case, S is a torus, σ_S is a saddle periodic orbit and l_S is the disjoint union of two freely homotopic closed curves in S .

Observe that, in the previous examples, Λ is connected and σ_S is not an attracting set. It seems that this is always true, namely σ_S is not an attracting set for surfaces S transverse to connected isolated sets. We shall prove this assertion below in the case where the involved isolated set is hyperbolic and attracting.

Theorem 1.0. *If S is a surface transverse to a hyperbolic connected attracting set, then σ_S is not an attracting set.*

The next example shows that the above theorem fails for surfaces transverse to compact connected invariant sets in general.

Example 1.2. Let X be a three-dimensional vector field as in Figure 1 having a hyperbolic saddle periodic orbit p , a cross-section S of p , an attracting singularity σ and a flowline γ in the unstable manifold of p joining p with σ (here l_S reduces to the point q in Figure 1). Then, $\Lambda = p \cup \sigma \cup \gamma$ is a compact connected invariant (nonisolated) set exhibiting a transverse surface S with $\sigma_S = \sigma$ attracting.

The hyperbolicity of the attracting set is used in the proof of Theorem 1.0 to obtain stable and unstable manifolds. The idea of the proof is as follows. By contradiction, assume that S is a surface transverse to a connected hyperbolic attracting set Λ and that σ_S is an attracting set. Then $\sigma_S \neq \emptyset$, and so, $l_S \neq \emptyset$ (Lemma 1.2). Taking $q \in l_S$, by the Local Structure Product for hyperbolic sets, we shall have a situation which is similar to Figure 1, namely the backward orbit γ of q converges to the periodic point p . In particular, the unstable manifold of p intersects l_S . By Lemma 1.3, since Λ is an attracting set, there would exist a $q^* \in l_S$ and a connected arc J^* in $\Lambda \cap S$ joining q^* to some point in the orbit of p (note that $q = q^*$ in Figure 1). This fact together with Lemma 1.1 would imply that $p \in \sigma_S$, a contradiction (see Corollary 1.4).

Let us present the details. In what follows, Λ denotes an isolated set of a vector field X and S is a surface transverse to Λ .

Lemma 1.1. *The set σ_S is isolated. If σ_S is an attracting set, then l_S is open and closed in $\Lambda \cap S$.*

Proof. The first claim is obvious. To prove the second one, observe that l_S is closed in $\Lambda \cap S$ and $\omega_X(q) \subset \sigma_S$ for every $q \in l_S$. In particular, l_S is open in $\Lambda \cap S$ if σ_S is an attracting set. □

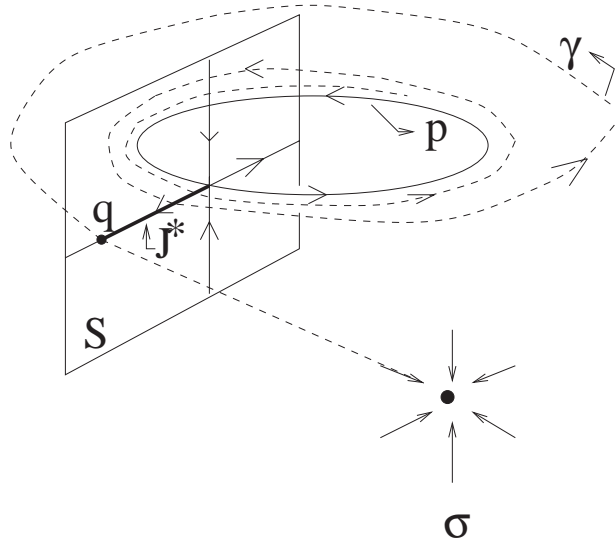

FIGURE 1.

Clearly, $\sigma_S = \emptyset$ implies $l_S = \emptyset$. The converse fails in general as follows: Let Λ be the disjoint union of two compact invariant sets, one of them suspended (with cross-section S). Denote the nonsuspended set by σ . Then, S is a transverse surface of Λ , with $l_S = \emptyset$, and $\sigma_S = \sigma \neq \emptyset$. Note that Λ is not connected in this case.

Lemma 1.2. *If Λ is connected and $l_S = \emptyset$, then $\sigma_S = \emptyset$.*

Proof. By way of contradiction, assume that $\sigma_S \neq \emptyset$. Note that σ_S is closed in Λ by Lemma 1.1.

As $l_S = \emptyset$ by hypothesis, for every $q \in \Lambda \cap S$ there is a first $t_q > 0$ so that $X_{t_q}(q) \in S$. By the Tubular Flow-Box Theorem, as $\Lambda \cap S$ is compact, there is $\beta > 0$ so that $t_q \leq \beta$ for all $q \in \Lambda \cap S$.

Let

$$\Lambda^* = \bigcup_{q \in \Lambda \cap S} \{X_t(q) : t \in [0, t_q]\}.$$

Clearly, $\sigma_S \cap \Lambda^* = \emptyset$. We claim that Λ^* is closed in Λ . Therefore, we choose a sequence $q'_n \in \Lambda^*$ converging to $q \in \Lambda$. Then, by definition, there are sequences $q_n \in \Lambda \cap S$ and $t_n \in [0, t_{q_n}]$ so that $X_{t_n}(q_n) = q'_n \rightarrow q$ as $n \rightarrow \infty$. Note that the sequence t_n is bounded by β since t_{q_n} does. Then, using the compactness of $\Lambda \cap S$ and $[0, \beta]$, we can assume that $q_n \rightarrow q^0 \in \Lambda \cap S$ and $t_n \rightarrow t^0 \in [0, \beta]$. Thus, $X_{t^0}(q^0) = q$ by continuity of X . So $q \in \Lambda^*$ and the claim holds. Now the result follows from the claim since $\Lambda = \Lambda^* \cup \sigma_S$ is connected and both σ_S and Λ^* are closed and disjoint in Λ . □

We denote $\mathcal{O}_X(p) = \{X_t(p) : t \in \mathbb{R}\}$ as the orbit of p . Recall that $p \in M$ is a (hyperbolic) periodic point of X if $\mathcal{O}_X(p)$ is a (hyperbolic) periodic orbit of X .

Lemma 1.3. *Suppose that Λ is an attracting set. If $p \in \Lambda \setminus \sigma_S$ is a hyperbolic periodic point and $W^u_X(p) \cap l_S \neq \emptyset$, then there is $q^* \in l_S$ and a compact connected curve $J^* \subset \Lambda \cap S$ joining q^* to some $p' \in \mathcal{O}_X(p)$.*

Proof. Clearly, $W_X^u(p) \neq \mathcal{O}_X(p)$ and $\mathcal{O}_X(p) \cap S \neq \emptyset$ since $p \notin \sigma_S$. Then, we can choose $p' \in \mathcal{O}_X(p) \cap S$ and a path-connected relatively open set I of $W_X^u(p) \cap S$ containing p' .

Let

$$\Pi : \text{Dom}(\Pi) \subset S \rightarrow S$$

be the return map of X in S . Then, $p' \in \text{Dom}(\Pi)$ is Π -periodic with period T (say). Shrinking I and replacing Π by Π^T if necessary, we can assume that $I \subset \text{Dom}(\Pi)$ and that p' is fixed.

Now, choose $\bar{q}_0 \in W_X^u(p) \cap l_S \neq \emptyset$ by hypothesis. As the α -limit set $\alpha_X(\bar{q}_0) = \omega_{-X}(\bar{q}_0)$ is $\mathcal{O}_X(p)$, there is a sequence $q_k \in W_X^u(p) \cap S$ converging to p' so that $q_0 = \bar{q}_0$, $q_k \in \text{Dom}(\Pi)$ and $\Pi(q_k) = q_{k-1}$ for all $k \geq 1$. In particular, there is n large so that $q_n, q_{n+1} \in I$.

Let F_n be a connected curve in I joining q_n with q_{n+1} . This curve exists since I is path connected. As $F_n \subset I \subset \text{Dom}(\Pi)$, one can define inductively $F_k = \Pi(F_{k+1})$, for $k \in \{0, 1, \dots, n-1\}$, as long as $F_{k+1} \in \text{Dom}(\Pi)$.

Let k^* be the smallest $k \in \{0, 1, \dots, n-1\}$ so that $F_k \subset \text{Dom}(\Pi)$ and

$$J = F_n \cup F_{n-1} \cup \dots \cup F_{k^*+1} \cup F_{k^*}.$$

Observe that $J \subset \Lambda \cap S$ by the flow invariance of $W_X^u(p)$ and the definition of Π (recall that Λ is an attracting set). Moreover, J is a connected curve joining q_{k^*} to q_{n+1} since $\Pi(q_k) = q_{k-1}$ for all k .

Using the pathwise connectedness of I and the fact that $p' \in I$, we can joint p' to q_{n+1} with a curve $J' \subset I$. Define $J^* = J \cup J'$. Then J^* is a connected curve in $W_X^u(p) \cap S$. Clearly, $J^* \cap l_S \neq \emptyset$, and so, we can assume that J^* has a boundary point $q^* \in l_S$ since l_S is closed and satisfies $l_S = (\Lambda \cap S) \setminus \text{Dom}(\Pi)$. Then, $J^* \subset \Lambda \cap S$ joints $q^* \in l_S$ to $p' \in \mathcal{O}_X(p)$ proving the result. \square

Corollary 1.4. *If both Λ and σ_S are attracting sets and $p \in \Lambda \setminus \sigma_S$ is a hyperbolic periodic point of X , then $W_X^u(p) \cap l_S = \emptyset$.*

Proof. By contradiction, suppose that $W_X^u(p) \cap l_S \neq \emptyset$ for some hyperbolic periodic point $p \in \Lambda \setminus \sigma_S$. Since σ_S is an attracting set by hypothesis, Lemma 1.1 implies that l_S is open and closed in $\Lambda \cap S$.

On the other hand, by the previous lemma, there is a connected curve $J^* \subset W_X^u(p) \cap S$ joining $q^* \in l_S$ to some point $p' \in \mathcal{O}_X(p) \cap S$. As Λ is an attracting set and $p \in \Lambda$, we have $J^* \subset \Lambda \cap S$. But, the connectness of J^* and the fact that l_S is open and closed in $\Lambda \cap S$ imply that $J^* \subset l_S$. In particular, $p' \in l_S$ and so $\omega_X(p') = \mathcal{O}_X(p) \subset \sigma_S$, a contradiction. \square

To complete the proof of Theorem 1.0 we use the following notation. If H is an invariant set of a vector field X , we say that $p \in H$ is *nonwandering* for X restricted to H if for any neighborhood $U \subset H$ of p and $T > 0$ there is $t > T$ so that $X_t(U) \cap U \neq \emptyset$. We denote $\Omega(X/H)$ the set of all nonwandering points of X restricted to H .

Proof of Theorem 1.0. Let S be a surface transverse to a hyperbolic connected attracting set Λ of a vector field X . Assume by contradiction that σ_S is an attracting set. Then, $\sigma_S \neq \emptyset$ and so there is $q \in l_S \neq \emptyset$ by Lemma 1.2. As σ_S is an attracting set, we have that $\exists q_0 \in \alpha_X(q) \cap S \neq \emptyset$. The point q_0 cannot belong to an attracting periodic orbit since $q \in l_S$. In particular, $W_X^s(q) \cap S$ has dimension one.

Observe that $q_0 \in \Omega(X/\Lambda)$. Then, by the Shadowing Lemma [PT], there exists a periodic point sequence $p_n \in \Lambda$ converging to q_0 . Note that this sequence is not in σ_S since $q_0 \notin \sigma_S$.

The Local Structure Product [PS] implies that the orbit of p_n is neither an attracting nor a repelling periodic orbit for n large since both p_n and the backward orbit of q approach q_0 . In particular, $W_X^u(p_n) \cap S$ has dimension one and there exists $q' \in W_X^s(q) \cap W_X^u(p_n) \cap S$ for n large enough.

So, for $p = p_n$ with n large enough, there is $q^* \in W_X^u(p) \cap l_S$ in the positive orbit of q' since q' is asymptotic to $q \in l_S$. This contradicts Corollary 1.4 since $p \in \Lambda \setminus \sigma_S$ (for $p_n \notin \sigma_S$) proving the result. \square

2. PROOF OF THEOREM A

The result of this section is

Theorem B. *Let Λ be a connected hyperbolic attracting set of a three-dimensional vector field with $\dim(E^u) = 1$. If Λ exhibits a transverse surface S such that \mathcal{F}_S^u has no closed leaves, then $\sigma_S = \emptyset$.*

Before its proof we give some examples.

Example 2.1. Let Λ be a hyperbolic strange attractor of a three-dimensional vector field. As transitive sets for flows are always connected, we conclude that Λ is a connected hyperbolic attracting set of a three-dimensional vector field with $\dim(E^u) = 1$. If Λ admits a transverse surface S so that \mathcal{F}_S^u has no closed leaves, the theorem above implies that Λ is a suspension because $\sigma_S = \emptyset$. This is the content of Theorem A.

Example 2.2. Let X be an Anosov flow defined on a closed 3-manifold M . Then, $\Lambda = M$ is obviously a connected hyperbolic attracting set of X with $\dim(E^u) = 1$. If X admits a transverse surface S so that the induced unstable foliation \mathcal{F}_S^u has no closed leaves, then we conclude that $\sigma_S = \emptyset$ by the above theorem. In particular, S is a torus and X is a suspension. This result was quoted in [Fe2] as mentioned in §1.

Example 2.3. Let Λ be a suspended hyperbolic attractor of a three-dimensional vector field X . Then every transverse surface of Λ is a cross-section of it. Indeed, let S_0 the cross-section of Λ and S be a transverse surface of Λ . We can assume that $\dim(E^u) = 1$. Clearly, $\Lambda^* = \Lambda \cap S_0$ is a hyperbolic attractor of the return map associated to S_0 . If S were not a cross-section, then \mathcal{F}_S^u would have a closed leave by the above theorem. This closed leave is carried by the flow into a closed leave in $\mathcal{F}_{S_0}^u$. One concludes that the unstable manifold of Λ^* would have a closed leave, a contradiction (see the proof of Theorem 8.1 in [R]). Thus $\sigma_S = \emptyset$ by Theorem A and so S is a cross-section as claimed.

We begin the proof of Theorem B with the following standard fact.

Lemma 2.1. *An isolated hyperbolic set without singularities H of a vector field X is an attracting set if $W_X^u(p) \subset H$ for any $p \in H$ periodic.*

Proof. By the Stable Manifold Theorem [HPS], it suffices to show that $U = \{x : \omega_X(x) \subset H\}$ is a neighborhood of H .

For this we proceed as follows. As H is isolated and hyperbolic, $\Omega(X/H)$ is a finite disjoint union $H_1 \cup \dots \cup H_n$ of basic sets by the Spectral Decomposition

Theorem [PS]. Remember that a compact invariant set B of X is *basic* if it is transitive, hyperbolic and isolated. Now, suppose that $\omega_X(x) \subset H$. Replacing x by a suitable point in $\omega_X(x)$ if necessary, we can assume that $\omega_X(x) \subset H_1$ (say).

As the periodic points are dense in H_1 , the positive orbit of x passes close to the orbit of some periodic point $p \in H_1$. Thus, the orbit of x must be asymptotic to the positive orbit of some point in $W_X^u(p) \subset H$. This clearly occurs for every point close to x and so U is open as claimed. This completes the proof of the lemma. \square

Now, let p be a hyperbolic periodic point of a vector field X with $\dim(E_p^u) = 1$. As already mentioned in the Introduction, there is a strong unstable manifold $W_X^{uu}(p)$ passing through p and tangent to E^u . In particular, $W_X^{uu}(p)$ is one-dimensional and contained in $W_X^u(p)$.

Denoting by t_p the period of p , one has $X_{t_p}(W_X^{uu}(p)) = W_X^{uu}(p)$. The map $X_{t_p}/W_X^{uu}(p)$ either preserves or reverses the orientation, and so, $W^u(p)$ is either a cylinder or a Moebius band respectively.

A *fundamental domain* for $W_X^{uu}(p)$ is a closed interval $[a, b]^{uu}$ contained in $W_X^{uu}(p)$ so that $a \neq p$ and either $X_{t_p}(a) = b$ (in the orientation-preserving case) or $X_{2t_p}(a) = b$ (in the orientation-reversing case).

Lemma 2.2. *Let S be a transverse surface of a hyperbolic attracting set Λ of a vector field X with $\dim(E^u) = 1$ and let $p \in \sigma_S$ be periodic. Suppose that a fundamental domain $[a, b]^{uu}$ of $W_X^{uu}(p)$ satisfies*

- (1) $X_t([a, b]^{uu}) \cap S = \emptyset$ for all $t \leq 0$ and
- (2) every positive orbit of X starting in $[a, b]^{uu}$ meets S .

Then, \mathcal{F}_S^u has a closed leaf.

Proof. The positive flow of X defines a first intersection map Π from $[a, b]^{uu}$ to S . As a is in the backward orbit of b and the backward saturation of the domain does not intersect S , we conclude that $\Pi(a) = \Pi(b)$. Thus $\Pi([a, b]^{uu})$ is a closed curve without self-intersections. By definition, this curve is a leaf of \mathcal{F}_S^u since it is contained in $W_X^u(p) \cap S$. \square

Before the proof of Theorem B let us remember some useful properties of basic sets B for vector fields X .

If B is nonsingular, it follows that B is the closure of the periodic orbits of X in B . In addition, if q is a point such that $\omega_X(q) \subset B$, then there is $x \in B$ such that $q \in W_X^{ss}(x)$. In other words, every point asymptotic to B is asymptotic to some point in B .

Next we recall the notion of a stable boundary point [NP], [Ch, Definition 2.6]. Let X be a three-dimensional vector field and B a nonsingular basic set of X with $\dim(E^u) = 1$. One says that $x \in B$ is a *stable boundary point* of B if there is an open interval $I \subset W_X^{uu}(x)$ containing x such that one of the connected components of $I \setminus \{x\}$ does not intersect B .

Proof of Theorem B. Let S be a transverse surface of a connected hyperbolic attracting set Λ of X so that $\dim(E^u) = 1$. We assume by the proof that \mathcal{F}_S^u has no closed leaves. \square

Under such conditions we prove

Lemma 2.3. *If $\sigma_S \neq \emptyset$, then σ_S is an attracting set.*

The proof of Theorem B using the above lemma is as follows: Since Λ is connected, we conclude that σ_S cannot be an attracting set by Theorem 1.0. Then, $\sigma_S = \emptyset$ by Lemma 2.3 and the proof follows.

We are left to prove Lemma 2.3 in order to prove Theorem B.

Proof of Lemma 2.3. By Lemma 2.1 it is enough to prove that $W_X^u(p) \subset \sigma_S$ for every $p \in \sigma_S$ periodic. Recall that σ_S is nonempty (by hypothesis) isolated and hyperbolic (Lemma 1.1). Moreover, Λ has no singularities since it is an attracting set and $\dim(E^u) = 1$. In particular, σ_S has no singularities.

By way of contradiction, assume the existence of $p_0 \in \sigma_S$ periodic and $q_0 \in W_X^u(p_0) \setminus \sigma_S$. We can assume that q_0 is a boundary point of a fundamental domain $I = [q_1, q_0]^{uu}$ of $W_X^{uu}(p_0)$ satisfying $I \cap S = \emptyset$. By definition of fundamental domain, q_1 is in the backward orbit of q_0 .

As Λ is an attracting set, $q_0 \in \Lambda$. Thus, there is a minimum positive number t so that $X_t(q_0) \in S$ because $q_0 \notin \sigma_S$. Then, there is a return map R from $D(R) \subset I$ (the domain of R) into S . Note that both q_0 and q_1 belong to $D(R)$ and $R(q_0) = R(q_1)$.

As Λ intersects S only in the interior of S , we have that $D(R)$ contains a maximal interval $J \subset I$ of the form $J = (q_1, q_0]$ for some $q_1 \leq q_2 < q_0$ (we order the points in I according to the natural interval order).

Observe that $q_1 < q_2$ since, otherwise, $I = J \subset D(R)$ and so the positive orbit of every point in I meets S . This would contradict Lemma 2.2 since \mathcal{F}_S^u has no closed leaves by hypothesis.

Note that $q_2 \in \sigma_S$ for its backward orbit converges to $\mathcal{O}_X(p_0)$, the orbit of p_0 , and its forward orbit cannot intersect S since J is maximal. In particular, $\omega_X(q_2)$ belongs to a basic set H in the spectral decomposition of $\Omega(X/\sigma_S)$. That such a decomposition exists follows from the fact that $\sigma_S \neq \emptyset$ is hyperbolic and isolated (Lemma 1.1). \square

Now we prove

Claim. *There is a periodic orbit $\mathcal{O} \subset H$ of X such that $q_2 \in W_X^s(\mathcal{O})$.*

Proof of the Claim. As H is a basic set and $\omega_X(q_2) \subset H$, we have that $q \in W_X^{ss}(x)$ for some $x \in H$. We shall prove that there is x' in the positive orbit of x such that x' is a stable boundary point of H (in particular x itself is a stable boundary point of H).

To prove this assertion, choose $y \in \omega_X(x)$ (thus $y \in H$). Let Σ be a transverse disc of X such that $y \in \text{int}(\Sigma)$, the interior of Σ . Choose a sequence $x_n \in \text{int}(\Sigma) \cap \mathcal{O}_X^+(x)$ converging to y . Fix $x' = x_n$ for some n large enough. Denote $F^s(x')$ (resp. $F^u(x')$) the connected component of $W_X^s(x') \cap \Sigma$ (resp. $W_X^u(x') \cap \Sigma$) containing x' . As the positive orbits of q_2 and x come together, one can choose $q_2' \in \mathcal{O}_X^+(q_2) \cap F^s(x')$.

By the Tubular Flow-Box Theorem there is a small interval $J' \subset J$ (with boundary point q_2) such that the flow of X carries J' into an interval $J'' \subset \text{int}(\Sigma)$ (with boundary point q_2'). Note that the closure of J'' and $F^s(x')$ intersect transversally at q_2' .

Now we suppose by contradiction that x' is not a stable boundary point of H . Then, there would exist $z \in H \cap F^u(x')$ arbitrarily close to x in both connected components of $F^u(x') \setminus \{x'\}$. Using the Local Product Structure of H ([PS]) and the fact that J'' intersects transversally $F^s(x')$ at q_2' , one could find $z \in H \cap F^u(x')$

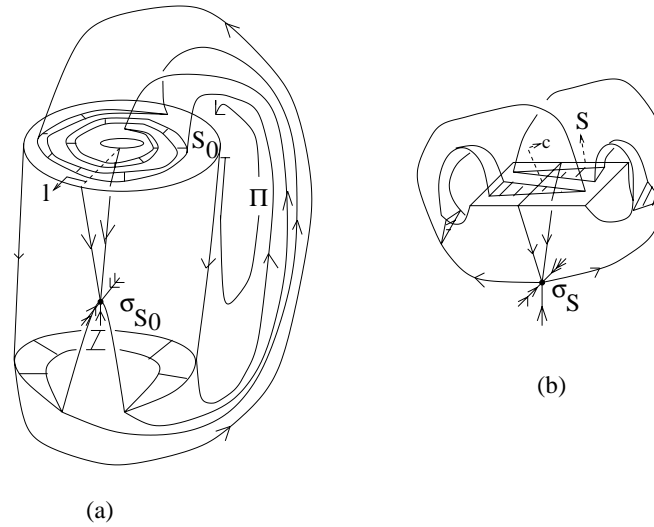

FIGURE 2.

such that $W_X^s(z) \cap J'' \neq \emptyset$. Taking $w \in W_X^s(z) \cap J'' \neq \emptyset$, we have that the positive orbit of w is asymptotic to that of $z \in H$. In particular, $\mathcal{O}_X^+(w) \cap S = \emptyset$. However, we have that $\mathcal{O}_X^+(w)$ intersects S by the definition of J (recall that $J' \subset J$ and J'' is in the positive orbit of J'). This contradiction proves that x' is a stable boundary point of H .

To finish the proof of the Claim we only need to observe that if B is a basic set of a three-dimensional vector field X , then every stable boundary point of B belongs to a periodic orbit of X ([NP, Proposition 1], [B, Lemme 1.12], [Ch, Lemma 2.7]). In particular, there is a periodic orbit $\mathcal{O} \subset H$ of X such that $x' \in W_X^s(\mathcal{O})$. As x' is in the positive orbit of x and $q_2 \in W_X^{ss}(x)$, it follows that $q_2 \in W_X^s(\mathcal{O})$. This proves the Claim. \square

To finish with the proof of Lemma 2.3, choose $J' \subset J$ as in the proof of the Claim. Then Inclination-Lemma [PT] implies that there is $x_0 \in \mathcal{O}$ such that the positive orbit of J' approaches a fundamental domain of $W_X^{uu}(x_0)$. As the positive orbit of $\text{int}(J')$ meets S , using the stable manifold of Λ , there is a fundamental domain of $W_X^{uu}(x_0)$ (very close to x_0) so that every positive orbit starting in that domain meets S . This last fact and Lemma 2.2 contradict once more the assumption that \mathcal{F}_S^u has no closed leaves. This contradiction completes the proof of Lemma 2.3.

3. EQUIVALENCE OF ATTRACTORS

In this section we apply §2 to study the topological equivalence between singular attractors with a transverse surface.

Let us first recall equivalence. Denote Λ and Λ' attractors for the flows X_t and X'_t respectively. We say that Λ and Λ' are *equivalent* if there are neighborhoods U and U' of Λ and Λ' respectively and a homeomorphism $H : U \rightarrow U'$ sending positively oriented X -orbits into positively oriented X' -orbits.

The following proposition will be used to study equivalence.

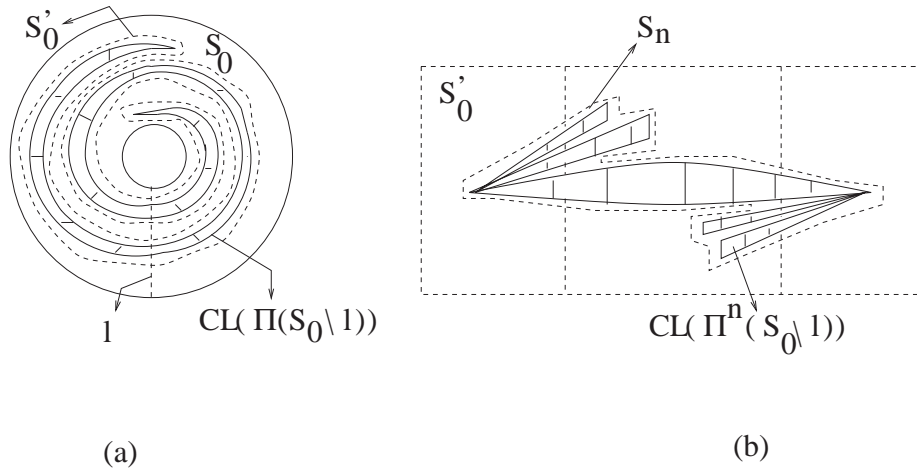

FIGURE 3.

Proposition 3.1. *If two transverse surfaces S and S' of an attractor Λ satisfy $\sigma_S = \sigma_{S'}$, then $\Lambda \cap S$ and $\Lambda \cap S'$ are homeomorphic.*

Proof. Observe that if $q \in \Lambda \cap S$, then $q \notin \sigma_S = \sigma_{S'}$ and so $X_{\mathbb{R}}(q) \cap S' \neq \emptyset$ by the definition of $\sigma_{S'}$. In particular, $\forall q \in \Lambda \cap S$ there is $t \in \mathbb{R}$ so that $X_t(q) \in S'$. This defines a return map R from $\Lambda \cap S$ into $\Lambda \cap S'$ which is clearly continuous and one-to-one. Interchanging the roles of S and S' in the argument, we obtain a continuous inverse for R . Thus R is a homeomorphism, and so, $\Lambda \cap S$ and $\Lambda \cap S'$ are homeomorphic finishing the proof. \square

We are going to consider the examples described in Figure 2. The one in Figure 2(b) is the well-known geometric Lorenz attractor in [GW]. We denote it by Λ and by X its underlying vector field. In this example there is a transverse surface S , the top rectangle indicated in that figure. Observe that σ_S is a singularity (see [GW] for details).

The example in Figure 2(a) comes from the Appendix in [MP]. Here, S_0 is a two-dimensional annulus and σ_{S_0} is a singularity as in the previous case. We denote by Λ_a the attractor of this figure and by X_a its underlying vector field.

Also indicated in Figure 2(a) is a return map Π , induced by the flow of X_a , from $S_0 \setminus l$ to the interior of S_0 . Here l denotes a curve contained in the stable manifold of σ_{S_0} . The map Π is hyperbolic: it expands along the angular direction and contracts along the radial one. The corresponding stable manifold's quotient in S_0 is the circle and the corresponding foliation map is transitive, i.e. has a dense orbit.

In Figure 3(a), S'_0 denotes a rectangular region which bounds $CL(\Pi(S_0 \setminus l))$. Figure 3(b) describes S'_0 in a precise way. There, S_n denotes a connected region which bounds the closure $CL(\Pi^n(S_0 \setminus l))$ of the successive Π -iterates of $S_0 \setminus l$, $n \in \mathbb{N}$. We can choose S_n arbitrarily close to $\Lambda_a \cap S_0$ as such iterates converge to $\Lambda_a \cap S_0$ in the Hausdorff topology.

Summarizing, we have the following properties for S_n :

1. $S_0 \cap \Lambda_a = S_n \cap \Lambda_a$,

2. $S_n \subset S_{n-1}$, for all n , and
3. S_n converges in the Hausdorff topology to $\Lambda_a \cap S_0$ as $n \rightarrow \infty$.

Let us see how these properties and Proposition 3.1 imply

Theorem 3.2. Λ_a and Λ are not equivalent.

As mentioned in §1 this result is claimed in [MP], but the proof there is just a sketch. The following proof fills in details of the proof in [MP] using the ideas developed in §2.

Proof. By Property (1) above we have that $\sigma_{S_0} = \sigma_{S_n}$ for all n . In particular, we can replace S_0 by S_n so that σ_{S_n} is still σ_{S_0} .

By way of contradiction, assume that there is an equivalence $H : U_a \rightarrow U$ from fixed neighborhoods U_a and U of Λ_a and Λ respectively. Then, $H(\Lambda_a) = \Lambda$ since Λ has no proper attractors and H is an equivalence.

Choosing n large, by Property (3), we can assume that $S_n \subset U_a$. Thus $S' = H(S_n)$ is well-defined. Using the equivalence, since S_n is a transverse surface of Λ_a , there is an open covering \mathcal{U} of S' so that every orbit of X in \mathcal{U} intersects S' only at one point. Then, we can modify S' using the flow of X to obtain a transverse surface of $H(\Lambda_a) = \Lambda$ still denoted by S' . Observe that $\sigma_{S'} = \sigma_S$ since H is an equivalence.

We conclude that $\Lambda \cap S'$ and $\Lambda \cap S$ are homeomorphic by Proposition 3.1. So, $\Lambda_a \cap S_n = H^{-1}(\Lambda \cap S')$ and $\Lambda \cap S$ are homeomorphic since H is a homeomorphism.

On the other hand, $\Lambda_a \cap S_n$ is a connected set. This follows from Property (1) together with the fact that every S_n is connected, the sequence S_n is nested (by Property (2)), and $\bigcap_n S_n = \Lambda_a \cap S_0$ (by Property (3)).

In particular, $\Lambda \cap S$ is connected since it is homeomorphic to $\Lambda_a \cap S_n$. But this is a contradiction since it is easy to check in Figure 2(b) that $\Lambda \cap S$ is not connected. Indeed, this set is separated by the two triangles depicted inside the top rectangle S in that figure.

We conclude that Λ and Λ_a cannot be equivalent, proving the result. \square

REFERENCES

- [B] Beguin, F., *Champs de vecteurs hyperboliques en dimension 3*, Thèse Université de Bourgogne (1999).
- [BW] Birman, J., Williams, R., *Knotted periodic orbits in dynamical systems II : Knot holders for fibered knots*, Low-dimensional Topology, Contemp. Math. **20**, Amer. Math. Soc., Providence, R. I., (1983), 1-60. MR **86a**:58084
- [BL] Bonatti, C., Langevin, R., *Un exemple de flot d'Anosov transitif transverse à un tore et non conjugué à une suspension*, Ergod. Theory Dynam. Sys. **14** (1994), 633-643. MR **95j**:58129
- [Bo] Bowen, R., *Mixing Anosov flows*, Topology **15** (1976), 77-79. MR **52**:11999
- [Ch] Christy, J., *Intransitive Anosov Flows on three-manifolds*, Thesis, Berkeley (1984).
- [Fe1] Fenley, S., *Surface transverse to pseudo-Anosov flows and virtual fiber in 3-manifolds*, Topology **38** (1999), 823-859. MR **2001a**:57041
- [Fe2] Fenley, S., *Incompressible tori transverse to Anosov flows in 3-manifolds*, Ergod. Theory Dynam. Sys. **17** (1997), 105-121. MR **98c**:58122
- [Fr] Fried, D., *The geometry of cross sections to flows*, Topology **21** (1982), 353-371. MR **84d**:58068
- [GW] Guckenheimer, J., Williams, R.F., *Structural stability of Lorenz attractor*, Publ. Math. IHES **50** (1979), 59-72. MR **82b**:58055a
- [HPS] Hirsch, M., Pugh, C., Shub, M., *Invariant manifolds*, Lecture Notes in Math. **583** (1977), Springer-Verlag. MR **58**:18595

- [NP] Newhouse, S., Palis, J., *Hyperbolic nonwandering sets on two-dimensional manifolds*, Dynamical Systems, Peixoto (Ed.), Salvador, (1973), 293-301. MR **49**:4044
- [MP] Morales, C. A., Pujals, E. R., *Singular strange attractors on the boundary of Morse-Smale systems*, Ann. Ec. Norm. Sup., **30** (1997), 693- 717. MR **98k**:58137
- [PT] Palis, J., Takens, F., *Hyperbolicity and sensitive chaotic dynamics at homoclinic bifurcations*, (1993), Cambridge Univ. Press. MR **94h**:58129
- [PS] Pugh, C., Shub, M., *The Ω -stability theorem for flows*, Inventiones Math. **11** (1970), 150-158. MR **44**:4782
- [R] Robinson, C., *Dynamical Systems*, Stability, symbolic dynamics, and chaos, Studies in Advanced Mathematics CRC Press, Boca Raton, FL (1995). MR **97e**:58064

INSTITUTO DE MATEMATICA, UNIVERSIDADE FEDERAL DO RIO DE JANEIRO, C. P. 68.530, CEP 21.945-970, RIO DE JANEIRO, BRAZIL

Current address: Universidad Centroccidental Lizandro Alvarado, Departamento de Matemática, Decamato de Ciencias, Apdo 400, Barquisimeto, Venezuela

E-mail address: wilmerc@pg.im.ufrj.br

INSTITUTO DE MATEMATICA, UNIVERSIDADE FEDERAL DO RIO DE JANEIRO, C. P. 68.530, CEP 21.945-970, RIO DE JANEIRO, BRAZIL

E-mail address: morales@impa.br