

3-MANIFOLDS THAT ADMIT KNOTTED SOLENOIDS AS ATTRACTORS

BOJU JIANG, YI NI, AND SHICHENG WANG

ABSTRACT. Motivated by the study in Morse theory and Smale’s work in dynamics, the following questions are studied and answered: (1) When does a 3-manifold admit an automorphism having a knotted Smale solenoid as an attractor? (2) When does a 3-manifold admit an automorphism whose non-wandering set consists of Smale solenoids? The result presents some intrinsic symmetries for a class of 3-manifolds.

1. INTRODUCTION

The solenoids were first defined in mathematics by Vietoris in 1927 for 2-adic case and by others later in general case, which can be presented either in an abstract way (inverse limit of self-coverings of circles) or in a geometric way (nested intersections of solid tori). The solenoids were introduced into dynamics by Smale as hyperbolic attractors in his celebrated paper [S].

Standard notions in dynamics and in 3-manifold topology will be given in Section 2. The new definitions are the following:

Let $N = S^1 \times D^2$, where S^1 is the unit circle and D^2 is the unit disc. Both S^1 and D^2 admit “linear structures”. Let $e : N \rightarrow N$ be a “linear”, D^2 -level-preserving embedding such that (a) $e(S^1 \times *)$ is a w -string braid in N for each $* \in D^2$, where $w > 1$ in an integer; (b) for each $\theta \in S^1$, the radius of $e(\theta \times D^2)$ is $1/w^2$.

Definition. Let M be a 3-manifold and let $f : M \rightarrow M$ be a diffeomorphism. If there is a solid torus $N \subset M$ such that $f|N$ (resp. $f^{-1}|N$) conjugates $e : N \rightarrow N$ above, we call $S = \bigcap_{h=1}^{\infty} f^h(N)$ (resp. $S = \bigcap_{h=1}^{\infty} f^{-h}(N)$) a *Smale solenoid*, which is a hyperbolic attractor (resp. repeller, or negative attractor) of f , and we also say M admits S as a Smale solenoid attractor and N is a defining solid torus of S .

Smale solenoid in the above definition carries more information than a solenoid as a topological space. It also carries the information of braiding of $e(N)$ in N and the knotting and framing of N in M , in addition to the information that it is a hyperbolic attractor of a diffeomorphism $f : M \rightarrow M$.

Say a Smale solenoid $S \subset M$ is *trivial* if the core of a defining solid torus N bounds a disc in M , otherwise say S is *knotted*.

Received by the editors February 20, 2003 and, in revised form, April 18, 2003.

2000 *Mathematics Subject Classification.* Primary 57N10, 58K05, 37E99, 37D45.

Key words and phrases. 3-manifolds, homeomorphisms, attractors, solenoids, lens spaces.

This work was partially supported by a MOSTC grant and a MOEC grant.

Theorem 1. *Suppose M is a closed orientable 3-manifold. There is a diffeomorphism $f : M \rightarrow M$ such that the non-wandering set $\Omega(f)$ contains a knotted Smale solenoid IF and ONLY IF the manifold M has a lens space $L(p, q)$, with $p \neq 0, \pm 1$, as a prime factor.*

Theorem 2. *Suppose M is a closed orientable 3-manifold. There is a diffeomorphism $f : M \rightarrow M$ with the non-wandering set $\Omega(f)$ a union of finitely many Smale solenoids IF and ONLY IF the manifold M is a lens space $L(p, q)$, $p \neq 0$.*

Moreover for the IF part, the $\Omega(f)$ can be chosen to be two explicit $(p + 1)$ -adic solenoids, $p + 1 \neq 0, \pm 1$.

Corollary 1. *The diffeomorphism f constructed in the IF part of Theorem 2 is Ω -stable, but is not structurally stable.*

Motivations of the results.

(1) *From Morse theory.* Let $f : M \rightarrow R$ be a non-degenerate Morse function. Then the gradient vector field $\text{grad}f$ is a dynamical system on M with hyperbolic $\Omega(\text{grad}f)$. An important aspect of Morse theory is to use the global information of the singularities of f , or equivalently, the information of $\Omega(\text{grad}f)$, to provide topological information of the manifold M . The classical examples are: if $\Omega(\text{grad}f)$ consists of two points, then M is the sphere by Reeb in 1952 [R], and if $\Omega(\text{grad}f)$ consists of three points, then M is a projective plane like manifold of dimension 2, 4, 8 or 16 proved by Eells and Kuiper in 1961 [EK]. The ONLY IF part of Theorems 1 and 2 are results of this style.

(2) *From dynamics of Smale's school.* In [S], for a diffeomorphism $f : M \rightarrow M$, Smale introduced the Axiom A, the strong transversality condition and the no cycle condition for $\Omega(f)$. Important results in the dynamics school of Smale are the equivalences between those conditions and various stabilities. For an Axiom A system f , Smale proved (Spectral Decomposition Theorem) $\Omega(f)$ can be decomposed into the so-called basic sets. He posed several types of basic sets: (a) Zero dimensional ones such as isolated points and Smale Horse Shoe; (b) Anosov maps and maps derived from Anosov; (c) expansive ones such as Smale solenoids.

All those results and notions need examples to testify. Most known examples are local. It is natural to ask a global question where topology and dynamics interact: For which manifold M is there an $f : M \rightarrow M$ such that all the basic sets of $\Omega(f)$ belong to a single type above?

There is no restriction when $\Omega(f)$ is zero dimensional. The answer to the question for Anosov map was given by Porteous in 1974 [Po]. The ONLY IF part of Theorem 2 gives an answer about Smale solenoids for 3-manifolds. The Corollary also provides 3-dimensional global examples to testify the notions of stability.

We would also like to point out that there are many nice results on the interplay of topology and dynamics, mostly for flows. See [F], [Su] and [T] for examples.

(3) *Searching symmetries of manifolds with stability.* A manifold M admitting a dynamics f such that $\Omega(f)$ consists of two hyperbolic attractors presents a symmetry of the manifold with certain stability. The sphere, the simplest closed manifold, admits a hyperbolic dynamics f such that $\Omega(f)$ consists of exactly two points, one is a source, and the other is a sink. The attractors in this example are the simplest in three senses: (1) The topology of the attractors are trivial, (2) the embedding

of attractors into the manifolds are trivial, (3) the restriction of the dynamics f on the attractors are trivial. The IF part of Theorem 2 and the Corollary show more manifolds with such symmetry when we consider more complicated attractors suitably embedded into the manifolds.

Indeed we believe that many more 3-manifolds admit such symmetries if we replace the Smale solenoid by its generalization, the so-called *Smale-Williams solenoid* [W] (the name is suggested in [Pe]).

The structure of the paper. For the convenience of the readers from both dynamics and 3-manifold topology, we list the needed notions and facts in dynamics and in 3-manifold topology in Section 2. Sections 3, 4 and 5 are devoted respectively to the proofs of the ONLY IF parts of Theorems 1 and 2, the IF parts of Theorems 1 and 2, and the Corollary. Most notions in dynamics mentioned in Section 2 are only used in Section 5. To the authors, the most interesting part of the paper is the discovery of the IF part of Theorem 2 and its explicit constructive proof. Since such an explicit constructive proof is difficult to generalize to the case of Smale-Williams solenoids, we wonder if there is an alternative proof for the IF part of Theorem 2.

2. NOTIONS AND FACTS IN DYNAMICS AND IN 3-MANIFOLD TOPOLOGY

From dynamics. Everything in this part can be found in [Ni], unless otherwise indicated.

Assume $f : M \rightarrow M$ is a diffeomorphism of a compact n -manifold M .

An *invariant set* of f is a subset $\Lambda \subset M$ such that $f(\Lambda) = \Lambda$. A point $x \in M$ is *non-wandering* if for any neighborhood U of x , $f^n(U) \cap U \neq \emptyset$ for infinitely many integers n . Then $\Omega(f)$, the *non-wandering set* of f , defined as the set of all non-wandering points, is an f -invariant closed set. A set $\Lambda \subset M$ is an *attractor* if there exists a closed neighborhood U of Λ such that $f(U) \subset \text{Int } U$, $\Lambda = \bigcap_{h=1}^{\infty} f^h(U)$, and $\Lambda = \Omega(f|U)$.

Say f is *structurally stable* if all diffeomorphisms C^1 -close to f are conjugate to f . Say f is Ω -*stable* if all diffeomorphisms C^1 -close to f preserve the structure of $\Omega(f)$.

A closed invariant set Λ of f is *hyperbolic* if there is a continuous f -invariant splitting of the tangent bundle TM_Λ into *stable* and *unstable bundles* $E_\Lambda^s \oplus E_\Lambda^u$ with

$$\begin{aligned} \|Df^m(v)\| &\leq C\lambda^{-m}\|v\| \quad \forall v \in E_\Lambda^s, \forall m > 0, \\ \|Df^{-m}(v)\| &\leq C\lambda^{-m}\|v\| \quad \forall v \in E_\Lambda^u, \forall m > 0, \end{aligned}$$

for some fixed $C > 0$ and $\lambda > 1$.

The Axiom A. *The diffeomorphism $f : M \rightarrow M$ satisfies Axiom A if (a) the non-wandering set $\Omega(f)$ is hyperbolic; and (b) the periodic points of f are dense in $\Omega(f)$.*

Spectral Decomposition Theorem. *For $f : M \rightarrow M$ satisfying Axiom A, $\Omega(f)$ can be decomposed in a unique way into finitely many disjoint sets B_1, \dots, B_k , so that each B_i is closed, f -invariant and contains a dense f -orbit.*

The B_i in the decomposition above are usually referred to as *basic sets*.

Stable Manifold Theorem. *Suppose $\Omega(f)$ is hyperbolic. Then for each $x \in \Omega(f)$, the sets $W^s(x, f) = \{y \in M \mid \lim_{j \rightarrow \infty} d(f^j(y), f^j(x)) = 0\}$ and $W^u(x, f) = \{y \in M \mid \lim_{j \rightarrow \infty} d(f^{-j}(y), f^{-j}(x)) = 0\}$ are smooth, injective immersions of the E_x^s and E_x^u , respectively. Moreover, they are tangent to E_x^s and E_x^u at x , respectively.*

$W^s(x, f)$ and $W^u(x, f)$ in the theorem are known as the *stable and unstable manifolds of f at x* .

The Strong Transversality Condition. *For all $x, y \in \Omega(f)$, the stable and unstable manifolds $W^s(x, f)$ and $W^u(y, f)$ are transverse.*

The no cycle condition. An n -cycle of the Axiom A system is a sequence of basic sets $\Omega_0, \Omega_1, \dots, \Omega_n$ with $\Omega_0 = \Omega_n$ and $\Omega_i \neq \Omega_j$ otherwise, and such that $W^u(\Omega_{i-1}) \cap W^s(\Omega_i) \neq \emptyset$. An Axiom A system satisfies the *no-cycle condition* if it has no n -cycle for all $n \geq 1$.

Stability theorem (See the survey paper [Ha]). (a) *Axiom A and the strong transversality condition of $\Omega(f)$ are equivalent to the structural stability of f .*

(b) *Axiom A and the no cycle condition of $\Omega(f)$ are equivalent to the Ω -stability of f .*

From 3-manifold theory. Everything in this part can be found in [He], unless otherwise indicated.

Let M be a 3-manifold and S an embedded 2-sphere separating M . Let M_1 and M_2 be the two 3-manifolds obtained by splitting M along S and capping-off the two resulting 2-sphere boundary components by two 3-cells. Then M is a *connected sum* of M_1 and M_2 , written $M_1 \# M_2$.

A 3-manifold $M \neq S^3$ is *prime* if $M = M_1 \# M_2$ implies one of M_1, M_2 is S^3 .

Let F be a connected compact 2-sided surface properly embedded in M . F is said to be *compressible* if either F bounds a 3-ball, or there is an essential, simple closed curve on F which bounds a disk in M ; otherwise, F is said to be *incompressible*.

The following three results in 3-manifold topology are fundamental.

Kneser-Milnor's Prime Decomposition Theorem. *Every closed orientable 3-manifold $M \neq S^3$ can be expressed as a connected sum of a finite number of prime factors. Furthermore, the decomposition is unique up to order and homeomorphism.*

Haken's Finiteness Theorem. *Let M be a compact orientable 3-manifold. Then the maximum number of pairwise disjoint, non-parallel, closed connected incompressible surfaces in M , denoted by $h(M)$, is a finite integer ≥ 0 .*

Papakyriakopoulos's Loop Theorem. *Let M be a compact orientable 3-manifold and $S \subset M$ a closed orientable surface. If the homomorphism $i_* : \pi_1(S) \rightarrow \pi_1(M)$ induced by the embedding $i : S \rightarrow M$ is not injective, then there is an embedded disc $D \subset M$ such that $D \cap S = \partial D$ and ∂D is an essential circle in S .*

For the definition of the *lens space* $L(p, q)$, see Section 4.

3. PROOF OF THE ONLY IF PARTS OF THEOREMS 1 AND 2

We first prove the ONLY IF part of Theorem 1.

Proof. Suppose $f : M \rightarrow M$ has a knotted Smale solenoid S as an attractor. Then $S = \bigcap_{h=1}^{\infty} f^h(N)$, and $\overline{M - N} \subset M - f(N)$, where N is a defining solid torus of S .

Since f is a global homeomorphism, $\overline{M - N}$ and $\overline{M - f(N)}$ are homeomorphic. Suppose first that $\partial\overline{M - N}$ is an incompressible surface in $\overline{M - N}$. By Haken's Finiteness Theorem, $h(M)$, the maximum number of pairwise disjoint, non-parallel, closed incompressible surfaces in M , is a finite integer. Since the winding number w of $\overline{f(N)}$ in N is > 1 , $\partial\overline{M - N}$ is incompressible in $\overline{N - f(N)}$ and is not parallel to $\partial\overline{M - f(N)}$. It follows that for any set F of disjoint, non-parallel, incompressible surfaces of $\overline{M - N}$, $\partial\overline{M - f(N)} \cup F$ is a set of disjoint non-parallel closed incompressible surfaces in $\overline{M - f(N)}$. Hence $h(\overline{M - f(N)})$ is larger than $h(\overline{M - N})$, which contradicts the fact that $\overline{M - N}$ and $\overline{M - f(N)}$ are homeomorphic.

By the last paragraph, $\partial\overline{M - N}$ is compressible in $\overline{M - N}$. This means there is a properly embedded disc $(D, \partial D) \subset (\overline{M - N}, \partial\overline{M - N})$ such that ∂D is an essential circle in ∂N . Cutting $\overline{M - N}$ along D , we get a 3-manifold, denoted by M_1 , with ∂M_1 a 2-sphere containing two copies D_1 and D_2 of D . Let S_* be a boundary parallel 2-sphere in the interior of M_1 . Now identifying D_1 and D_2 , we get back to $\overline{M - N}$ and S_* separates a punctured solid torus from $\overline{M - N}$; finally we glue back N with $\overline{M - N}$ to get M and S_* separates a punctured lens space from M , i.e., M contains a lens space L as a prime factor.

If L is S^3 , then it is easy to see the core of N bounds a disc, which contradicts the assumption that S is knotted. If $L = S^2 \times S^1$, then N carries a generator α of $\pi_1(S^2 \times S^1) = Z$. Since $f(N)$ is a w -string braid in N , we have $f_*(\alpha) = w\alpha$. Since f is a homeomorphism, f_* is an isomorphism. Hence $w = 1$, and we reach a contradiction.

We have finished the proof of the ONLY IF part of Theorem 1. □

We are going to prove the ONLY IF part of Theorem 2.

Suppose $\Omega(f)$ is a union of Smale solenoids S_1, \dots, S_n . Then for each $i = 1, \dots, n$, it is known (more or less directly from the definition) that

- (i) $f|_{S_i}$ is hyperbolic and the periodic points of f are dense in S_i ;
- (ii) S_i is an f -invariant closed set and there is a dense f -orbit in S_i .

Then f satisfies Axiom A by (i). By Spectral Decomposition Theorem, $\Omega(f)$ can be decomposed in a unique way into finitely many disjoint basic sets B_1, \dots, B_k , so that each B_i is closed, f -invariant and contains a dense f -orbit.

By (ii), each $S_i \subset B_l$ for some $l = 1, \dots, k$. Then from the facts that S_i is an attractor of f (or of f^{-1}) and that B_l contains a dense f -orbit, there is a point $x \in \text{Int } U_i$ so that its f -orbit $o(x)$ is dense in B_l , where U_i is a closed neighborhood of S_i mentioned in the definition of an attractor. Then it is clear that $x \in \Omega(f|_{U_i})$. Hence $x \in S_i$, thus $B_l = o(x) \subset S_i$, so we must have $S_i = B_l$. Hence each S_i is a basic set of $\Omega(f)$ and in particular, $\Omega(f)$ is a disjoint union of finitely many Smale solenoids.

Now the ONLY IF part of Theorem 2 follows from Lemma 1 and Lemma 2 below.

Lemma 1. *Suppose $f : M \rightarrow M$ is a diffeomorphism and $\Omega(f)$ is a disjoint union of finitely many Smale solenoids. Then $\Omega(f)$ is a union of two solenoids, one is an attractor of f and the other is an attractor of f^{-1} .*

Proof. Suppose

$$(1) \quad \Omega(f) = S_1 \cup S_2 \cup \dots \cup S_n, \quad n \geq 1,$$

is a disjoint union of solenoids, where either $S_i = \bigcap_{h=1}^{\infty} f^h(N_i)$ if S_i is an attractor of f or $S_i = \bigcap_{h=1}^{\infty} f^{-h}(N_i)$ if S_i is an attractor of f^{-1} . Without loss of generality,

we assume that the N_i 's have been chosen so that $N_i \cap N_j = \emptyset$ if $i \neq j$ (since $S_i \cap S_j = \emptyset$ for $i \neq j$), and some S_i is an attractor of f (otherwise replace f by f^{-1}). Then by re-indexing if necessary we assume that S_1, \dots, S_k are attractors of f and the remaining S_j are attractors of f^{-1} ; henceforth, k is the number of attracting solenoids. So we can assume

$$(2) \quad f(N_i) \subset \text{Int } N_i, \quad i = 1, \dots, k \leq n,$$

and

$$(3) \quad f^{-1}(N_j) \subset \text{Int } N_j, \quad j = k + 1, \dots, n.$$

For $i = 1, \dots, k$, let $V_i = \bigcup_{h=1}^{\infty} f^{-h}(\text{Int } N_i)$. Since f is a homeomorphism, V_i is open. Moreover

$$(4) \quad V_i \cap V_j = \emptyset, \quad 1 \leq i < j \leq k,$$

and

$$(5) \quad f(V_i) = V_i,$$

by the assumptions (2) and $N_i \cap N_j = \emptyset$ for $i \neq j$.

First we suppose $n = 1$. Now Let $Y_1 = M - \text{Int } N_1$. Then Y_1 is compact and $f^{-1}(Y_1) \subset Y_1$ by (2). Therefore $\Omega(f) = \Omega(f^{-1})$ intersects Y_1 , which contradicts (1).

So $n > 1$. Suppose $k > 1$. Let $Y_2 = M - \bigcup_{j=k+1}^n S_j$. For each $i = 1, \dots, k$, $V_i \subset Y_2$. Y_2 is connected, so it cannot be a disjoint union of $k > 1$ open sets. Hence $Y_3 = M - ((\bigcup_{j=k+1}^n S_j) \cup (\bigcup_{i=1}^k V_i))$ is not empty. Suppose $x \in Y_3$. Since S_j is compact, we can choose N_j sufficiently small in order that $x \notin \bigcup_{j=k+1}^n \text{Int } N_j$. Then $Y_4 = M - ((\bigcup_{j=k+1}^n \text{Int } N_j) \cup (\bigcup_{i=1}^k V_i))$ is compact and is not empty. By (3), (5), we have $f(Y_4) \subset Y_4$. Hence $\Omega(f) \cap Y_4 \neq \emptyset$, a contradiction.

We have proved that f has exactly one attractor. By the same reason f^{-1} also has exactly one attractor, therefore $n = 2$ and the lemma is proved. \square

Lemma 2. *Let M be a closed orientable 3-manifold. If $f : M \rightarrow M$ is a diffeomorphism with $\Omega(f)$ a union of two disjoint Smale solenoids, then M is a lens space and M is not $S^2 \times S^1$.*

Proof. Suppose $\Omega(f)$ is a union of two disjoint solenoids S_1 and S_2 . We may further assume that

$$(6) \quad S_1 = \bigcap_{h=1}^{\infty} f^h(N_1), \quad S_2 = \bigcap_{h=1}^{\infty} f^{-h}(N_2), \quad N_1 \cap N_2 = \emptyset.$$

We have $\bigcup_{h=1}^{\infty} f^{-h}(\text{Int } N_1) = M - S_2$. It follows that

$$(7) \quad f^n(\partial N_2) \subset \text{Int } N_1, \quad M - N_1 \subset f^n(N_2) \quad \text{for some large integer } n > 1.$$

Since $H_2(N_1, Z) = 0$, $\partial f^n(N_2)$ separates N_1 into two parts Y' and Y'' with $\partial Y' = \partial f^n(N_2)$ and $\partial Y''$ has two components.

The homomorphism $i_* : \pi_1(\partial f^n(N_2)) \rightarrow \pi_1(N_1)$ induced by the embedding $i : \partial f^n(N_2) \rightarrow N_1$ is not injective, since $\pi_1(N_1) = Z$ and $\pi_1(\partial f^n(N_2)) = Z \oplus Z$. By the Loop Theorem, $\partial f^n(N_2)$ is compressible in N_1 , that is, there is an embedded disc $D \subset N_1$ such that $D \cap \partial N_2 = \partial D$ and ∂D is an essential circle in $\partial f^n(N_2)$. Since the solid torus N_1 is irreducible, a standard argument shows that $\partial f^n(N_2)$

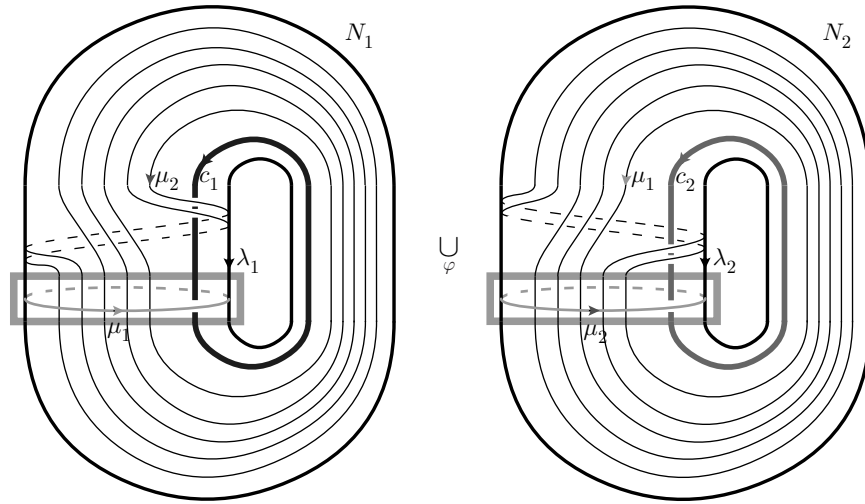

FIGURE 1. Lens space $L(p, q)$ as union of solid tori $N_1 \cup_{\varphi} N_2$

bounds a solid torus N' in N_1 , and therefore we have $N' = Y'$. Then by (7), we have

$$(8) \quad M = (M - N_1) \cup_{\partial N_1} N_1 = M - N_1 \cup_{\partial N_1} Y'' \cup_{\partial f^n(N_2)} Y' = f^n(N_2) \cup_{\partial f^n(N_2)} N'.$$

Hence M is obtained by identifying two solid tori $f^n(N_2)$ and N' along their common boundary. So M is a lens space.

Since f is a homeomorphism, $N'' = f^{-n}(N')$ is also a solid torus and M is obtained by identifying two solid tori N_2 and N'' along their boundary. Now $f^{-1}(N_2)$ is a w -string braid in N_2 , $w > 1$. That M is not $S^2 \times S^1$ can be proved as before. \square

4. PROOF OF THE IF PARTS OF THEOREMS 1 AND 2

Suppose M is the lens space $L(p, q)$, where $p > 0$ and $\gcd(p, q) = 1$. Then M is the union of two solid tori, $M = N_1 \cup_{\varphi} N_2$, where the gluing map $\varphi : \partial N_2 \rightarrow \partial N_1$ is an orientation reversing homeomorphism. On each torus ∂N_i , pick a meridian-longitude pair, denoted $\{\mu_i, \lambda_i\}$, as a basis of $H_1(\partial N_i)$. In ∂N_1 , $\varphi(\mu_2)$ is the (p, q) -curve, that is $\varphi(\mu_2) = p\lambda_1 + q\mu_1$, while $\varphi(\lambda_2) = r\lambda_1 + s\mu_1$, with $ps - qr = 1$. It is clear that in ∂N_1 we have $\varphi^{-1}(\mu_1) = p\lambda_2 - r\mu_2$ and $\varphi^{-1}(\lambda_1) = -q\lambda_2 + s\mu_2$. In Figure 1, the case of $M = L(5, 2)$ and $\begin{pmatrix} p & q \\ r & s \end{pmatrix} = \begin{pmatrix} 5 & -2 \\ -2 & 1 \end{pmatrix}$ is shown as a concrete example.

Proof of the IF part of Theorem 2. The IF part of Theorem 2 is equivalent to the following

Claim. *Suppose M is a lens space $L(p, q)$, $p > 0$. Then there is a diffeomorphism $f : M \rightarrow M$ with $\Omega(f)$ a union of two $(p + 1)$ -adic solenoids, one is an attractor, the other is a repeller.*

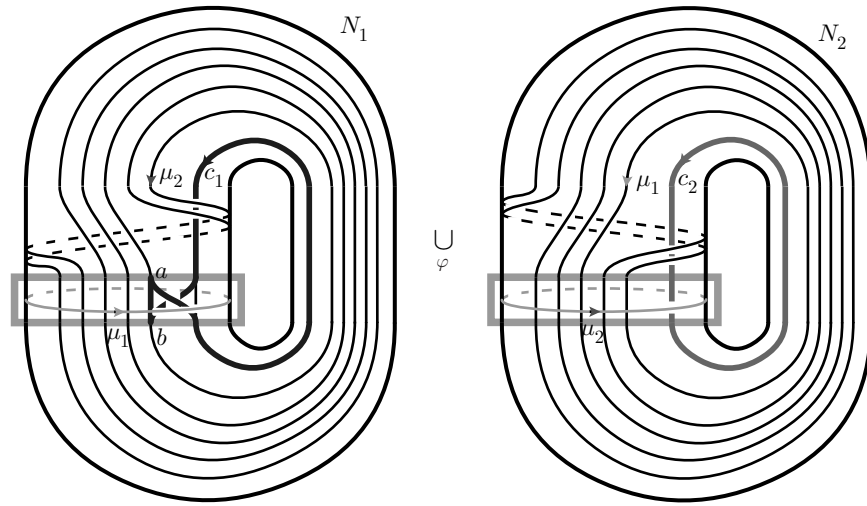

FIGURE 2. Writhe the core c_1 in N_1

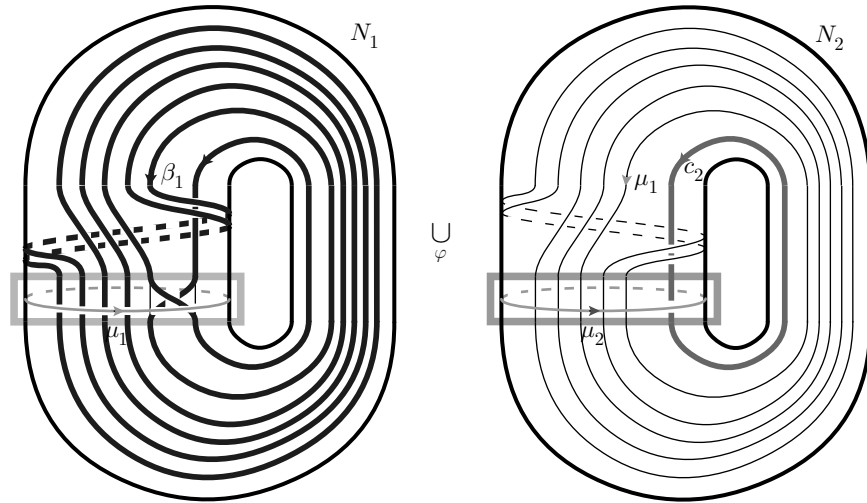

FIGURE 3. Closed braid β_1 in N_1 and core c_2 of N_2

We are going to prove this Claim.

Denote the oriented cores of N_1, N_2 by c_1, c_2 (c_i is homologous to λ_i in N_i), respectively. We do the following operations to c_1 , as indicated in Figure 2: Writhe c_1 locally, moving a subarc \overline{ab} toward ∂N_1 and identify it with a subarc of $\varphi(\mu_2)$. Since μ_2 bounds a meridian disk in N_2 , we can push \overline{ab} across the disk. The effect seen in N_1 is to replace \overline{ab} with its complement in $\varphi(\mu_2)$; see Figure 2. Finally, pushing the obtained curve into $\text{Int } N_1$, we get a closed braid β_1 in N_1 , as indicated in Figure 3. (In fact, β_1 is the “connected sum” of the “writhe” c^{-1} with $\varphi(\mu_2)$)

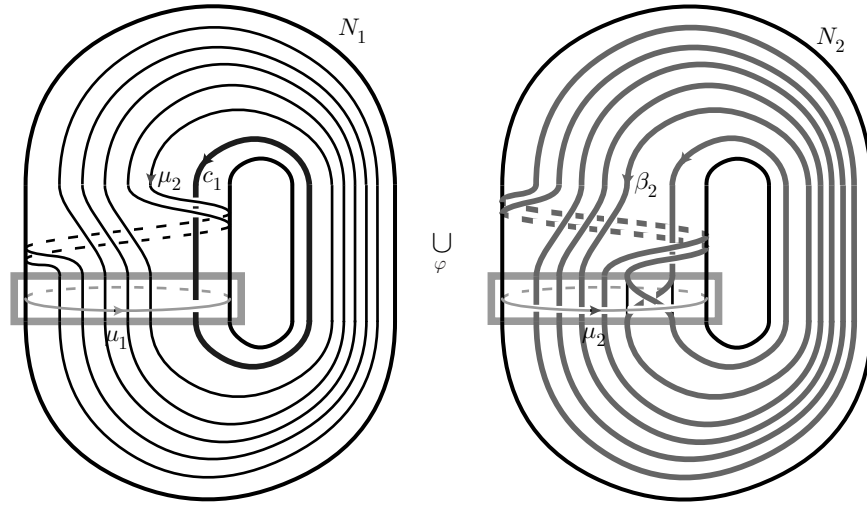

FIGURE 4. Core c_1 of N_1 and closed braid β_2 in N_2

in N_1 .) Applying similar operations to c_2 in N_2 , we get a closed braid β_2 in N_2 , as indicated in Figure 4. Now $\beta_1 \sqcup c_2$ and $c_1 \sqcup \beta_2$ are two links in M .

Lemma 3. *The two links $\beta_1 \sqcup c_2$ and $c_1 \sqcup \beta_2$ are isotopic in M .*

Proof. Recall that β_1 is obtained by isotoping c_1 ; thus if we perform the inverse of the above isotopy, we can transform β_1 into c_1 . We will show that the same isotopy also transforms c_2 into β_2 .

From now on, we only use local pictures (represented in the rectangular frame in Figures 1–4) to show changes in both N_1 and N_2 simultaneously. The initial local picture of $\beta_1 \sqcup c_2$ is shown in Figure 5-1. In N_1 (on the left), β_1 is a closed braid in N_1 , and a segment of c_2 is shown outside of ∂N_1 . On the right, most of β_1 coincides with μ_2 , along with the part slightly outside ∂N_2 , and c_2 is the core of N_2 . Our isotopy consists of the following three steps:

STEP 1. μ_2 bounds a meridian disk in N_2 , so we can pull β_1 across the disk. At the same time, a subarc of c_2 is pulled into N_1 , as indicated in Figure 5-2.

STEP 2. In the local picture Figure 5-2, β_1 has a self-crossing. A local half-twist will eliminate this self-crossing, as indicated in Figure 5-3. Take care so that a subarc \overline{cd} of c_2 lies on $\varphi^{-1}(\mu_1)$. Now comparing Figure 5-2 and Figure 5-3, we find an interesting fact: except for the colors and labels, the left/right part of Figure 5-2 is the same as the right/left part of Figure 5-3. This symmetry suggests that the next step is a kind of inverse to Step 1.

STEP 3. Push the subarc \overline{cd} across the meridian disk of N_1 , as indicated in Figure 5-4. We see that β_1 is deformed to c_1 , and c_2 is deformed to β_2 . \square

Proof of the Claim. Note that β_i is a $(p + 1)$ -string braid in $N_i = S^1 \times D_i^2$. Isotope β_i in N_i to meet all fiber discs $* \times D_i^2$ transversely. Let $\mathcal{N}(\gamma)$ denote the closed tubular neighborhood of a closed curve γ , and think of N_i as $\mathcal{N}(c_i)$.

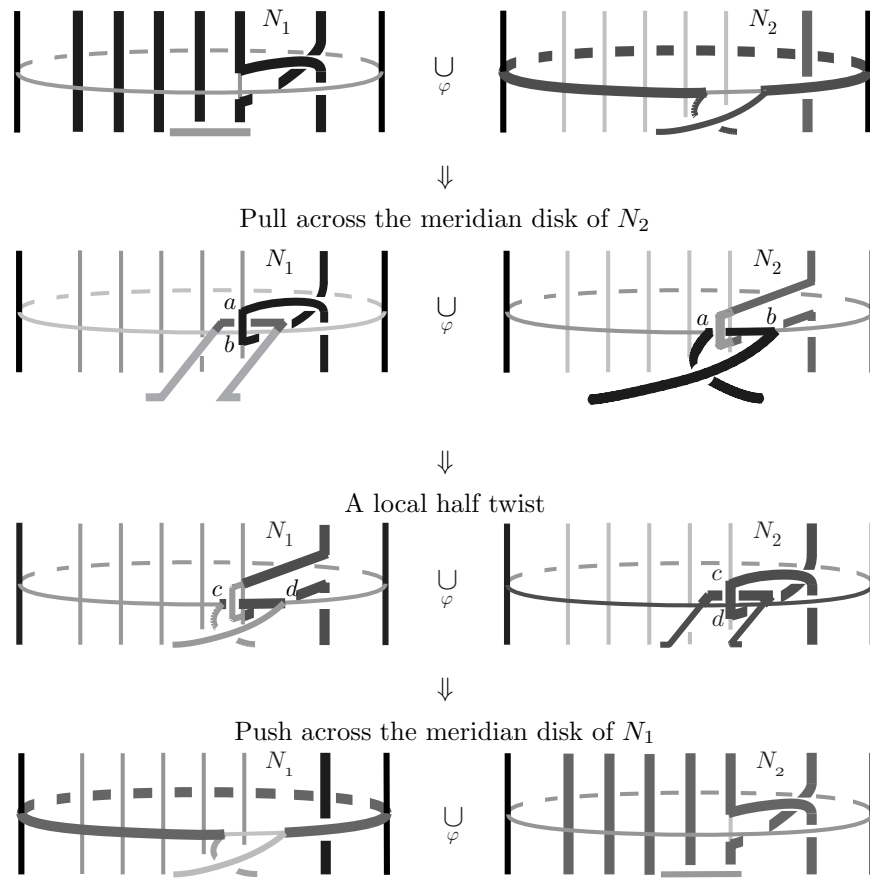

FIGURE 5. Local pictures of the 3-step isotopy from $\beta_1 \sqcup c_2$ to $c_1 \sqcup \beta_2$

Choose $\mathcal{N}(\beta_i)$ to be a disc bundle over β_i embedded into N_i so that each disc fiber $\subset * \times D^2$ (for $* \in S^1$) and has diameter $< 1/(p + 1)^2$. Moreover we may assume that $N(\beta_i)$ misses the core c_i .

The isotopy provided by Lemma 3 that sends $\beta_1 \sqcup c_2$ to $c_1 \sqcup \beta_2$ can be adjusted to send $\mathcal{N}(\beta_1) \sqcup N_2$ to $N_1 \sqcup \mathcal{N}(\beta_2)$, and to be “linear” and “disc-fiber preserving” on $\mathcal{N}(\beta_1) \sqcup N_2$. Then extend it to a diffeomorphism $f : M \rightarrow M$ which sends $\overline{N_1 - N(\beta_1)}$ to $\overline{N_2 - N(\beta_2)}$.

Now the $(p + 1)$ -adic solenoids $S_1 = \bigcap_{h=1}^\infty f^{-h}(N_1)$ and $S_2 = \bigcap_{h=1}^\infty f^h(N_2)$ are the repeller and the attractor of f , respectively. Moreover for each $x \notin S_1 \cup S_2$, $f^n(x)$ approaches to S_2 as n approaches to infinity, hence $\Omega(f) = S_1 \cup S_2$.

We have finished the proof of the Claim, therefore the IF part of Theorem 2. \square

Remark. By repeating the operations in the proof, we see that in the IF part of Theorem 2, the $\Omega(f)$ can be chosen to be two explicit $(mp + 1)$ -adic solenoids, $mp + 1 \neq 0, \pm 1$.

Proof of the IF part of Theorem 1. Suppose $M = N \# L(p, q)$. It is easy to see that the isotopy above that sends $\beta_1 \sqcup c_2$ to $c_1 \sqcup \beta_2$ can be adjusted to send N_2

to $\mathcal{N}(\beta_2)$, to be “linear” and “disc-fiber preserving” on N_2 , and to be the identity on a 3-ball B^3 in N_1 . Therefore there is a diffeomorphism on the $L(p, q) - \text{int}B^3$ which has a knotted solenoid as a hyperbolic attractor and is the identity on its 2-sphere boundary. Such a diffeomorphism can be extended to M by the identity on the punctured N .

We have proved the IF part of Theorem 1.

5. PROOF OF COROLLARY 1

We start from the end of the proof of the IF part of Theorem 2.

Since $\Omega(f)$ consists of two Smale solenoids S_1 and S_2 , $\Omega(f)$ meets Axiom A.

To prove the corollary, we need the following explicit description of stable and unstable manifolds of $\Omega(f)$.

First, S_1 is the union of stable manifolds of points in S_1 , and S_2 is the union of unstable manifolds of points in S_2 . Moreover, since $f^{-1}|_{N_1}$ (resp. $f|_{N_2}$) preserves the disc fibers of N_1 (resp. N_2), $\mathbb{F}_1 = \bigcup f^n(S^1 \times D_1)$ (resp. $\mathbb{F}_2 = \bigcup f^{-n}(S^1 \times D_2)$) provides an R^2 -foliation of $L(p, q) - S_2$ (resp. R^2 -foliation of $L(p, q) - S_1$), which is the union of unstable manifolds of points in S_1 (resp. the union of stable manifolds of points in S_2). Hence we have

$$W^s(S_1) = S_1, \quad W^u(S_1) = \mathbb{F}_1, \quad W^u(S_2) = S_2, \quad W^s(S_2) = \mathbb{F}_2.$$

Therefore

$$W^s(S_1) \cap W^u(S_2) = \emptyset, \quad W^s(S_2) \cap W^u(S_1) \neq \emptyset.$$

It is clear that f meets the no cycle condition. Hence f is Ω -stable by (b) of the Stability Theorem.

This f is not structurally stable by the Stability Theorem (a) and the following Lemma 4.

Lemma 4. \mathbb{F}_1 and \mathbb{F}_2 do not meet transversely.

Proof. We need only to prove that $\mathbb{F}_1|$ and $\mathbb{F}_2|$, the restrictions of \mathbb{F}_1 and \mathbb{F}_2 on $\overline{N_1 - N(\beta_1)}$ respectively, do not meet transversely.

Note that $\overline{N_1 - N(\beta_1)}$ has two different $(p+1)$ -punctured disc bundle structures provided by $\mathbb{F}_1|$ and $\mathbb{F}_2|$. (An n -punctured disc is obtained from the 2-sphere by removing the interior of $n+1$ disjoint sub-discs.) More directly, one $(p+1)$ -punctured disc bundle structure is induced from the pair $(N_1, N(\beta_1))$ and the other is induced from the pair $(\overline{N_1 - N(\beta_1)} \cup N_2, N_2) = (f^{-1}(N_2), f^{-1}(N(\beta_2))) \cong (N_2, N(\beta_2))$.

It is easy to see that the restrictions of two fibrations $\mathbb{F}_1|$ and $\mathbb{F}_2|$ on $\overline{N_1 - N(\beta_1)}$ meet transversely on $\partial\overline{N_1 - N(\beta_1)}$.

Let F_1 be a fiber of $\mathbb{F}_1|$, which is a $(p+1)$ -punctured disc. Suppose $\mathbb{F}_1|$ and $\mathbb{F}_2|$ meet transversely on $\overline{N_1 - N(\beta_1)}$. Then the intersections of F_1 and $\mathbb{F}_2|$ provide a codimension one foliation on F_1 which meets ∂F_1 transversely. Now the genus $(p+1)$ closed surface $D(F_1)$, the double of F_1 , will admit a codimension one foliation, which is impossible since $|p+1| > 1$. \square

We have completed the proof of Corollary 1.

ACKNOWLEDGMENT

We would like to thank the referee for his suggestions which enhanced the paper. We also thank Professors H. Duan, S. Gan and L. Wen for helpful conversations.

REFERENCES

- [EK] J. Eells, Jr., and N.H. Kuiper, *Manifolds which are like projective planes*, IHS Publ. Math. **14**(1962), 5–46. MR **26**:3075
- [F] J. M. Franks, *Knots, links and symbolic dynamics*, Ann. of Math. **113**(1981), 529–552. MR **83h**:58074
- [Ha] S. Hayashi, *Hyperbolicity, stability, and creation of homoclinic points*, Proceedings of the International Congress of Mathematicians, vol. II (Berlin, 1998). Doc. Math. 1998, Extra vol. II, 789–796 (electronic). MR **99f**:58115
- [He] J. Hempel, *3-manifolds*, Ann. of Math. Studies vol. 86, Princeton University Press, 1976. MR **54**:3702
- [Ni] Z. Nitecki, *Differentiable dynamics, An introduction to the orbit structure of diffeomorphisms*, MIT Press, 1971. MR **58**:31210
- [Pe] Y. B. Pesin, *Dimension theory in dynamical systems, Contemporary views and applications*, University of Chicago Press, 1997. MR **99b**:58003
- [Po] H. L. Porteous, *Anosov diffeomorphisms of flat manifolds*, Topology **11**(1972), 307–315. MR **45**:6035
- [R] G. Reeb, *Sur certaines propriétés topologiques des variétés feuilletées*, Publ. Inst. Math. Univ. Strasbourg **11**, pp. 5–89, 155–156. Actualités Sci. Ind., no. 1183, Hermann & Cie., 1952. MR **14**:1113a
- [S] S. Smale, *Differentiable dynamical systems*, Bull. AMS **73**(1967), 747–817. MR **37**:3598
- [Su] M. C. Sullivan, *Visually building Smale flows in S^3* , Topology Appl. **106**(2000), 1–19. MR **2001g**:37025
- [T] E. S. Thomas, Jr., *One-dimensional minimal sets*, Topology **12**(1973), 233–242. MR **48**:5123
- [W] R. F. Williams, *One-dimensional non-wandering sets*, Topology **6**(1967), 473–487. MR **36**:897

DEPARTMENT OF MATHEMATICS, PEKING UNIVERSITY, BEIJING 100871, PEOPLE'S REPUBLIC OF CHINA

E-mail address: jiangbj@math.pku.edu.cn

DEPARTMENT OF MATHEMATICS, PEKING UNIVERSITY, BEIJING 100871, PEOPLE'S REPUBLIC OF CHINA

Current address: Department of Mathematics, Princeton University, Princeton, New Jersey 08544

E-mail address: yni@princeton.edu

DEPARTMENT OF MATHEMATICS, PEKING UNIVERSITY, BEIJING 100871, PEOPLE'S REPUBLIC OF CHINA

E-mail address: wangsc@math.pku.edu.cn